

OPTOMIX

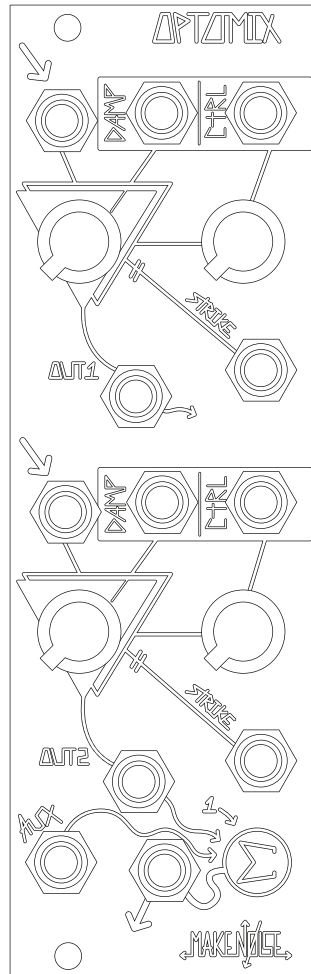

← MAKE NOISE →

TABLE OF CONTENTS

- LIMITED WARRANTY
- INSTALLATION
- PANEL CONTROLS
- OVERVIEW
- GETTING STARTED
- TIPS AND TRICKS
- PATCH IDEAS



LIMITED WARRANTY

Make Noise warrants this product to be free of defects in materials or construction for a period of one year from the date of purchase (proof of purchase/invoice required).

Malfunction resulting from wrong power supply voltages, backwards or reversed eurorack bus board cable connection, abuse of the product, removing knobs, changing faceplates, or any other causes determined by Make Noise to be the fault of the user are not covered by this warranty, and normal service rates will apply.

During the warranty period, any defective products will be repaired or replaced, at the option of Make Noise, on a return-to-Make Noise basis with the customer paying the transit cost to Make Noise.

Make Noise implies and accepts no responsibility for harm to person or apparatus caused through operation of this product.

Please contact technical@makenoisemusic.com with any questions, Return To Manufacturer Authorization, or any needs & comments.

<http://www.makenoisemusic.com>



About This Manual:

Written by Tony Rolando
Edited by Walker Farrell
Illustrated by W.Lee Coleman
Layout by Lewis Dahm



INSTALLATION

Electrocution hazard!

Always turn the Eurorack case off and unplug the power cord before plugging or unplugging any Eurorack bus board connection cable. Do not touch any electrical terminals when attaching any Eurorack bus board cable.

The Make Noise Optomix is an electronic music module requiring 25mA of +12VDC and 25mA of -12VDC regulated voltage and a properly formatted distribution receptacle to operate. It must be properly installed into a Eurorack format modular synthesizer system case.

Go to <http://www.makenoisemusic.com/> for examples of Eurorack Systems and Cases.

To install, find 8HP in your Eurorack synthesizer case, confirm proper installation of Eurorack bus board connector cable on backside of module (see picture below), plug the bus board connector cable into the Eurorack style bus board, minding the polarity so that the RED stripe on the cable is oriented to the NEGATIVE 12 Volt line on both the module and the bus board. On the Make Noise 6U or 3U Busboard, the negative 12 Volt line is indicated by the white stripe.

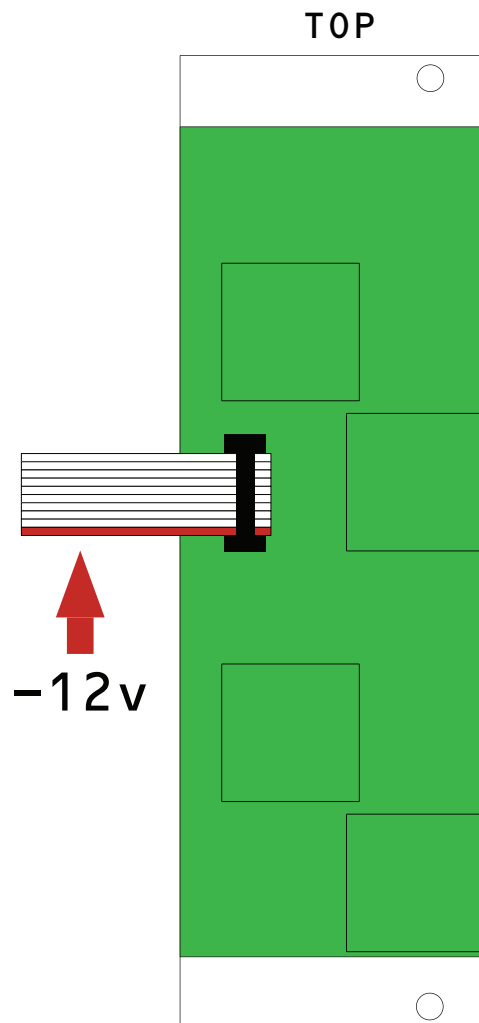

Please refer to your case manufacturer's specification for location of the negative supply.



PANEL CONTROLS

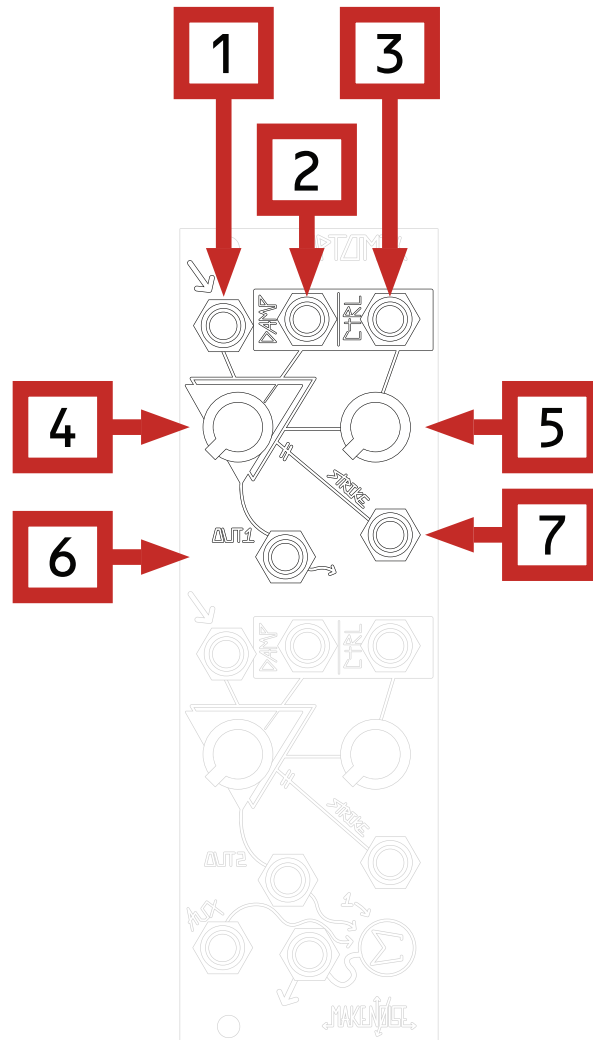

1. **CHannel 1 Signal Input:** Direct-coupled signal input capable of accepting audio or control signals. Range of up to 10Vpp.
2. **CHannel 1 DAMP CV Input:** CV input for the CHannel's DAMPing parameter, now capable of accepting audio or control signals. Normalized to +8V so that with nothing patched, the CHannel 1 DAMP Combo Pot operates as a manual control for the parameter. Range 0V-8V.
3. **CHannel 1 CONTROL Input:** Direct coupled, highly-sensitive CV input for the CHannel's vactrol VCA. Normalized to +8V so that with nothing patched, the Channel 1 CONTROL Combo Pot operates as a level control for the Offset. Range 0V-8V.
4. **CHannel 1 DAMP Combo Pot:** Unipolar attenuator for DAMP CV Input. With nothing patched to the DAMP CV Input, operates as a manual control for the DAMP parameter.
5. **CHannel 1 Combo Pot:** Unipolar attenuator for CONTROL Signal Input. With nothing patched to the CHannel 1 Control Signal Input, operates as a level control for the Offset.
6. **CHannel 1 Signal OUT:** Output of the signal applied to the CHannel 2 input, as processed by the LPG. 10Vpp (depending upon settings and source material).
7. **CHannel 1 STRIKE Input:** Gate Input for striking or plucking the vactrol. Expects 8V Gate.



PANEL CONTROLS

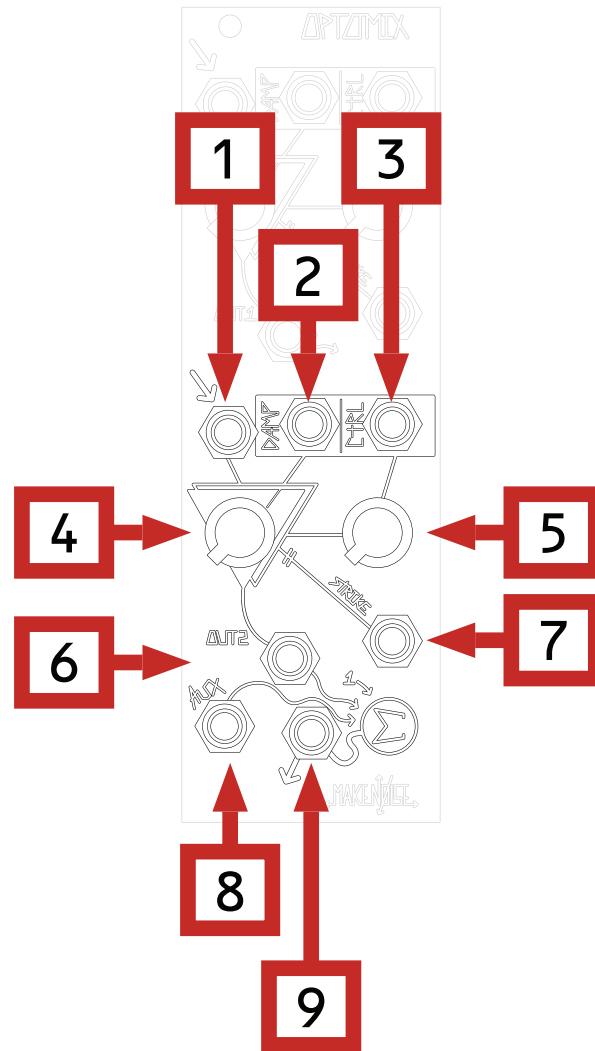

1. **CHannel 2 Signal INput:** Direct-coupled signal input capable of accepting audio or control signals. Range of up to 10Vpp.
2. **CHannel 2 Control Signal INput:** Direct-coupled, highly-sensitive CV input for CHannel 2's vactrol VCA. Normalized to +8V so that with nothing patched, the Channel 2 CONTROL Combo Pot operates as a level control for the Offset. Range 0V-8V.
3. **CHannel 2 DAMP CV INput:** INput for CHannel 2's DAMP parameter, now capable of receiving audio or control signals. Normalized to +8V so that with nothing patched, the CHannel 2 DAMP Combo Pot operates as a manual control for the parameter. Range 0V-8V.
4. **CHAnnel 2 DAMPCombo Pot:** Unipolar attenuator for CHannel 2 DAMP CV INput. With nothing patched to the CHannel 2 DAMP CV INput, operates as a manual control for the parameter.
5. **CHAnnel 2 CONTROL Combo Pot:** Unipolar attenuator for CHannel 2 CONTROL Signal INput. With nothing patched to the CHannel 2 Control Signal INput, operates as a level control for the Offset.
6. **CHAnnel 2 Signal OUTput:** Direct-coupled OUTput of the Signal applied to the CHannel 2 INput, as processed by the LPG. 10Vpp (depending upon gate settings and source material).
7. **CHAnnel 2 STRIKE INput:** Gate INput for striking or plucking the CHannel 2 CONTROL vactrol. Expects 8V Gate.
8. **AUXiliary INput:** Direct-coupled signal input to the SUM circuit, allowing for the chaining of multiple Optomix and modDemix units to create larger mixes. Capable of accepting audio or control signals up to 10Vpp.
9. **SUM OUT:** The SUM or mix of all signals processed by the OPTOMIX is output at this jack. 10Vpp



OVERVIEW

OPTOMIX is a two-channel Low Pass Gate that utilizes 4 vactrols in order to provide simultaneous voltage-control over the Amplitude and Frequency content of a signal. It is in essence, a VCF-A (Voltage OPTOMIX SUMming stage, complete with an AUXiliary INput allowing for the chaining of multiple units to create larger mixes (this also works well in combination with the modDemix).

The new OPTOMIX has the same sound and original feature set, save for one Normalization: CHannel 1 Signal OUTput is no longer Normalled to the CHannel 2 Signal INput. What we have added is the ability to allow OPTOMIX to be used as an Audio Compressor or CV Processor/Generator.

The DAMP parameter, unique to OPTOMIX, allows the artist to ProGraM the way the Low Pass Gate responds to a decaying control transient, such as an Envelope signal generated by MATHS or a Gate applied to a CHannel's STRIKE INput (see below). DAMP is continuously-variable, allowing anything from a long, slow, ringing to a short, fast, and muted response.

The STRIKE INput allows the artist to use a typical 8V Gate signal to trigger the LPG (Low Pass Gate) circuit by "plucking" or "striking" the vactrol, thus allowing it to impart its magically-slow response time to the Amplitude of the signal being processed (this concept is also featured on the Make Noise DPO, MMG, LxD, and RxMx). Combined with the DAMP parameter, STRIKE allows for the programming of percussive sounds (i.e. sharp Attack with Voltage-Controlled Decay) without the need for a Voltage-Controlled Envelope Generator.

As a VCA, OPTOMIX has a moderate Attack response and slow Decay response, meaning that it turns on sound that is dynamically processed. Folks have often described the sound as "ringing," and while the circuit is not technically ringing, that does describe many of the sounds possible when using a LPG such as the OPTOMIX in order to process complex signals generated through FM or Ring Modulation.

As a VCF, it is a mild, non-resonant Low Pass circuit acting to gently reveal (or hide) the sharper edges of a simultaneous loss in high frequency content that is similar to the natural loss of energy in idio and membranophonic instruments.

PERSPECTIVE

OPTOMIX, being a vactrol-based circuit, will never have the speed or tight tolerances found in many other VCA and VCF circuits. I would recommend that musicians desiring closely matched gain across multiple channels of VCAs look elsewhere! If you seek to ProGraM extremely short sounds, clicks, pops and ticks, OPTOMIX is not the best choice. What OPTOMIX smooth, natural sounding circuit.



GETTING STARTED

It's a VCA, It's a VCF...

The Low Pass Gate operates simultaneously in the Amplitude and Frequency domains. As a CONTROL Signal becomes more positive, the Amplitude of the processed signal increases with the lower frequencies being more quickly amplified than the higher frequencies. As a CONTROL Signal become less positive, the Amplitude decreases with the higher frequencies being attenuated much sooner than the lower frequencies. The net effect is that fast, transient Amplitude Modulation of a signal's lower frequencies are more pronounced, lurking in the spectrum, while higher frequencies are eagerly diminished. Manual manipulation of the Panel Controls does not display this phenomenon well. A fast, short Envelope of around +8V, when patched to a CONTROL INput, provide a beautiful example of OPTOMIX's ability to produce acoustic-like Attack & Decay transients. The processed signal appears to ring- not unlike a struck drum, piano string, or xylophone bar.

The DAMP CV may lessen this ringing, not unlike applying your hand to the head of a drum while striking it, or muting a guitar string with your palm while plucking it. Increasing the DAMP parameter could be likened to applying greater pressure, or further muting, until finally, there is almost no ringing at all. In the past, it has been common practice to patch the output of a Low Pass Gate to a VCA in order to control the RINGING effect, while reducing or even eliminating the signal-bleed often associated with vactrol-based Low Pass Gates. The OPTOMIX's DAMP circuit allows for this control without the use of an additional VCA In order to control the ringing effect of a CHannel, adjust the associated CHannel's DAMP Combo Pot, or apply a CONTROL signal to its DAMP INput and adjust the DAMP Combo Pot for Attenuation. In order to reduce the signal bleed (when the Gate is closed), add a touch of DAMPing.

CV Processing and Envelope Generation

A Normalization of a positive Offset has been added to each CHannel's Signal INputs, which allows for level-shifting of CV, Envelope Generation, and even subtle, non-symmetrical clipping of signals. To use the new OPTOMIX for Envelope Generation, patch a Gate Signal to a CHannel's STRIKE INput and patch the associated CHannel OUTput to a modulation input of your choosing (e.g. the CV INput of a VCA). That's it. In a pinch, OPTOMIX may be used to generate an Offset, attenuate a Signal, and SUM a Signal with an Offset. This sort of Voltage MATH is what makes modular synthesis so much fun! Just be sure to set OPTOMIX's unused CHannel's CONTROL Combo Pot Full CCW in order to avoid any unwanted Offsets. An OPTOMIX CHannel may also be used as a simple Slew Limiter, with "FALL" time set by the associated CHannel's DAMP (Note: "RISE" time would be short and unable to be modified).

Sidechain Compression

A revised version of the DAMP circuit allows for Audio-rate signals to be used as Control Voltages. As a result, modulating a CHannel's DAMP parameter relative to its CONTROL parameter now causes Gain Reduction, with the Compression Ratio set by its CONTROL parameter. For the best results, the CONTROL Combo Pot should be set to around 50%.



TIPS AND TRICKS

The DAMP CV INput may act as an ACCENT parameter when utilizing the OPTOMIX in a sequencing patch. For example, patch your non-ACCENTed Envelope signal to a CHannel's CONTROL INput with the associated CONTROL Combo Pot set to about 70% for attenuation. Then apply an ACCENT GATE/signal to the STRIKE INput. Steps where the ACCENT Gate STRIKEs/is "high" will be LOUDER.

Now, let's add some DAMPING to the above patch on the ACCENTed Steps by MULTing that same ACCENT Gate to the DAMP CV IN and setting the associated DAMP Combo Pot to taste (set to at least 20%). Next, set up a Dynamic FM patch using OPTOMIX to control the DO's FM INDEX. Rather than applying an Envelope to the CONTROL input, just patch a Gate to the STRIKE INput and set the DAMP Combo Pot to taste. This is great for bursts of modulation and works with any mod source (e.g. LFO, Ran-dom, Noise, etc.) In order to emulate a palm-mute, apply your Gate signal to both a STRIKE INput on the OPTOMIX and MATHS CHannel 1/4's TRIGGER INput. Set MATHS RISE Panel Control to have a long RISE time (i.e. at least 60%) with a short FALL time (less than 50%). Finally, patch the associated MATHS CHannel's Unity OUTput to the OPTOMIX's DAMP CV INput with the associated DAMP Combo Pot set to at least 65%.

Side-Chain

Patch an Audio-rate signal to a CHannel's SIGNAL INput. The DAMP INput acts as the Side Chain Input with the associated DAMP COMBO Pot setting the Threshold. The CONTROL Combo Pot determines the Ratio, with the best settings typically falling somewhere between 40% and 60%. The resulting sound is soft and squishy- especially useful for creating ducking effects.

For instance, try using OPTOMIX CHannel 1 in order to generate a Kick Drum sound, patching the CHannel 1 OUTput to the CHannel 2 DAMP INput. Now, patch a drone to the CHannel 2 Signal Input and monitor the SUM OUTput. Finally, adjust the CHannel 2 DAMP and CONTROL Combo Pots to taste.



PATCH IDEAS

The New Bongo

Set up a VCO for Two-Operator FM by applying a SINE wave to its Linear FM input and patching the resulting waveform to OPTOMIX's CHannel 1 Signal INput. Patch PRESSURE POINTS Common Gate OUTput to the OPTOMIX's CHannel1 STRIKE INput and PRESSURE POINTS CHannel 3 GATE OUTput to the OPTOMIX's CHannel 1 DAMP INput. Strike the "Bongo" by [TAPPING] PP Touchplate 4 and "dampen" the bongo during or after striking it by [TAPPING] PP Touchplate 3. Use the DAMP Combo Pot to set the amount of DAMPening.

FM Pings

Patch an FM source such as an audio-rate SINE wave to OPTOMIX CHannel1 Signal INput. Patch the CHAnnel1 OUTput to the Linear FM INput on STO or another VCO of your choice. Adjust OPTOMIX CONTROL Combo Pot full CCW (0%). Patch a Trigger or Gate source to OPTOMIX CHannel1 STRIKE INput to "ping" the destination VCO with a short burst of FM. Adjust the DAMP Combo Pot to taste.

