

Tangrams

Dual Analog ADSR/VCA with Cycling Gate Pulsers

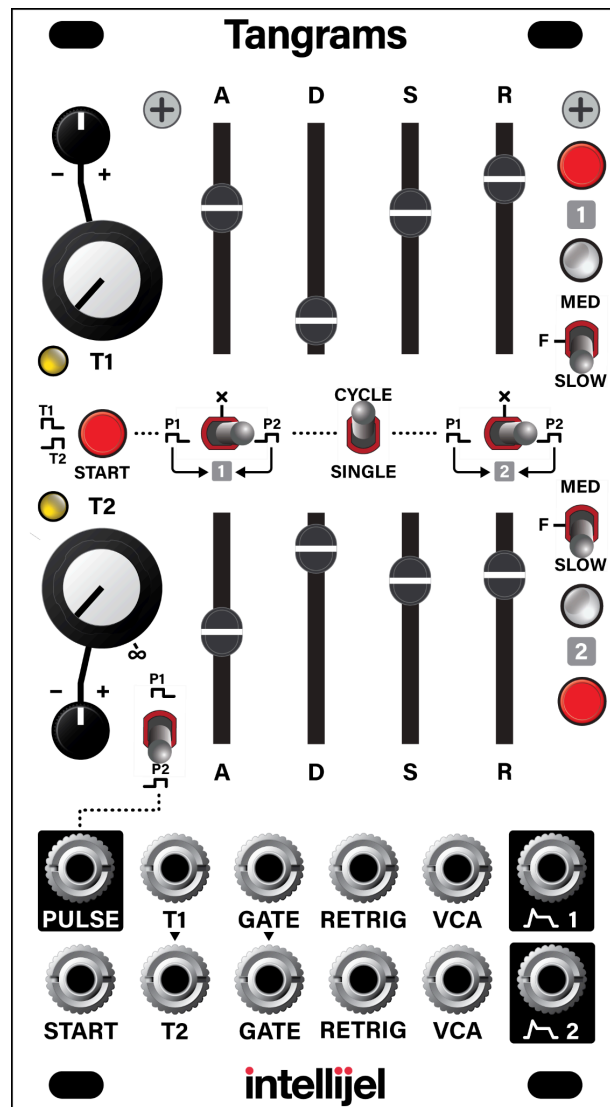

TABLE OF CONTENTS

COMPLIANCE	3
INSTALLATION	4
Installing Your Module	5
OVERVIEW	6
ENVELOPE 1	7
Envelope 1 Controls	7
Envelope 1 Jacks	9
ENVELOPE 2	10
PULSER	11
Pulser Controls	12
Pulser Jacks	16
Pulser / Envelope Interaction	17
SINGLE-SHOT Pulse / Envelope Examples	18
CYCLING Pulse Examples	22
TECHNICAL SPECIFICATIONS	27



COMPLIANCE



This device complies with Part 15 of the FCC Rules. Operation is subject to the following two conditions: (1) this device may not cause harmful interference, and (2) this device must accept any interference received, including interference that may cause undesired operation.

Changes or modifications not expressly approved by Intellijel Designs, Inc. could void the user's authority to operate the equipment.

Any digital equipment has been tested and found to comply with the limits for a Class A digital device, pursuant to part 15 of the FCC Rules. These limits are designed to provide reasonable protection against harmful interference when the equipment is operated in a commercial environment. This equipment generates, uses, and can radiate radio frequency energy and, if not installed and used in accordance with the instruction manual, may cause harmful interference to radio communications.



This device meets the requirements of the following standards and directives:

EMC: 2014/30/EU

EN55032:2015 ; EN55103-2:2009 (EN55024) ; EN61000-3-2 ; EN61000-3-3

Low Voltage: 2014/35/EU

EN 60065:2002+A1:2006+A11:2008+A2:2010+A12:2011

RoHS2: 2011/65/EU

WEEE: 2012/19/EU

INSTALLATION

Intellijel Eurorack modules are designed to be used with a Eurorack-compatible case and power supply. We recommend you use Intellijel cases and power supplies.

Before installing a new module in your case, make sure your power supply has a free power header and sufficient available capacity to power the module:

- Sum up the specified +12V current draw for all modules, including the new one. Do the same for the -12 V and +5V current draw. The current draw will be specified in the manufacturer's technical specifications for each module.
- Compare each of the sums to specifications for your case's power supply.
- Only proceed with installation if none of the values exceeds the power supply's specifications. Otherwise you must remove modules to free up capacity or upgrade your power supply.

You will also need to ensure your case has enough free space (hp) to fit the new module. To prevent screws or other debris from falling into the case and shorting any electrical contacts, do not leave gaps between adjacent modules, and cover all unused areas with blank panels. Similarly, do not use open frames or any other enclosure that exposes the backside of any module or the power distribution board.

You can use a tool like [ModularGrid](#) to assist in your planning. Failure to adequately power your modules may result in damage to your modules or power supply. If you are unsure, please [contact us](#) before proceeding.

Installing Your Module

When installing or removing a module, always turn off the power to the case and disconnect the power cable. Failure to do so may result in serious injury or equipment damage.

Ensure the 10-pin connector on the power cable is connected correctly to the module before proceeding. The red stripe on the cable must line up with the -12V pins on the module's power connector. The pins are indicated with the label -12V, a white stripe next to the connector, the words "red stripe", or some combination of those indicators. Some modules have shrouded headers to prevent accidental reversal.

Most modules will come with the cable already connected, but it's good to double check the orientation. Be aware that some modules may have headers that serve other purposes, so ensure the cable is connected to the correct one.

The other end of the cable, with a 16-pin connector, connects to the power bus board of your Eurorack case. Ensure the red stripe on the cable lines up with the -12V pins on the bus board. On Intellijel power supplies the pins are labeled with "-12V" and/or a thick white stripe, while others have shrouded headers to prevent accidental reversal.

If you're using another manufacturer's power supply, check their documentation for instructions.

Before reconnecting power and turning on your modular system, double check that the ribbon cable is fully seated on both ends and that all the pins are correctly aligned. If the pins are misaligned in any direction or the ribbon is backwards you can cause damage to your module, power supply, or other modules.

After you have confirmed all the connections, you can reconnect the power cable and turn on your modular system. You should immediately check that all your modules have powered on and are functioning correctly. If you notice any anomalies, turn your system off right away and check your cabling again for mistakes.

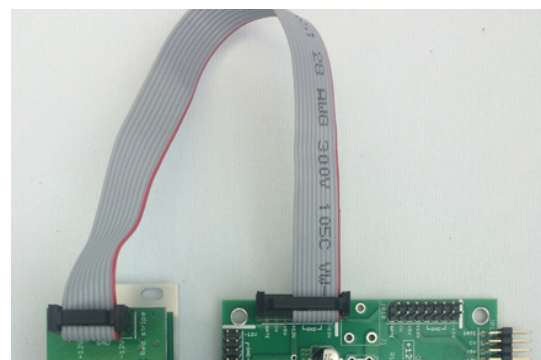
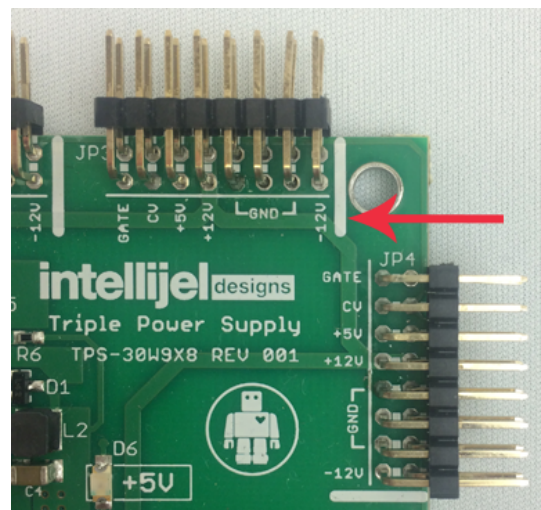
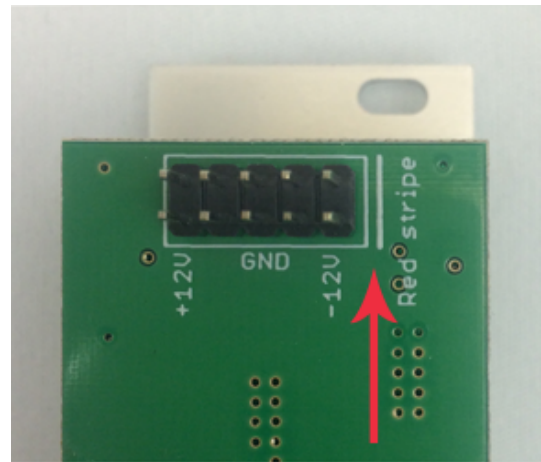

OVERVIEW

Tangrams is a dual ADSR with a heart... or, in this case, a pulser. It is, perhaps, best understood by mentally dividing its panel into three sections, as shown here:

- ENVELOPE 1 (RED section)** : The first of two traditional ADSR (Attack, Decay, Sustain, Release) envelope generators. The Attack, Decay and Release times all scale with a 3-position SPEED switch, enabling everything from fast, snappy envelopes (suitable for percussion) to slow, lethargic envelopes (ideal for pads and drones). The envelope can be gated with its MANUAL GATE button, a GATE IN signal, or the internal PULSER (see below). You can retrigger a currently gated envelope using its RETRIG input and, because the envelope output runs through a dedicated VCA, you can control its overall LEVEL via CV.
- ENVELOPE 2 (BLUE section)** : The second of two traditional ADSR (Attack, Decay, Sustain, Release) envelope generators. It is functionally identical to Envelope 1.
- PULSER (GREEN section)** : The PULSER section generates two sequential pulses (PULSE 1 and PULSE 2) — each with its own independent and CV-able control for setting the pulse length (labeled T1 and T2). PULSE 2 is always triggered at the conclusion of PULSE 1.

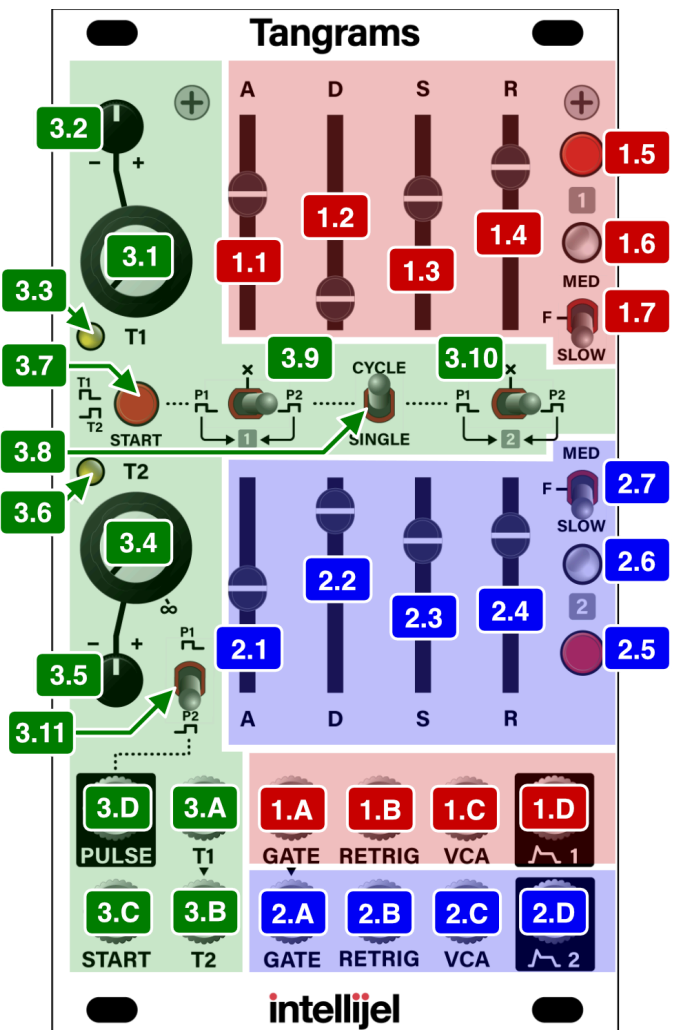

Each envelope lets you select whether or not you want to use the PULSER as an additional GATE source and, if you do, whether PULSE 1 or PULSE 2 is the HIGH (gate) PULSE. Sending the PULSER to an envelope will OR its gate with the envelope's GATE IN and MANUAL GATE button.

An additional switch lets you set whether PULSE 1 or PULSE 2 generates a HIGH gate via the PULSE OUT jack.



ENVELOPE 1

Envelope 1 Controls

[1.1] A (Attack Time) slider - Sets the time required for Envelope 1 to rise from zero (0V) to its maximum level (8V, unless scaled via the **LEVEL IN [1.C]** jack). The higher the slider, the slower the attack. The slider's overall time range depends on the setting of the **ENV 1 SPEED [1.7]** switch.

[1.2] D (Decay) time slider - Sets the time required for Envelope 1 to decrease from its maximum value to a level set by the **ENV 1 S (Sustain) [1.3]** slider. The higher the DECAY slider, the slower the decay time. The slider's time range depends on the setting of the **ENV 1 SPEED [1.7]** switch.

[1.3] S (Sustain) level slider - Sets the sustain level for Envelope 1, which is the level at which the envelope sustains while the *gating envelope* remains high. The higher the slider, the higher the sustain level. At the bottom, there is no sustain (0V). At the top, the sustain level is at the maximum (8V, unless scaled via the **LEVEL IN [1.C]** jack).

[1.4] R (Release) time slider - Sets the duration of Envelope 1's release stage. This is the time it takes the envelope to return to 0V once the *ENVELOPE GATE* voltage goes low. The higher the slider, the longer the release time. The slider's overall range depends on the setting of the **ENV 1 SPEED [1.7]** switch.

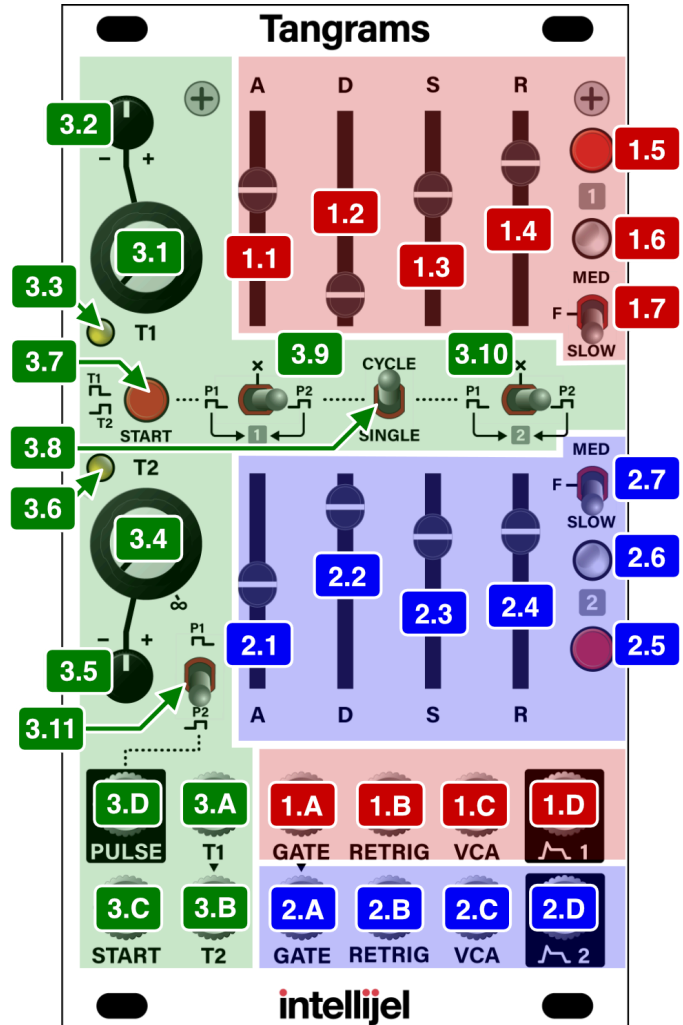

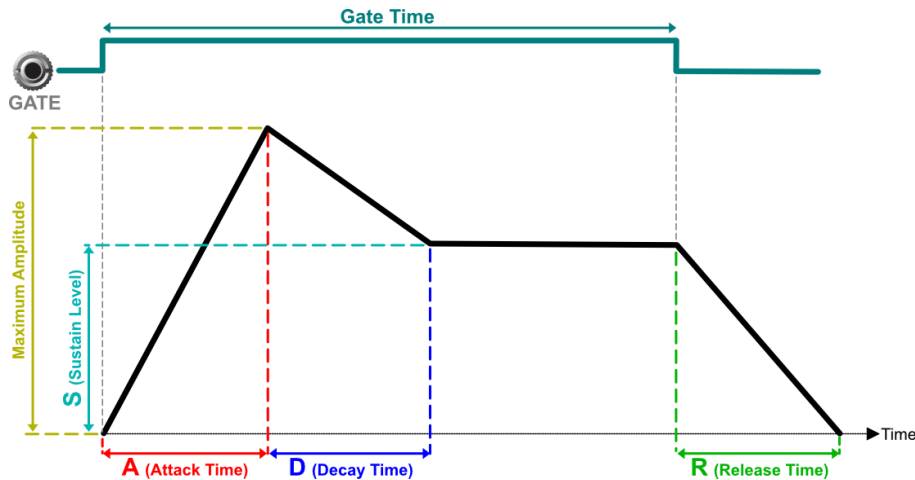

- [1.5] ENV 1 MANUAL GATE button** - Press this button to gate the envelope (just as if you had patched a gate signal into the **ENV 1 GATE IN [1.A]** jack. As long as the button is held down, the gate is high (+5V), as indicated by the **ENV 1 LEVEL Indicator [1.6]** LED.

IMPORTANT : The envelope's **MANUAL GATE** is OR'd with the **GATE IN [1.A]** signal, meaning the envelope is gated if either is high. It will also be OR'd with the **PULSER** when you set the **ENV 1 PULSE SOURCE [3.9]** switch to something other than the middle "X" position. The [PULSER controls](#) are discussed fully, later in this manual.

- [1.6] ENV 1 LEVEL indicator** - The brightness of this LED varies with the level of Envelope 1. The brighter the LED, the higher the envelope's amplitude.
- [1.7] ENV 1 SPEED switch** - Selects the overall scaling of the Envelope 1 times, with LOW speeds at the bottom, HI speeds in the middle, and MED speeds on top. Specifically:

- **F(AST)** Fastest overall envelope, good for percussive sounds.
Approximate maximum times are:
A : ~1.5 to 2.0 s
D/R : ~4 to 5 s
- **MED** Medium speed envelope, good for most sound design duties.
Approximate maximum times are:
A : ~10 to 12 s
D/R : ~22 to 24 s
- **SLOW** Long, slow envelope good for pads, drones, and evolving sounds.
Approximate maximum times are:
A : ~20 to 27 s
D/R : ~45 to 50 s

Envelope 1 Jacks

[1.A] ENV 1 GATE IN - The gate signal patched into this jack is used to gate Envelope 1. It is also normalled to Envelope 2. Specifically, if the GATE IN is high, the envelope moves through its ATTACK and DECAY stages until it hits the SUSTAIN stage, where it remains until the gate goes low — triggering the RELEASE stage. If the gate goes low before the sustain stage is reached, then the release stage begins immediately (without the envelope completing its earlier stages).

IMPORTANT : The envelope's GATE IN signal is OR'd with the **MANUAL GATE [1.5]** button, meaning the envelope is gated if either is high. It will also be OR'd with the **PULSER** when you set the **ENV 1 PULSE SOURCE [3.9]** switch to something other than the middle "X" position. The [PULSER controls](#) are discussed fully, later in this manual.

[1.B] ENV 1 RETRIG IN - If the signal gating Envelope 1 is high, then a trigger patched into this jack resets the envelope, and re-starts the ATTACK stage. If the signal gating Envelope 1 is low, then no triggering occurs.

[1.C] ENV 1 LEVEL IN - A voltage patched into this jack controls the amplitude of an internal VCA, through which Envelope 1's output is routed. This is ideal for using a CV (such as one generated by note velocity) to control the overall envelope level. You can also patch audio into the jack, and the envelope will then control the audio's output volume, just as if you had used an external VCA.

NOTE: 8V is normalled to this jack by default. So if nothing is patched into it, then **ENV 1 OUT [1.D]** contains an envelope with a maximum level of 8V. Inputting values above or below 8V will increase/decrease the envelope's maximum value proportionally.

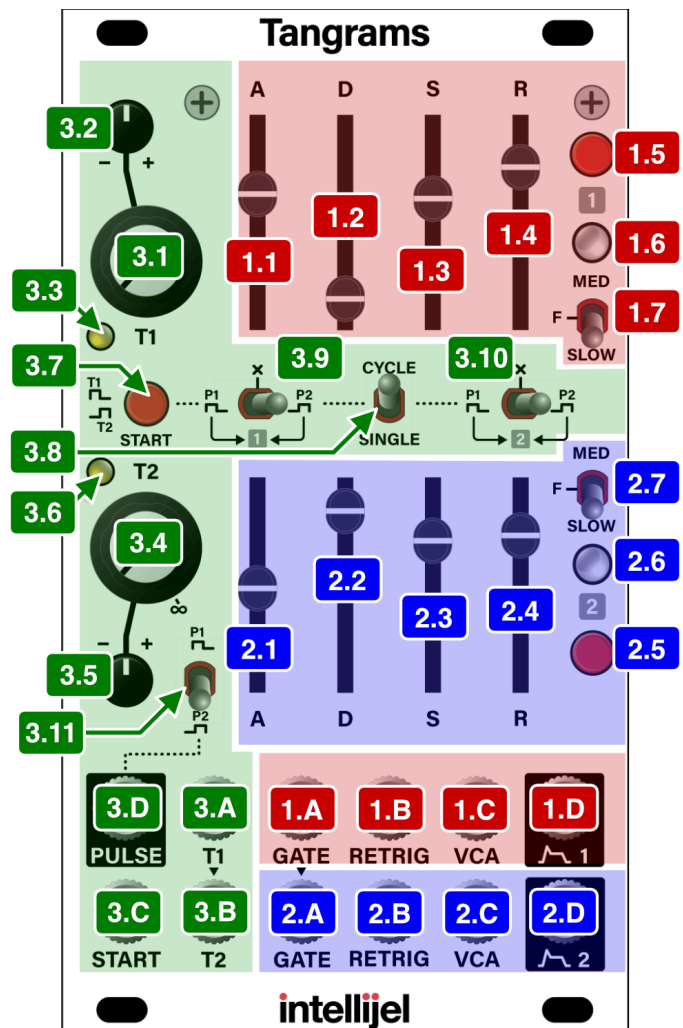

[1.D] ENV 1 OUT - The VCA'd output of Envelope 1. The actual envelope feeds into an internal VCA, whose level is controlled by **ENV 1 LEVEL IN [1.C]**, and the output of the VCA is sent to the ENV 1 OUT jack. Building a VCA into Tangrams has two benefits:

- It enables you to control the output's overall amplitude by patching CV into the LEVEL input, and even lets you invert the envelope by patching in negative voltage. A common CV input would be note velocity, since it would allow the overall envelope level to increase/decrease based on the input velocity.
- It enables full audio VCA functionality by patching audio into the LEVEL input, possibly eliminating the need to patch the output into a dedicated VCA.

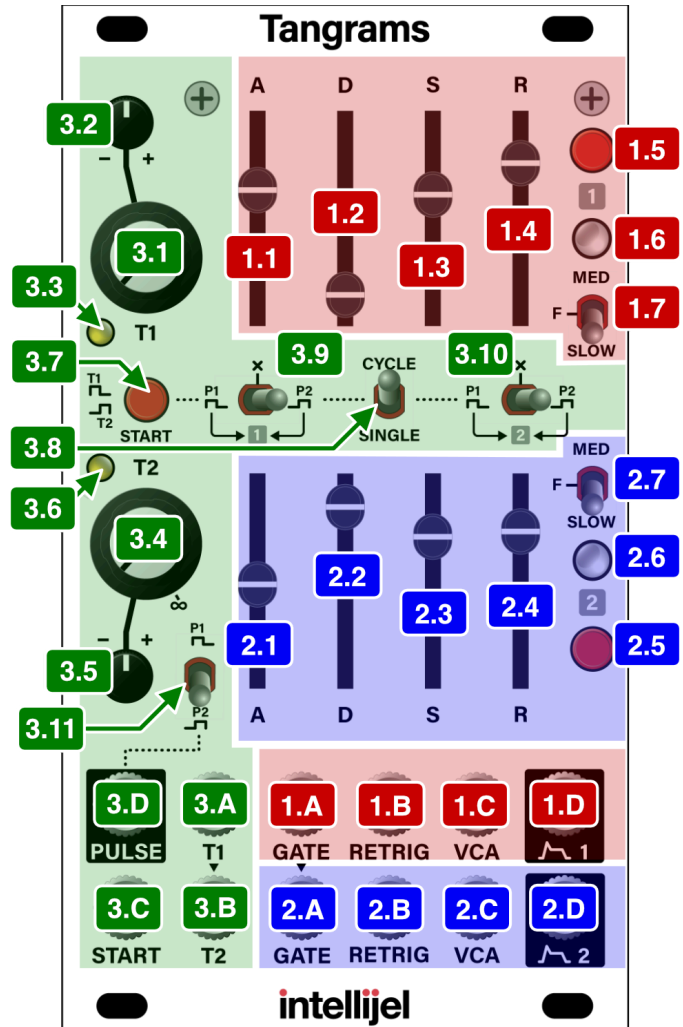

ENVELOPE 2

Envelope 2 is functionally identical, but completely separate from Envelope 1. As such, it has all the same inputs, outputs and parameter controls as Envelope 1.

Because of this, all the panel elements described for Envelope 1 apply to Envelope 2. So to learn about Envelope 2, simply read the Envelope 1 section, and replace any references to ENV 1 controls with the like-numbered ENV 2 controls.

PULSER

The PULSER generates two sequential pulses (PULSE 1 and PULSE 2) — each with its own independent Pulse Time setting (labeled T1 and T2). PULSE 2 is always triggered at the conclusion of PULSE 1. One pulse is always a high gate, and the other a low gate, with various switches determining which is which (as discussed below).

The PULSER can be used completely independent of the two envelopes (sending its output to the **PULSE OUT [3.D]** jack), or it can be used as an additional GATE source for the envelopes — OR'd with each envelope's own GATE inputs.

In **CYCLE** mode, the pulse sequence repeats endlessly, and runs automatically. In **SINGLE** mode, the pulse sequence plays once and stops, and is triggered either via the **START [3.7]** button or a signal patched into the **START [3.C]** jack. Once started, PULSE 1 lasts for a length of T1 [3.1] and is immediately followed by PULSE 2, which lasts for a length of T2 [3.2].

Each envelope has a **PULSE SELECT [3.9][3.10]** switch for selecting whether to use the PULSER as an additional envelope GATE source and, if so, whether PULSE 1 or PULSE 2 is the HIGH (gate) PULSE. Sending the PULSER to an envelope will OR its gate with the envelope's GATE IN and MANUAL GATE button.

An additional **PULSE POLARITY [3.11]** switch lets you set whether PULSE 1 or PULSE 2 generates a HIGH gate via the **PULSE OUT [3.D]** jack.

The function of each Pulser control & jack is discussed below, while the diagram shown in the [Pulser/Envelope Interaction](#) section offers a more graphical depiction of the relationship between the Pulser and the two Envelopes. Finally, numerous examples of how to use the Pulser are discussed in the [SINGLE-SHOT Pulse / Envelope Examples](#) and [CYCLING Pulse Examples](#) sections, later in this manual.

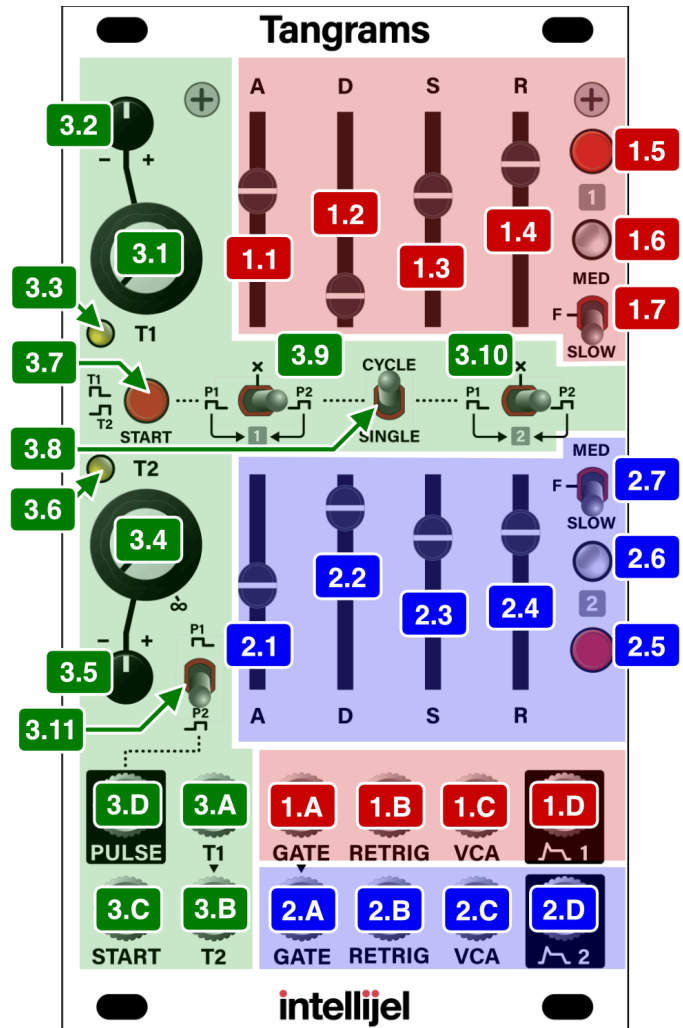

Pulser Controls

[3.1] T1 knob - T1 sets the length of PULSE 1, which ranges from 1ms (counterclockwise) to 16 sec (clockwise) with 2 sec at the “noon” position. You can modulate T1 via **T1 CV IN [3.A]** and its corresponding **T1 CV attenuverter [3.2]**.

When PULSE 1 ends, PULSE 2 (whose length is set by **T2 [3.4]**) follows it immediately.

The **CYCLE [3.8]** switch determines whether this pulse sequence plays a single time, or if it cycles repeatedly.

If the **CYCLE [3.8]** switch is set to **SINGLE**, then you must manually trigger the pulse sequence by either: 1) sending a trigger sent into the **START [3.C]** jack, or 2) pressing the the **START [3.7]** button. The Pulser will always run when in **CYCLE** mode.

The two **PULSE SELECT [3.9][3.10]** switches determine whether the PULSER is OR'd with an envelope's GATE source (and how); while the **PULSE OUT POLARITY [3.11]** switch sets whether PULSE 1 or PULSE 2 generates a HIGH gate via the **PULSE OUT [3.D]** jack.

See the [SINGLE-SHOT Pulse / Envelope Examples](#) and [CYCLING Pulse Examples](#) sections, later in this manual.

[3.2] T1 CV Attenuverter - Scales the amount (and polarity) of the voltage sent into the **T1 CV IN [3.A]** jack. The full range of the T1 control voltage is used when the knob is fully clockwise, and the voltage is attenuated as you rotate the knob counter-clockwise toward noon (straight up). At the noon (straight up) position, the incoming CV is fully attenuated, meaning it has no effect on T1. Turning the knob counterclockwise from the noon position inverts the incoming T1 control voltage (positive voltages become negative, and vice-versa), with the voltage level steadily increasing until the full (but inverted) range is reached when the knob is fully counter-clockwise.

[3.3] PULSE 1 INDICATOR LED - Lights when PULSE 1 is playing, and is off when it's not.

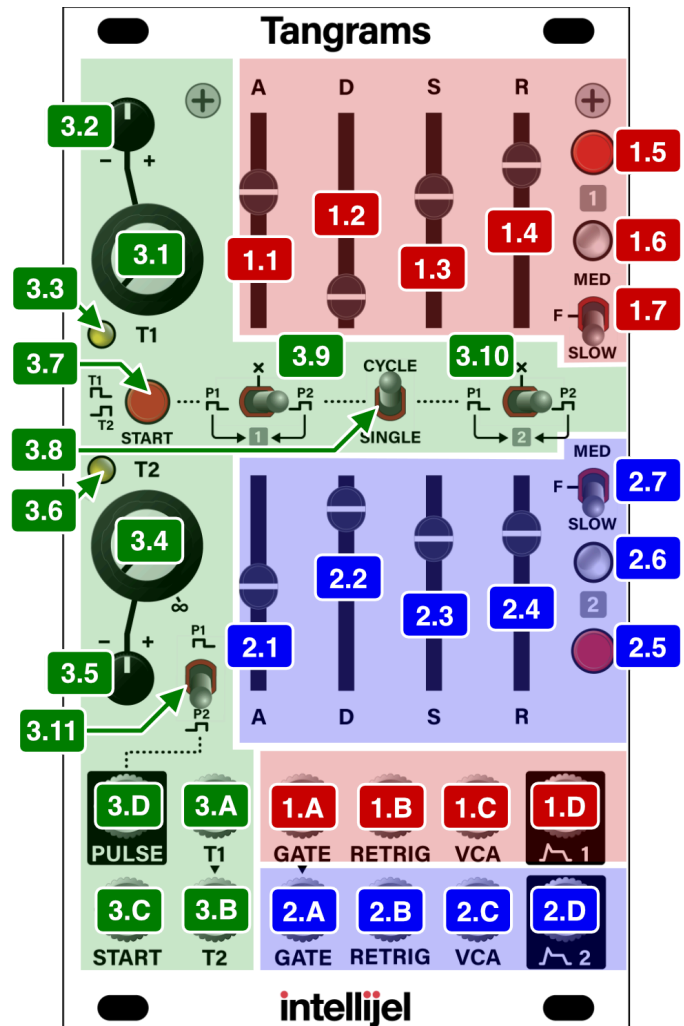

[3.4] T2 knob - T2 sets the length of PULSE 2.

In **SINGLE** mode, this ranges from 1ms (counterclockwise) to ∞ (clockwise) with 2 seconds at the “noon” position. In **CYCLE** mode, the maximum pulse length changes to 16 sec (clockwise). You can modulate T2 via the **T2 CV IN [3.B]** (or **T1 CV IN [3.A]** through normalled connection) and its corresponding **T2 CV attenuverter [3.5]**.

When PULSE 1 (whose length is set by **T1 [3.1]**) ends, PULSE 2 follows it immediately. The **CYCLE [3.8]** switch determines whether this PULSE 1 > PULSE 2 sequence plays a single time, or if it cycles repeatedly.

The two **PULSE SELECT [3.9][3.10]** switches determine whether the PULSER is OR'd with an envelope's GATE source (and how); while the **PULSE OUT POLARITY [3.11]** switch sets whether PULSE 1 or PULSE 2 generates a HIGH gate via the **PULSE OUT [3.D]** jack.

See the [SINGLE-SHOT Pulse / Envelope Examples](#) and [CYCLING Pulse Examples](#) sections, later in this manual.

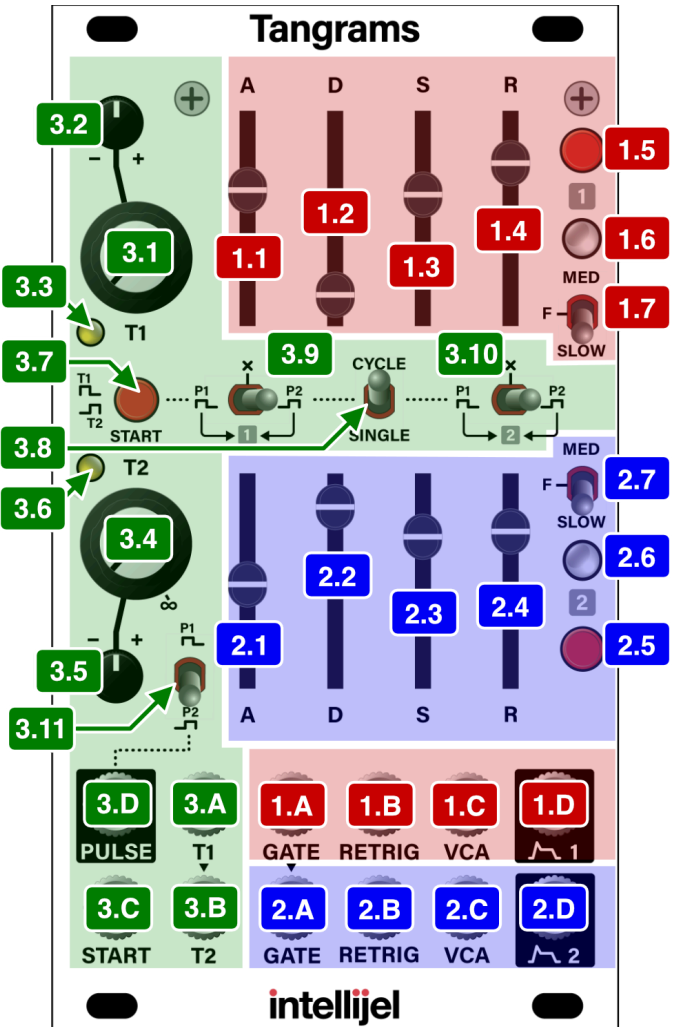

[3.5] T2 CV Attenuverter - Scales the amount (and polarity) of the voltage sent into the **T2 CV IN [3.B]** jack (or **T1 CV IN [3.A]** when normalled.) The full range of the T2 control voltage is used when the knob is fully clockwise, and the voltage is attenuated as you rotate the knob counter-clockwise toward noon (straight up). At the noon (straight up) position, the incoming CV is fully attenuated, meaning it has no effect on T2. Turning the knob counterclockwise from the noon position inverts the incoming T2 control voltage (positive voltages become negative, and vice-versa), with the voltage level steadily increasing until the full (but inverted) range is reached when the knob is fully counter-clockwise.

[3.6] PULSE 2 INDICATOR LED - Lights when PULSE 2 is playing, and is off when it's not.

[3.7] START Button - Press this button to start a stopped single-shot PULSER, or to reset a running PULSER to the beginning of PULSE 1. It's OR'd with the **START [3.C]** jack, which performs the same triggering function.



[3.8] CYCLE switch - Switches the Pulser between Single-shot and Cycle modes.

The Pulser generates two pulses, each with its own independent length (as set by **T1** and **T2**). PULSE 2 is always triggered at the conclusion of PULSE 1. Using the **CYCLE** switch, you can set whether a single pulse sequence is generated, or a cycling pulse sequence. Specifically:

- **DOWN ("SINGLE")** : If the **CYCLE** switch is down, the Pulser does not cycle, and a single pulse sequence (PULSE 1 > PULSE 2 > OFF) is triggered via the **START [3.C]** jack, or manually by the **START [3.7]** button. For more information, see [SINGLE-SHOT Pulse / Envelope Examples](#), later in this manual.
- **UP ("CYCLE")** : If the **CYCLE** switch is up, the Pulser will cycle repeatedly (PULSE 1 > PULSE 2 > PULSE 1 > PULSE 2 > etc.). For more information and examples, see [CYCLING Pulse Examples](#), later in this manual.

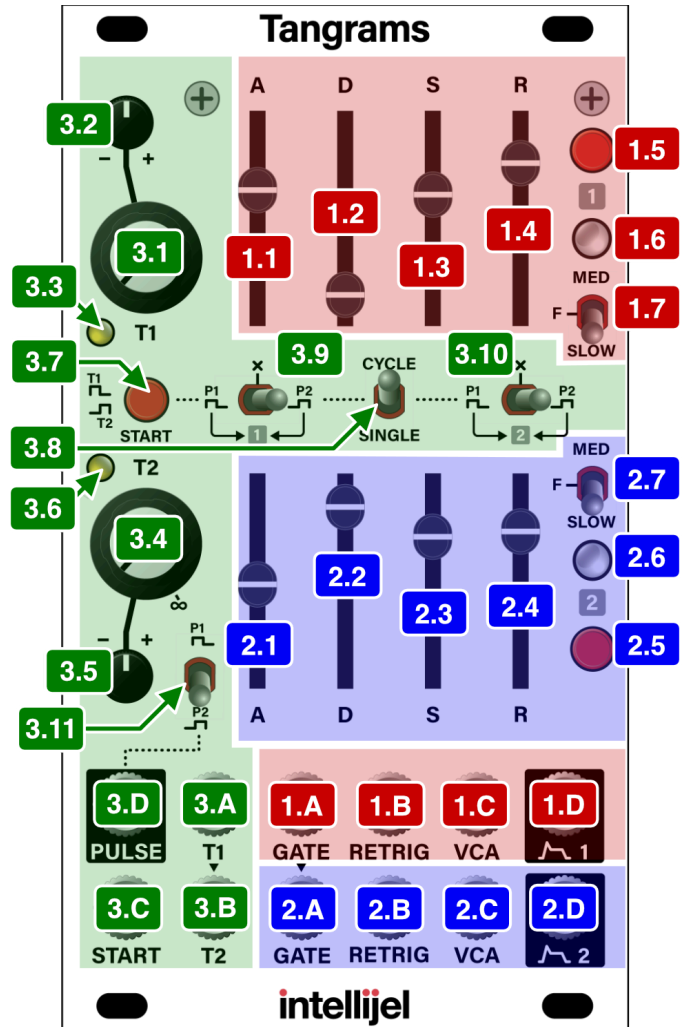

*NOTE: Turning on Cycling automatically starts the PULSER, without requiring a manual or external trigger, while turning off Cycling automatically stops it. However, once the PULSER is cycling, **START [3.C]** and/or the PULSER's **START [3.7]** will reset the cycle at the beginning of PULSE 1.*

[3.9] ENV 1 PULSE SOURCE switch - Sets the Pulse source for Envelope 1.

- LEFT (PULSE 1) : In this position, PULSE 1 generates the HIGH GATE, which lasts for the length of **T1 [3.1]**. It's OR'd with the **ENV 1 GATE IN [1.A]** jack and the **ENV 1 MANUAL GATE [1.5]** button.
- MID (PULSER = OFF): In this position, the PULSER is ignored by Envelope 1, and the envelope is gated only with its own GATE inputs.
- RIGHT (PULSE 2) : In this position, PULSE 2 generates a HIGH GATE, which lasts for the length of **T2 [3.4]**, and begins after the completion of PULSE 1. It's OR'd with the **ENV 1 GATE IN [1.A]** jack and the **ENV 1 MANUAL GATE [1.5]** button.

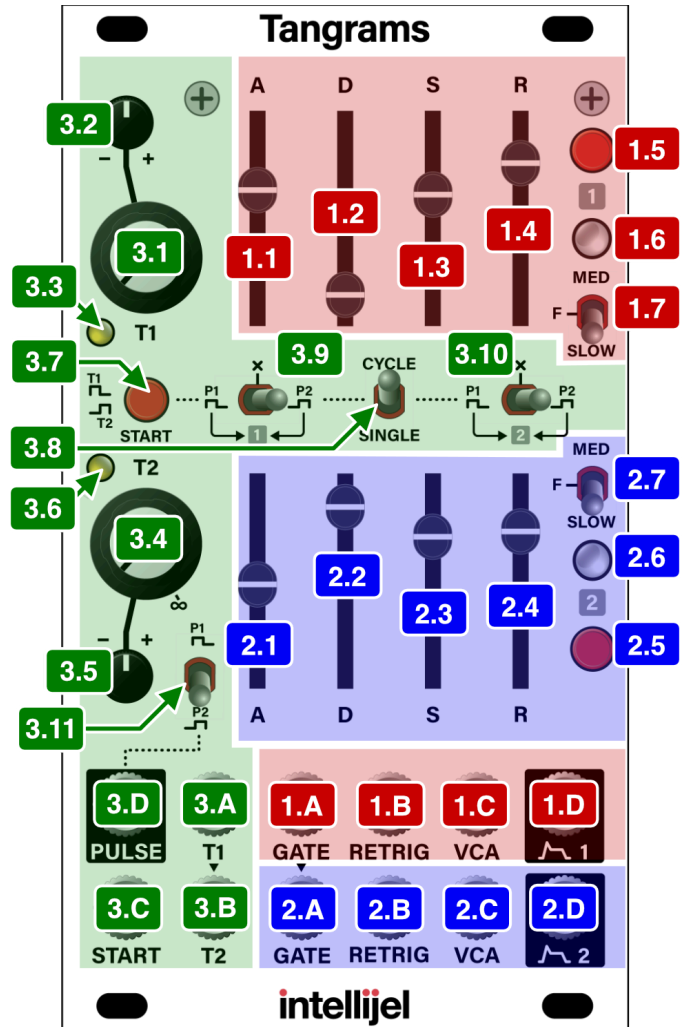

[3.10] ENV 2 PULSE SOURCE switch - Sets the Pulse source for Envelope 2.

- LEFT (PULSE 1) : In this position, PULSE 1 generates the HIGH GATE, which lasts for the length of **T1 [3.1]**. It's OR'd with the **ENV 2 GATE IN [2.A]** jack and the **ENV 2 MANUAL GATE [2.5]** button.
- MID (PULSER = OFF): In this position, the PULSER is ignored by Envelope 2, and the envelope is gated only with its own GATE inputs.
- RIGHT (PULSE 2) : In this position, PULSE 2 generates a HIGH GATE, which lasts for the length of **T2 [3.4]**, and begins after the completion of PULSE 1. It's OR'd with the **ENV 2 GATE IN [2.A]** jack and the **ENV 2 MANUAL GATE [2.5]** button.



[3.11] PULSE OUT POLARITY switch - This switch governs the polarity at the **PULSE OUT [3.D]** jack.

- **UP (PULSE 1 = HIGH)** : In this position, the **PULSE OUT [3.D]** voltage is HIGH for the duration of PULSE 1, and LOW for the duration of PULSE 2.
- **DOWN (PULSE 2 = HIGH)**: In this position, the **PULSE OUT [3.D]** voltage is LOW for the duration of PULSE 1, and HIGH for the duration of PULSE 2.

Pulser Jacks

[3.A] T1 CV IN - Patching voltage into this jack offsets the **T1** value from that set by the **T1 [3.1]** knob. Positive voltages increase PULSE 1 time, while negative voltages decrease it. The T1 CV IN voltage is attenuverted by the **T1 CV attenuverter [3.2]**, allowing you to scale and/or invert the incoming voltage. T1 CV IN also normals to **T2 CV IN [3.B]**.

[3.B] T2 CV IN - Patching voltage into this jack offsets the **T2** value from that set by the **T2 [3.4]** knob. Positive voltages increase PULSE 2 time, while negative voltages decrease it. The T2 CV IN voltage is attenuverted by the **T2 CV attenuverter [3.5]**, allowing you to scale and/or invert the incoming voltage. Note that it's possible to stall the pulser if the voltage increases T2 time to infinity.

[3.C] START IN - If the PULSER's **CYCLE [3.8]** switch is set to **SINGLE**, the PULSER is off unless 'started' with a trigger. Patching a trigger into this jack will start the PULSER (as will pressing the **START [3.7]** button). It will also restart the PULSER from the beginning of PULSE 1, if pressed prior to the completion of the pulse sequence.

If the PULSER's **CYCLE [3.8]** switch is set to **CYCLE**, then the PULSER starts automatically, without requiring an external trigger. However, when cycling, a trigger patched into **START** will restart the PULSER from the beginning of PULSE 1.

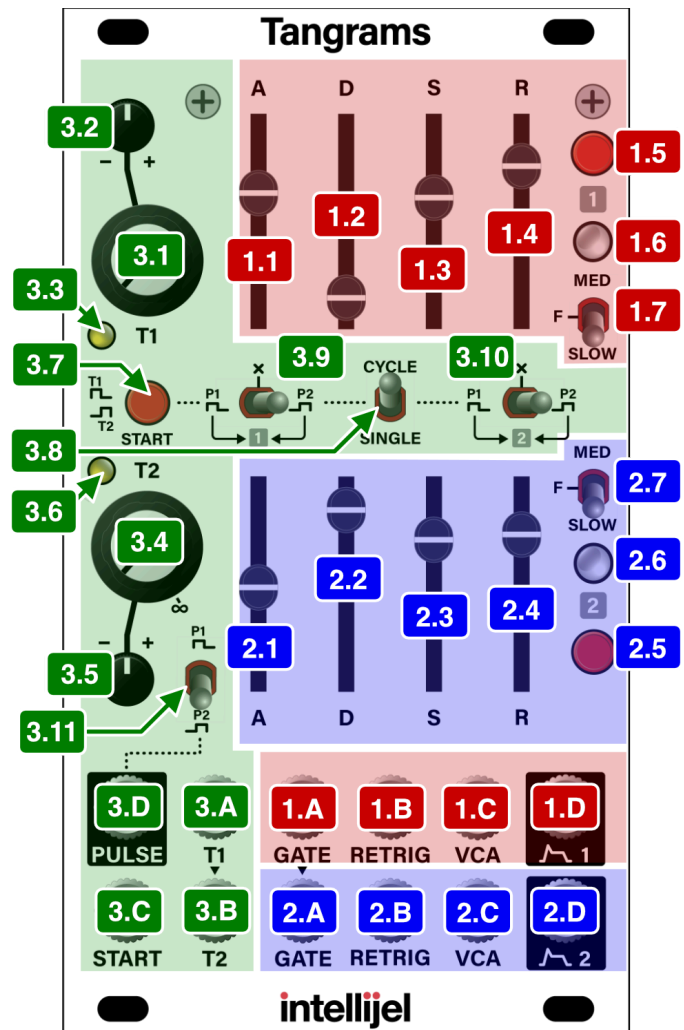

[3.D] PULSE OUT - This is the direct output of the PULSER. The polarity of the pulser is determined by the **PULSE OUT POLARITY [3.11]** switch.

Pulser / Envelope Interaction

This manual makes frequent use of the term “OR,” which is a type of logic operation that compares multiple inputs and says “as long as any one of the inputs is true, then the output is true.” Used in the context of Tangrams, it means “as long as any one envelope gate source is high, then the envelope is gated.” That is, if the MANUAL GATE button is high OR the GATE input is high OR the PULSE is high THEN the envelope is being gated.

The following flowchart indicates how envelope gates are determined (**black** connecting lines), and how state-change triggers (**magenta** connecting lines) affect those gates. **RED** blocks indicate Envelope 1; **BLUE** blocks indicate Envelope 2; and **GREEN** blocks indicate the PULSER.

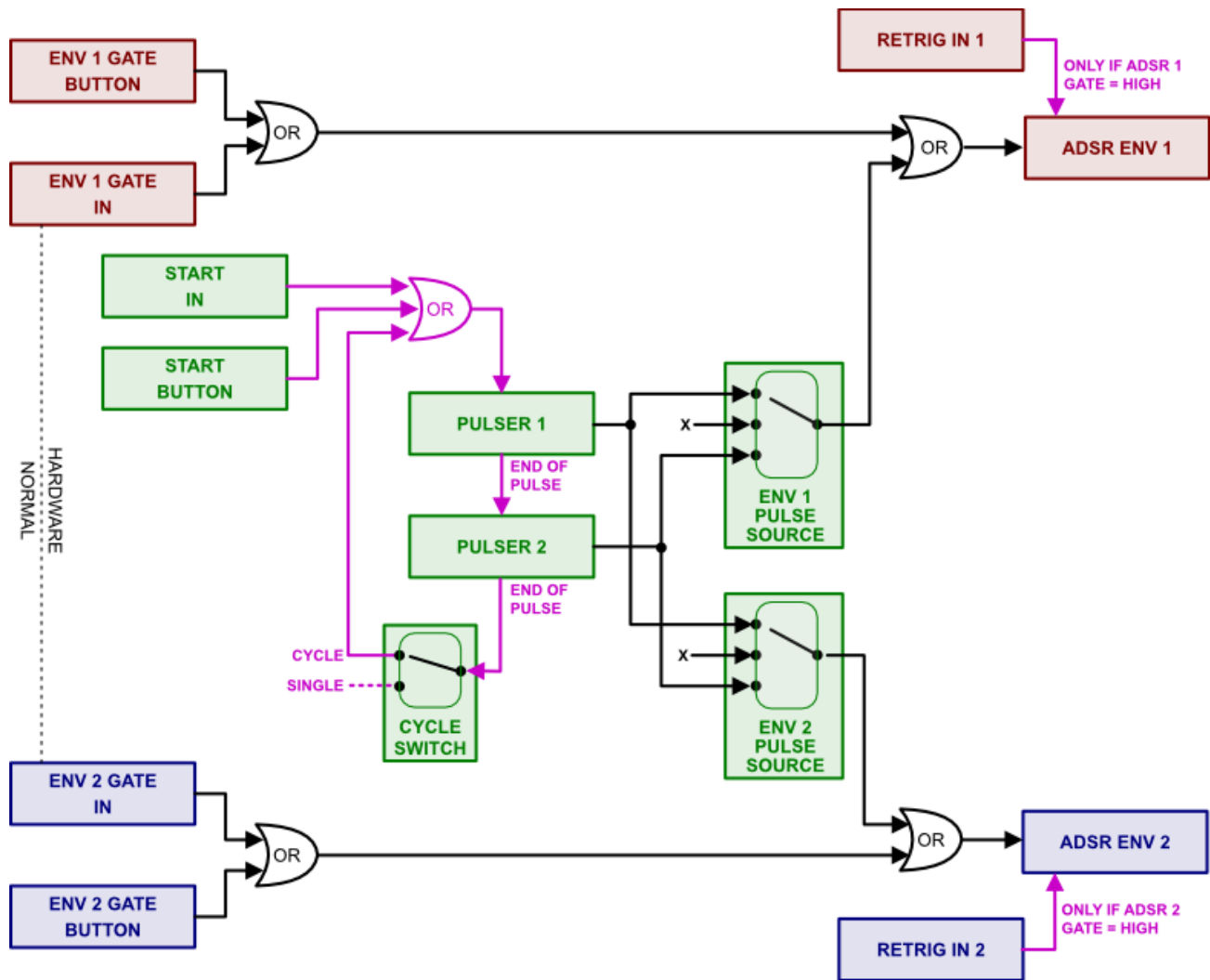

SINGLE-SHOT Pulse / Envelope Examples

The flowchart shown on the previous page is really all you need to figure out how the PULSER and the envelopes interact. However, to clarify further, below are several examples that show some possible interactions between a single-cycle, 1-shot pulse and an envelope.

EXAMPLE 1 : No Effect

The PULSER will have no effect on the envelope if an envelope's **PULSE SOURCE [3.9 or 3.10]** is set to the middle ("X") position.

It will also have no effect if the HIGH PULSE time is shorter than the envelope's GATE input.

In the example on the right:

- **CYCLE [3.8]** = SINGLE
- Envelope's **PULSE SOURCE [3.9 or 3.10]** = P1
- **GATE** and **START** triggered at the same time
- PULSE 1 is shorter than the GATE IN time

RESULT : The PULSER has no effect on the envelope since the GATE IN time is longer than the PULSE 1 time.

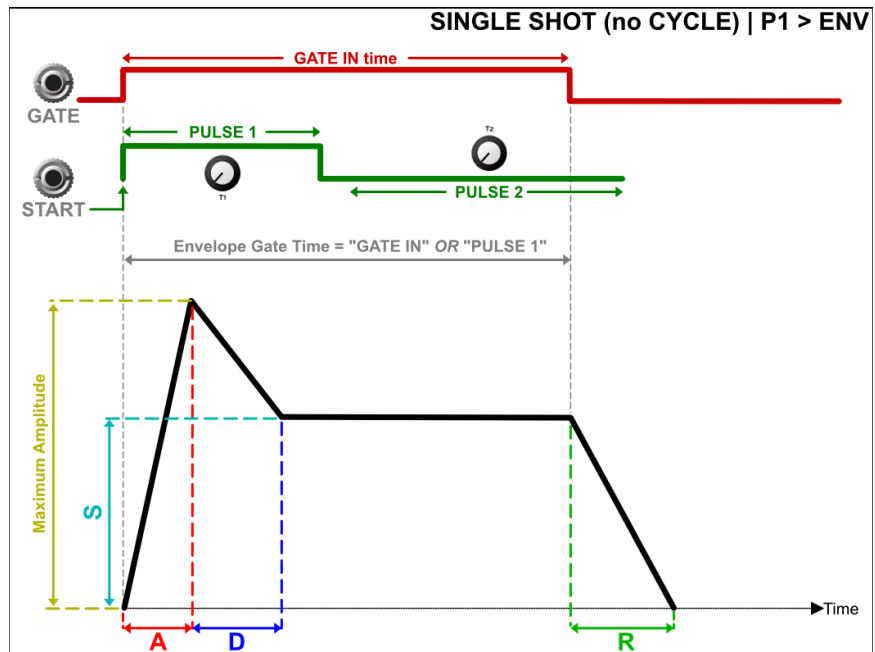

EXAMPLE 2 : GATE Extender (PULSE 1)

In this example, PULSE 1 is on for longer than the envelope's own GATE input, meaning it acts as a gate extender:

- **CYCLE [3.8]** = SINGLE
- Envelope's **PULSE SOURCE [3.9 or 3.10]** = P1
- **START** triggered after GATE (but it doesn't have to be in this example).
- PULSE 1 is longer than the GATE IN time

RESULT : Even though the Envelope's GATE IN goes low, the PULSE 1 remains HIGH, extending the envelope.

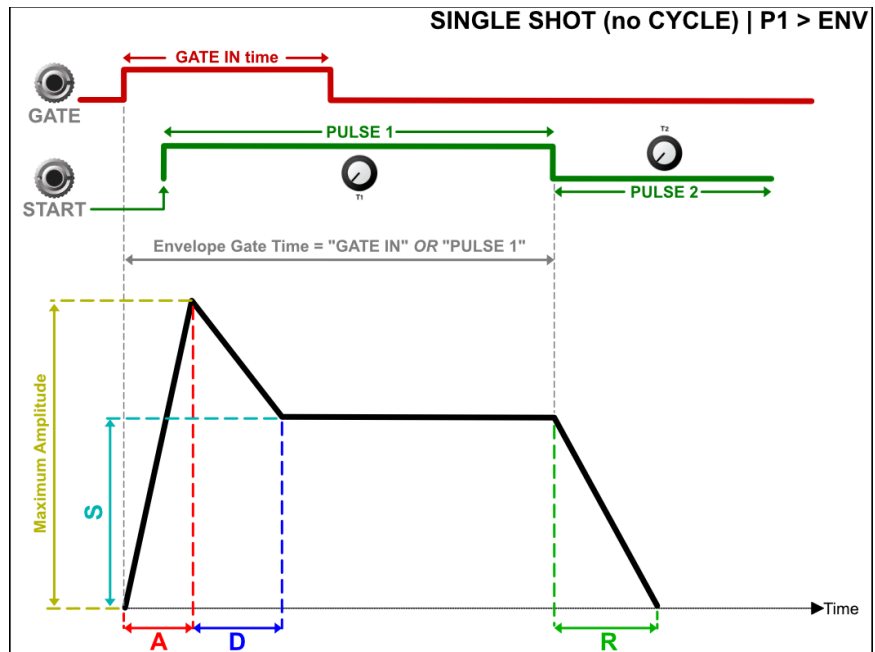

EXAMPLE 3 : TRIGGER to GATE Converter

In this example, the envelope's GATE input is not used. Instead, the envelope is gated entirely by PULSE 1, which is sent HIGH by a trigger patched into the START jack, and a GATE length determined by T1.

- **CYCLE [3.8]** = SINGLE
- Envelope's **PULSE SOURCE [3.9 or 3.10]** = P1
- **GATE** unused, **START** triggers envelope.
- T1 sets the GATE time.

RESULT : A trigger is used to GATE an envelope.

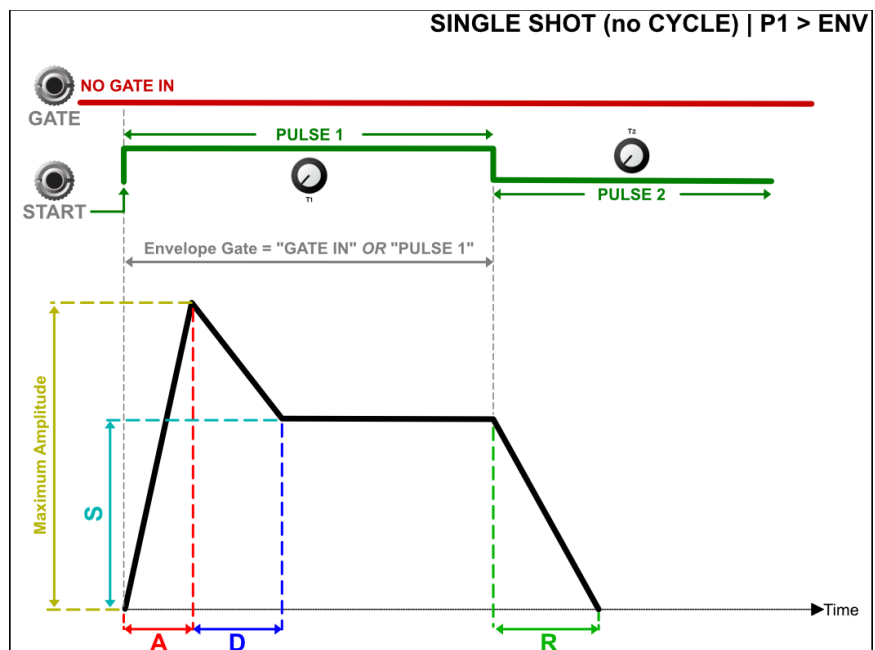

EXAMPLE 4 : GATE Extender (PULSE 2)

In this example, PULSE 2 goes HIGH before the GATE input goes LOW, and stays HIGH after the GATE input goes LOW, meaning PULSE 2 acts as a gate extender:

- **CYCLE [3.8]** = SINGLE
- Envelope's **PULSE SOURCE [3.9 or 3.10]** = P2
- PULSE 2 goes HIGH before **GATE IN** goes LOW.
- PULSE 2 stays HIGH after the **GATE IN** goes LOW.

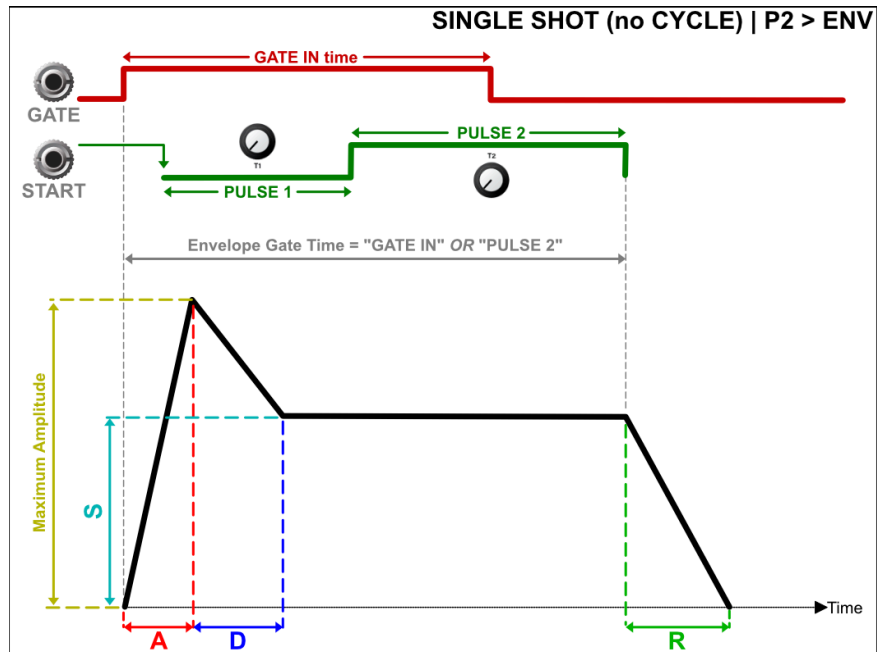

RESULT : Because PULSE 2 is OR'd with the envelope's GATE IN, the fact it's still HIGH when the GATE IN goes LOW means PULSE 2 extends the envelope's GATE time.

EXAMPLE 5 : Complex Envelope

In this example, PULSE 2 goes HIGH after the GATE input goes LOW — re-triggering and re-gating the envelope.

- **CYCLE [3.8]** = SINGLE
- Envelope's **PULSE SOURCE [3.9 or 3.10]** = P2
- PULSE 2 goes HIGH after the **GATE IN** goes LOW.

RESULT : Because PULSE 2 is OR'd with the envelope's GATE IN, it results in a re-triggering and re-gating of the envelope.

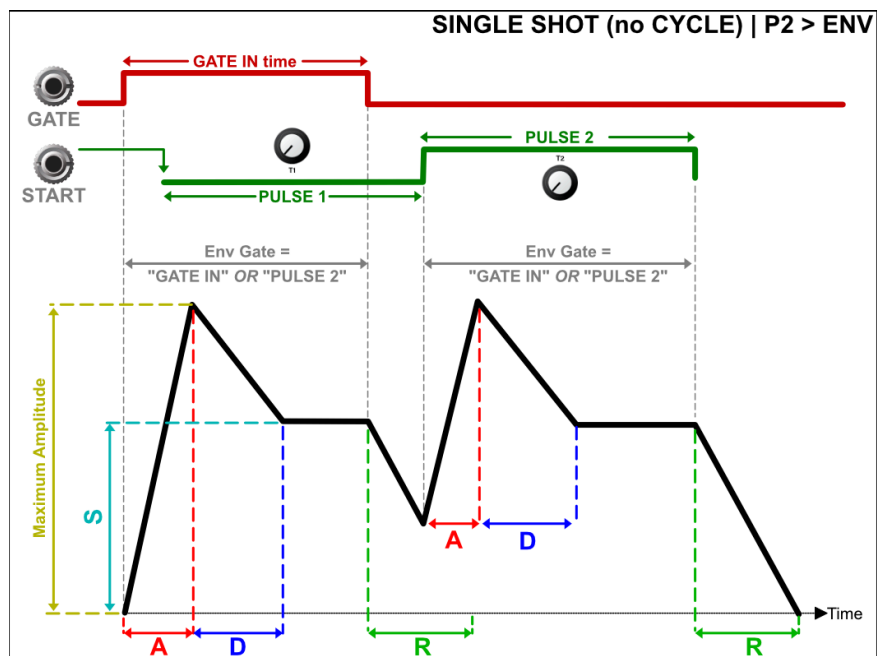

EXAMPLE 6 : Delayed Envelope

In this example, the envelope's GATE input is not used.

Instead, the envelope is gated entirely by PULSE 2, which goes HIGH only after PULSE 1 completes.

- **CYCLE [3.8] = SINGLE**
- Envelope's **PULSE SOURCE [3.9 or 3.10] = P2**
- PULSE 2 goes HIGH after PULSE 1 completes.

RESULT : *T1* determines how long the start of the envelope is delayed, while *T2* determines the GATE TIME for the envelope.

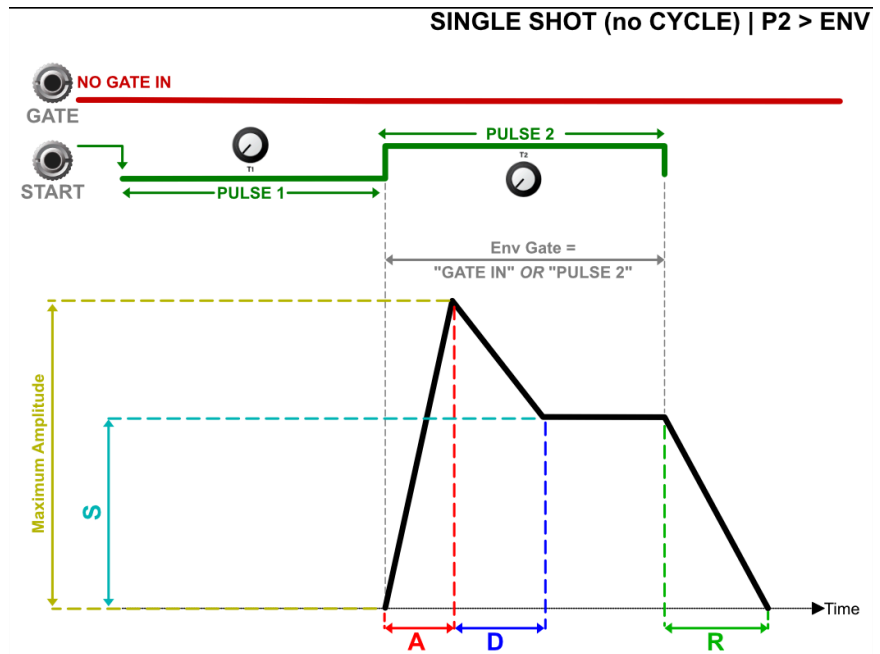

CYCLING Pulse Examples

The flowchart shown earlier in the [Pulser/Envelope Interaction](#) section is really all you need to figure out how the PULSER cycles and interacts with envelopes. However, to provide a bit of additional clarity plus some incentive, below are several CYCLING examples. All have the **CYCLE [3.8]** switch set to CYCLE (up), and none are using any of the envelope's own GATE or RETRIG inputs.

EXAMPLE 1 : In this first example, **ENV 1 PULSE SOURCE [3.9] = P1** ; PULSE 1 is longer than **A+D** ; PULSE 2 is shorter than **R**.

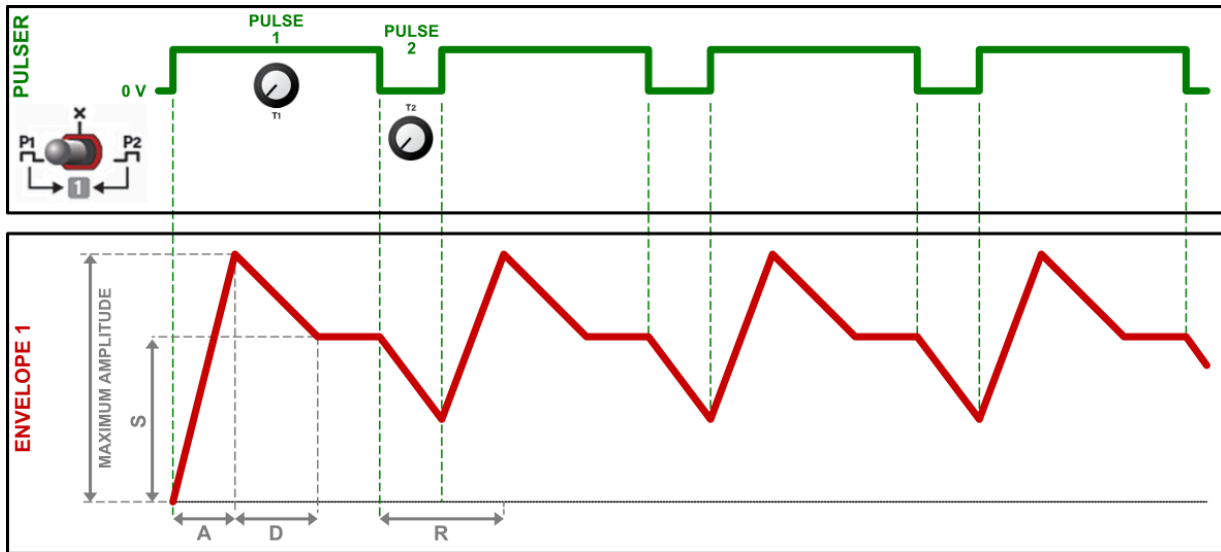

EXAMPLE 2 : In the following example, **ENV 1 PULSE SOURCE [3.9] = P1** ; PULSE 1 is longer than **A+D** ; PULSE 2 is longer than **R**.

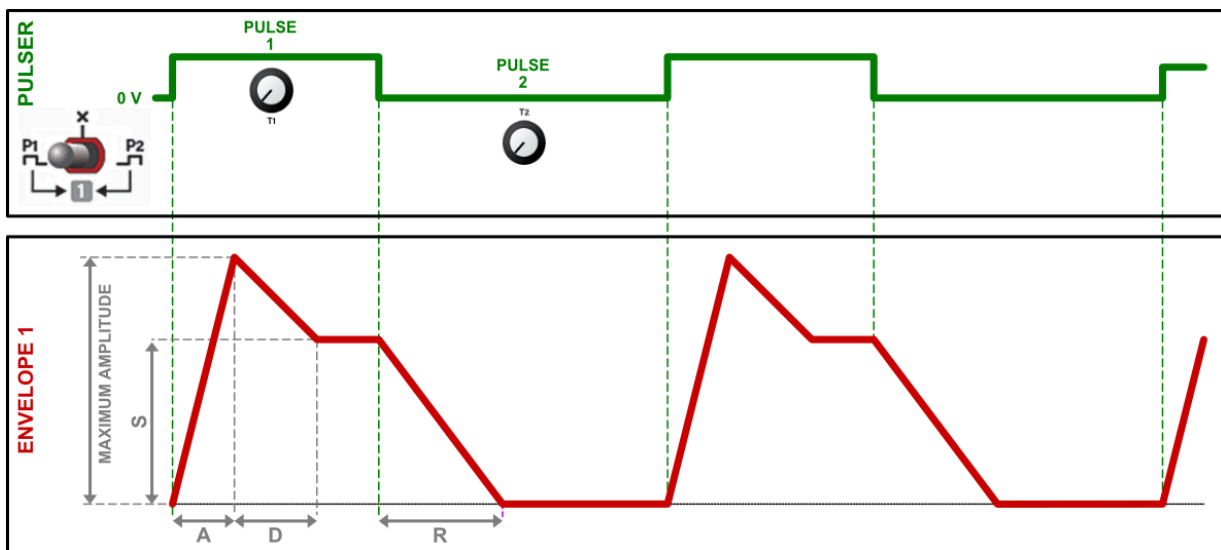

EXAMPLE 3 : In the following example, we've inverted the Pulser for Envelope 1. So **ENV 1 PULSE SOURCE [3.9] = P2** ; PULSE 2 (which is now the HIGH gate) is longer than **A+D** ; PULSE 1 (which is now the LOW gate) is longer than **R**.

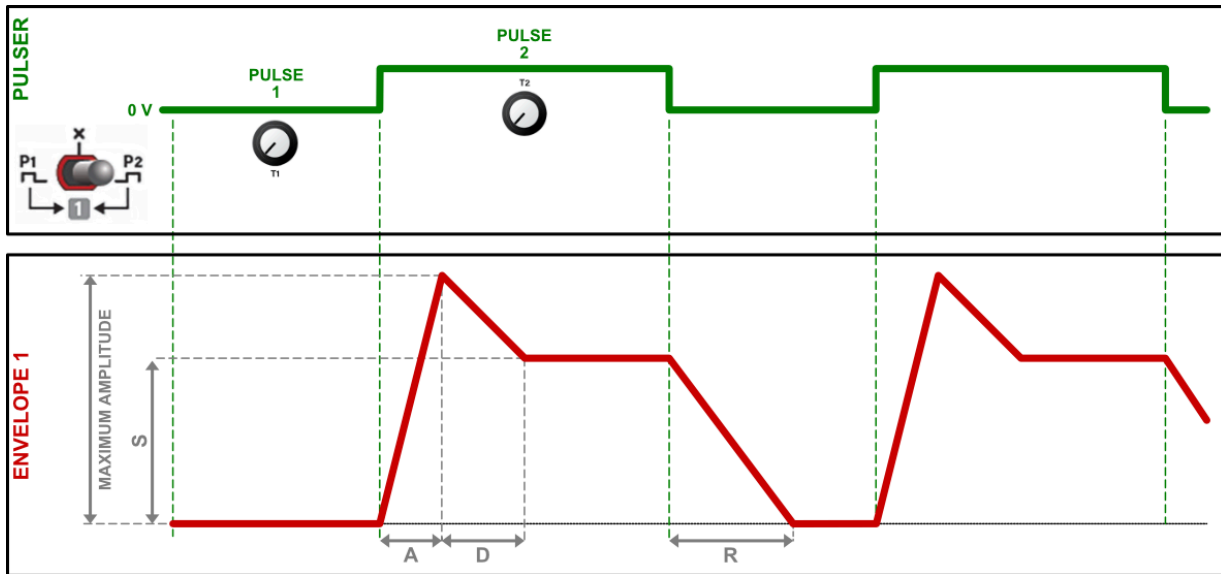

EXAMPLE 4 : In the following example, **ENV 1 PULSE SOURCE [3.9] = P1** ; PULSE 1 is shorter than **A** ; PULSE 2 is longer than **R**.

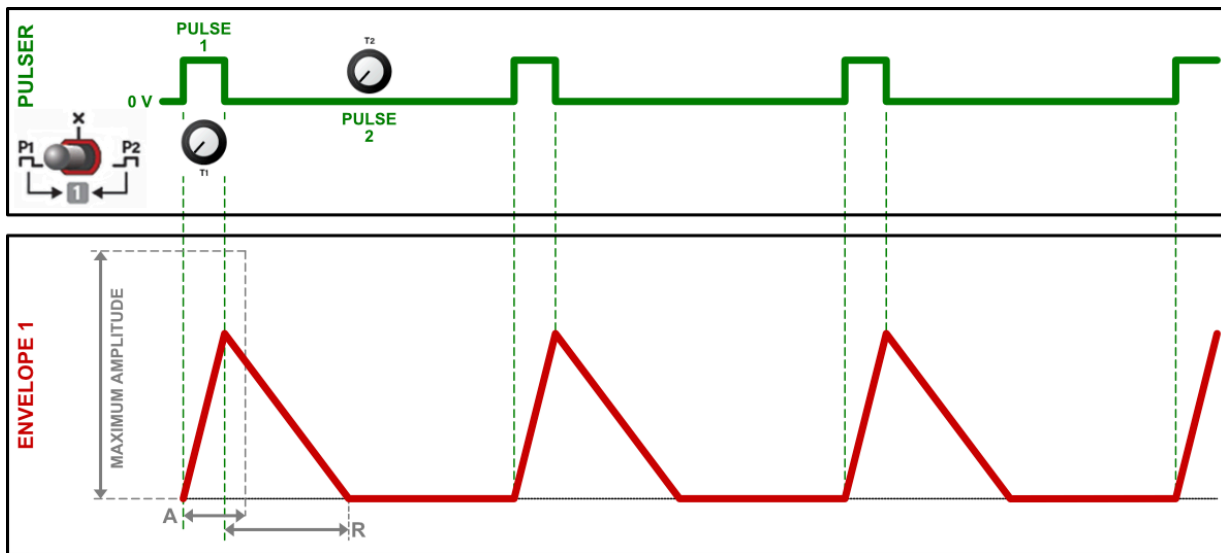

EXAMPLE 5 : In the following example, we're making a cycling trapezoid by setting **S** to the maximum. **ENV 1 PULSE SOURCE [3.9] = P1** ; PULSE 1 is longer than **A** ; PULSE 2 is longer than **R**.

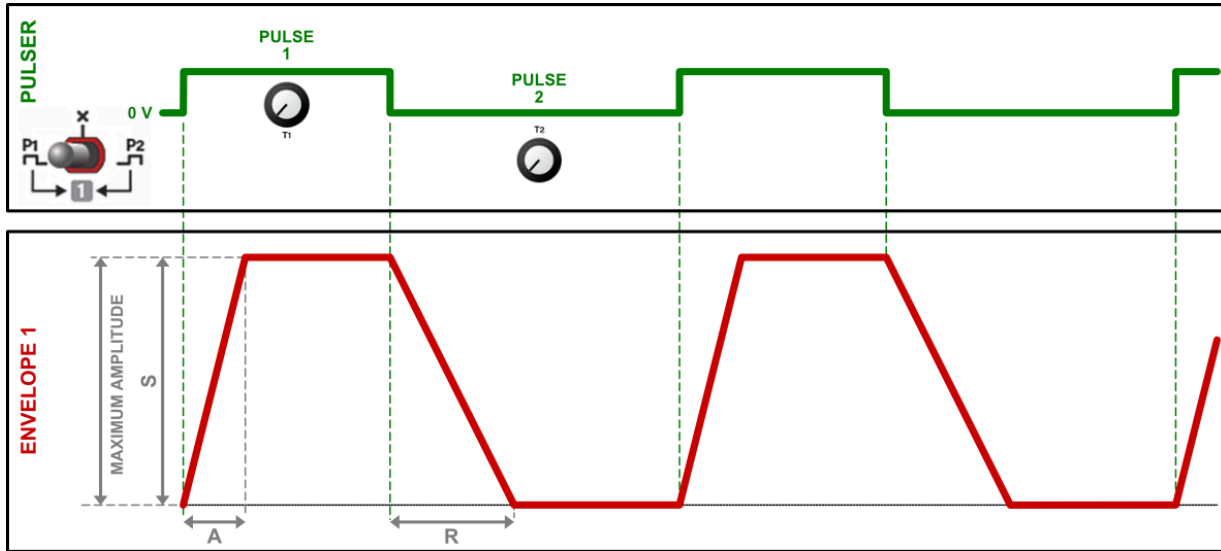

EXAMPLE 6 : In the following example, we're using the Pulser to gate both envelopes — each with different ADSR settings. **ENV 1 PULSE SOURCE [3.9] = P1** ; **ENV 2 PULSE SOURCE [3.10] = P2** . Note the complex unipolar LFO shapes that can be created, particularly when the two envelopes are merged externally.

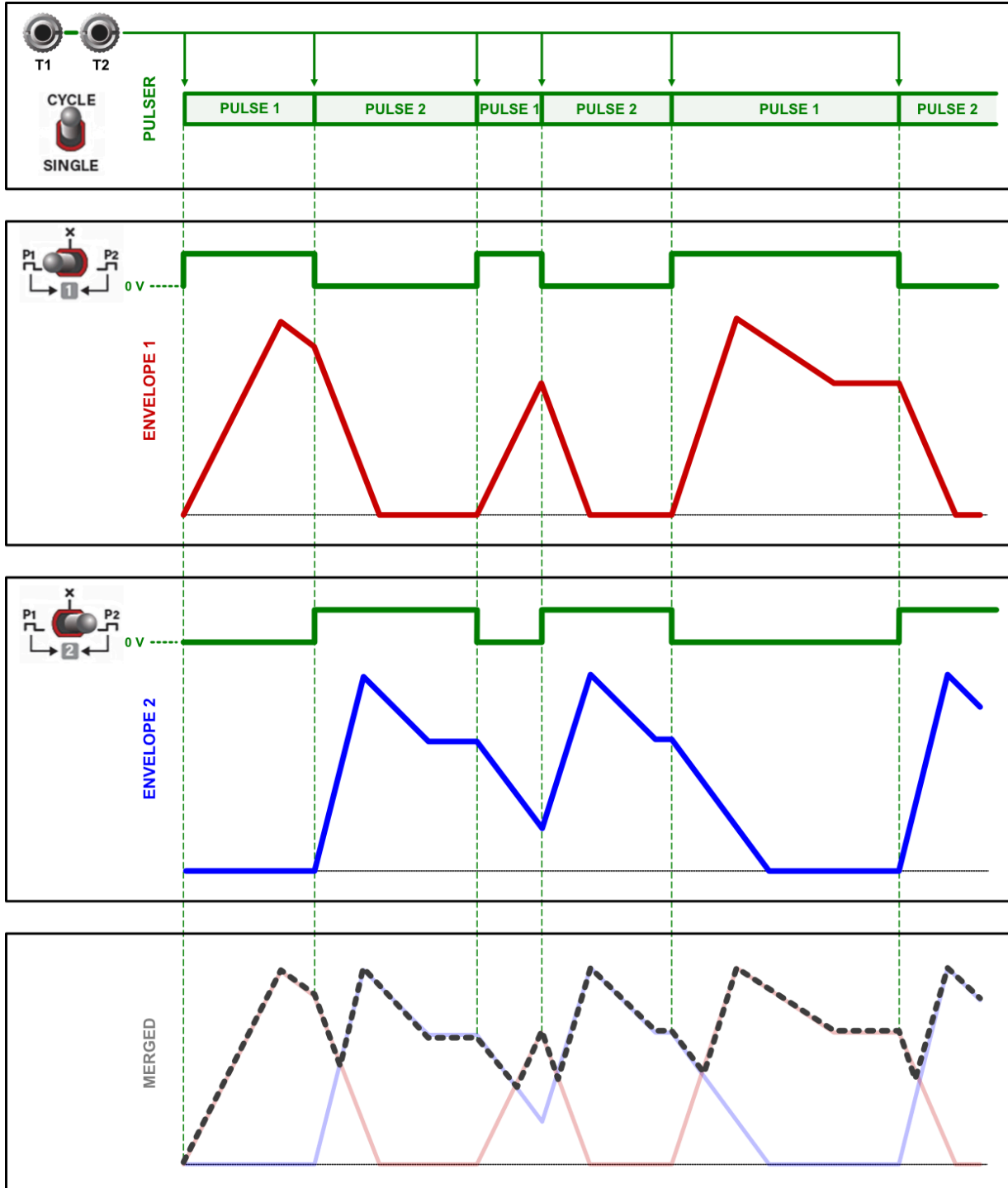

EXAMPLE 7 : In the following example, we use external CV to dynamically alter both **T1** and **T2**, and again use the Pulser to gate both envelopes (each with the same ADSR values as the previous example). **ENV 1 PULSE SOURCE [3.9] = P1** ; **ENV 2 PULSE SOURCE [3.10] = P2** . Note the complex and varying unipolar LFO shapes that can be created, particularly when the two envelopes are merged externally.

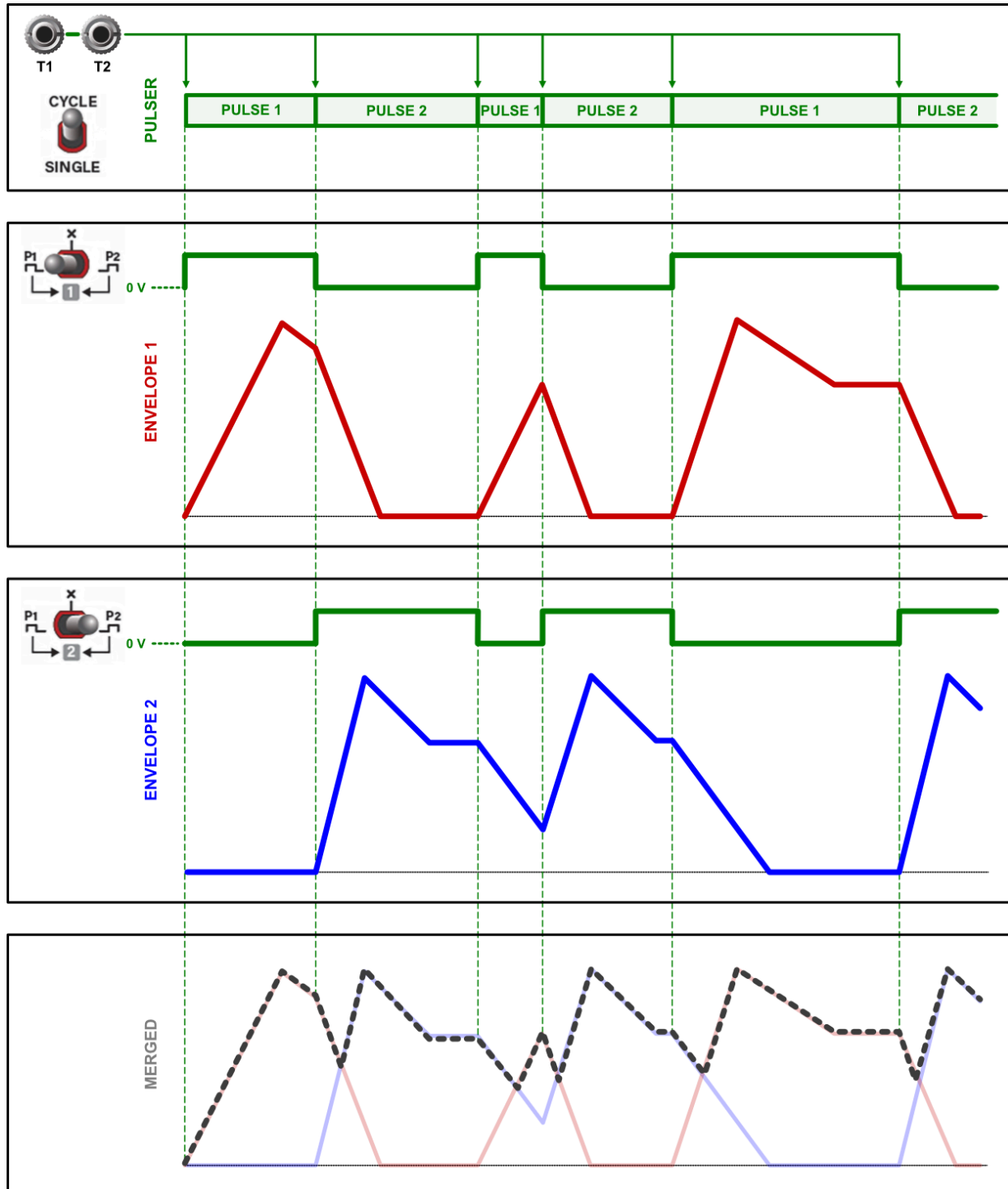

TECHNICAL SPECIFICATIONS

Width	14 hp
Maximum Depth	35 mm
Current Draw	66 mA @ +12V 49 mA @ -12V