

soundhack SPECTRAPAON

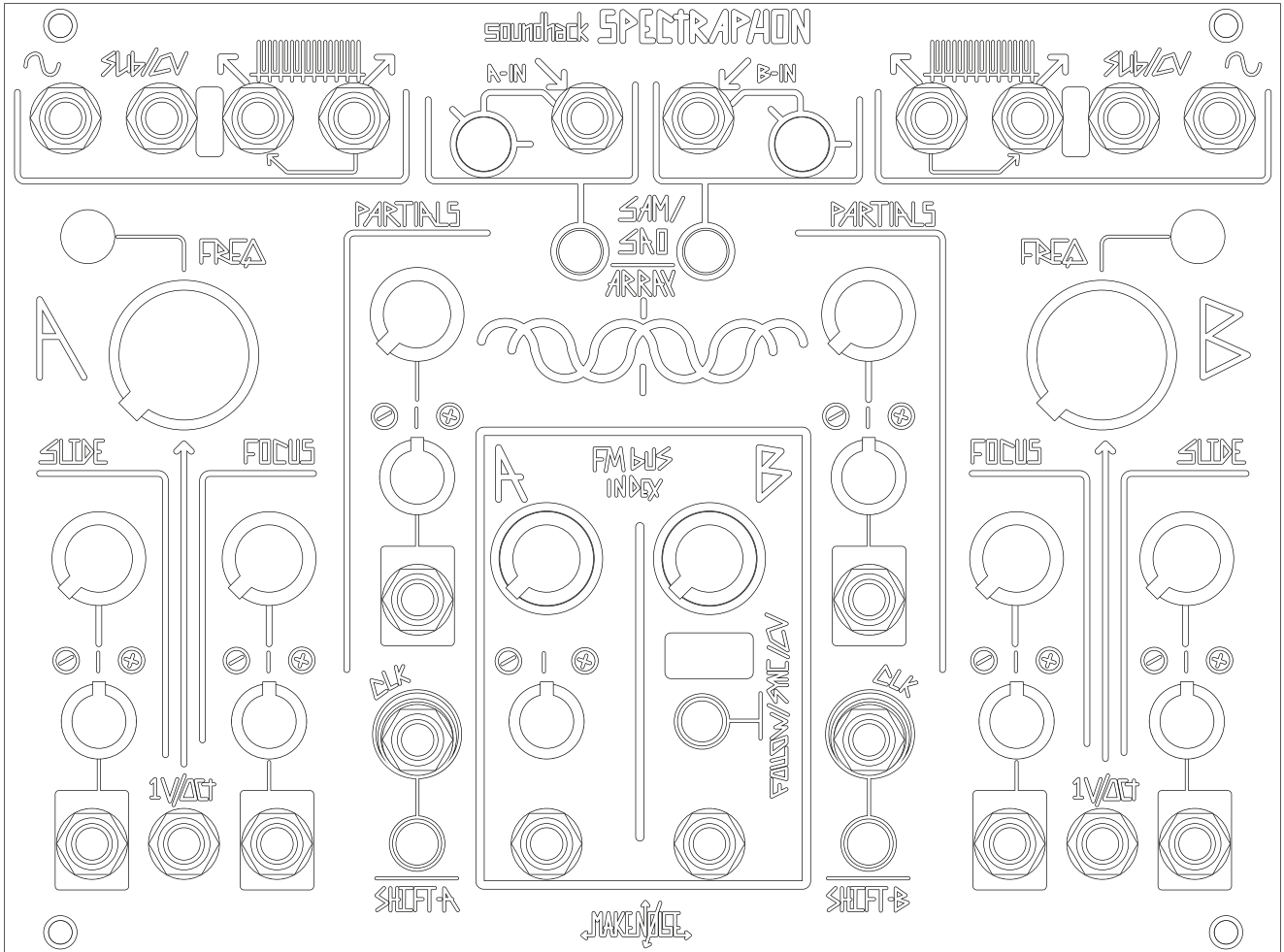

MAKE NOISE

TABLE OF CONTENTS

- FCC
- LIMITED WARRANTY
- INSTALLATION
- INTRODUCTION
- A TECHNICAL NOTE ON THE HARDWARE
- PANEL CONTROLS AND INPUTS/OUTPUTS
- WHAT ARE SPECTRA?
- THE SPECTRAPHON'S OUTPUTS
- BUTTONS AND DISPLAY
- FREQUENCY AND PARTIALS CONTROLS
- SPECTRAL AMPLITUDE MODULATION MODE (SAM)
- SPECTRAL ARRAY OSCILLATION MODE (SAO)
- SELECTING ARRAYS
- CREATING ARRAYS
- MODULATION AND CLOCKING
- SPECTRANOISE UPDATE
- TIPS AND TRICKS
- APPENDIX: THE MICROSD CARD
- SP38 CHANGELOG
- SP52 CHANGELOG
- SP67 CHANGELOG





This device complies with Part 15 of the FCC Rules. Operation is subject to the following two conditions: (1) this device may not cause harmful interference, and (2) this device must accept any interference received, including interference that may cause undesired operation.

Changes / modifications not approved by the Make Noise Co. could void the user's authority to operate the equipment.

This equipment has been tested and found to comply with the limits for a Class A digital device, pursuant to part 15 of the FCC Rules. These limits are designed to provide reasonable protection against harmful interference when the equipment is operated in a commercial environment. This equipment generates, uses, and can radiate radio frequency energy and, if not installed and used in accordance with the instruction manual, may cause harmful interference to radio communications.

makenoisemusic.com
Make Noise Co., 414 Haywood Road, Asheville, NC 28806



LIMITED WARRANTY

Make Noise warrants this product to be free of defects in materials or construction for a period of one year from the date of purchase (proof of purchase/invoice required).

Malfunction resulting from wrong power supply voltages, backwards or reversed eurorack bus board cable connection, abuse of the product, removing knobs, changing faceplates, or any other causes determined by Make Noise to be the fault of the user are not covered by this warranty, and normal service rates will apply.

During the warranty period, any defective products will be repaired or replaced, at the option of Make Noise, on a return-to-Make Noise basis with the customer paying the transit cost to Make Noise.

Make Noise implies and accepts no responsibility for harm to person or apparatus caused through operation of this product.

Please contact technical@makenoisemusic.com with any questions, Return To Manufacturer Authorization, or any needs & comments.

<http://www.makenoisemusic.com>



Spectraphon Credits

DSP Designer and Firmware Engineer: Tom Erbe
Hardware Engineer, Design Engineer: Tony Rolando
Lead Hardware Engineer: Jeff Snyder
Lead Beta Tester: Walker Farrell

Manual: Walker Farrell with illustrations and layout by Lewis Dahm

The Make Noise Crew in West Asheville: Tony, Kelly, Bayley, Devin, Eric, Jake, Jon, Lee, Lewis, Mike, Natasha, Peter, Ryan, Sam, & Walker

Special Thanks to the Beta Testers!



INSTALLATION

Electrocution hazard!

Always turn the Eurorack case off and unplug the power cord before plugging or unplugging any Eurorack bus board connection cable. Do not touch any electrical terminals when attaching any Eurorack bus board cable.

The Make Noise Erbe-Verb is an electronic music module requiring 230mA of +12VDC and 55mA of -12VDC regulated voltage and a properly formatted distribution receptacle to operate. It must be properly installed into a Eurorack format modular synthesizer system case.

Go to <http://www.makenoisemusic.com/> for examples of Eurorack Systems and Cases.

To install, find 34HP in your Eurorack synthesizer case, confirm proper installation of Eurorack bus board connector cable on backside of module (see picture below), plug the bus board connector cable into the Eurorack style bus board, minding the polarity so that the RED stripe on the cable is oriented to the NEGATIVE 12 Volt line on both the module and the bus board. On the Make Noise 6U or 3U Busboard, the negative 12 Volt line is indicated by the white stripe.

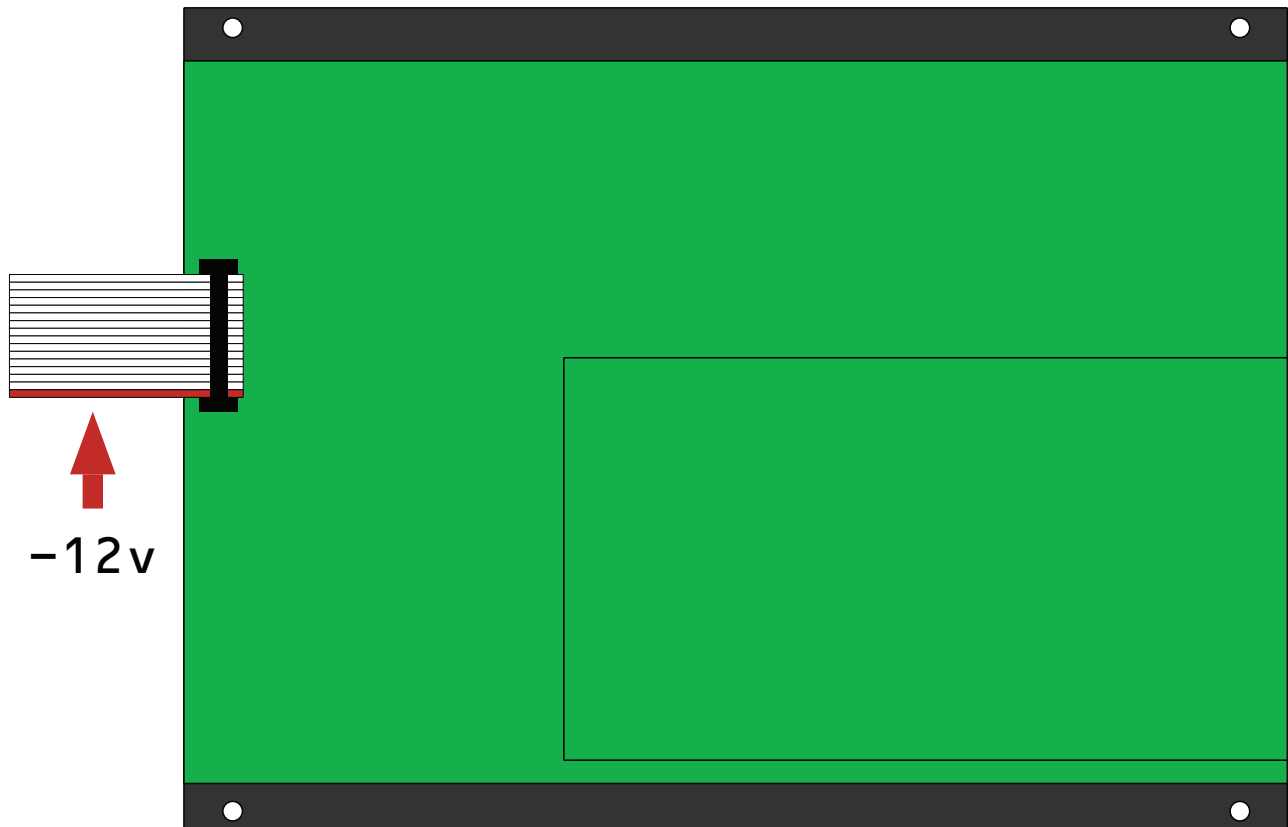

Please refer to your case manufacturer's specification for location of the negative supply.



INTRODUCTION

The Make Noise/soundhack Spectraphon is a dual Spectral Oscillator. Coded by Tom Erbe of soundhack, it uses real-time spectral analysis and resynthesis to create new sounds from those that already exist. It is inspired by classic electronic musical instruments of the past, including spectral processors, additive synthesis, vocoders, and “resonators.” Elements of its sonic palette are inspired by the Buchla 296 and Touché, but it takes a physical form more resembling the classic analog dual “complex” oscillator in the lineage of the Buchla 259 and the Make Noise DPO.

The Spectraphon is the first module to be built by Make Noise on our brand new digital hardware platform. This hardware, engineered by Jeff Snyder and Tony Rolando, provides more i/o at higher resolutions, and a lower noise floor than we have ever had access to in a digital module before. We have taken advantage of this new hardware power to unleash Tom Erbe’s DSP code to a previously unattainable degree. In short, it is the most sonically powerful digital module we have yet created.

The Spectraphon is laid out as two nearly identical sides, A and B, which are roughly mirrors of each other. Each side operates independently as an Oscillator in one of two modes: Spectral Amplitude Modulation (henceforth abbreviated as “SAM”) and Spectral Array Oscillation (henceforth abbreviated as “SAO”). In any combination of these modes they can also interact via the internal FM Bus, the Follow and Sync modes, and by patching them together.

In SAM, instead of oscillating at all times like an analog VCO, sound at the Spectraphon’s input is used to modulate the amplitude of a set of harmonics of a fundamental frequency set by the Slide control. The Focus controls further select the areas of harmonic emphasis, and the result, called a spectrum, appears at the Odd and Even harmonic outputs. In SAM the Spectraphon can be sequenced and frequency modulated like any VCO - and the Sine wave output is also always active. At any time the current spectrum can be used to create an Array for later use in Oscillator mode.

In SAO, the Spectraphon operates even more like an analog VCO: it oscillates at all times, with the spectrum at the Odd and Even harmonic outputs being drawn from stored collections of spectra called Arrays. (Arrays are created from the Spectraphon’s activity while in SAM.) In SAO, the Spectraphon’s Slide and Focus controls are used to select the currently active spectrum within the Array.

In either mode (SAM or SAO), the FM Bus will create high definition internal frequency modulation from the opposing side of the Spectraphon. Unlike with analog VCOs, the core of the Spectraphon oscillator is not affected by this FM of the harmonic outputs: the sine and Sub outputs will still output the original core frequency even when the FM depth goes to its extremes. This also means that tuned FM can be performed in both directions at once without causing cross-modulation or feedback.



INTRODUCTION, CONT.

Also in either mode, the Partials control works as a combined amplitude and timbre control for the Odd and Even harmonic outputs. It increases the relative loudness of the harmonics of the current spectrum as it increases, beginning with silence at counterclockwise, adding lower harmonics at low values, then through middle and high harmonics, and generating all harmonics at their full amplitude according to the current spectrum at maximum. The odd and even harmonics are increased alternately up the control, which can be useful for animation when parallel processing these outputs or using them in a stereo setup.

Each Side of the Spectraphon has, in addition to Odd and Even harmonic outputs, a Sine and a Sub/CV output. The Sine wave output always oscillates at the current core frequency as set by Pitch, regardless of mode, and regardless of the activity at the other outputs. By default, Sub/CV outputs an Envelope Follower for the Input (in SAM) or a sub-octave waveform (in SAO).

The B side of the Spectraphon can also be set to Follow or Sync. Follow turns the B Pitch control into a pitch offset that is added or subtracted from the A side's current frequency. In practice, this lets Side A control the Pitch of Side B, which is useful for dual oscillator patches, tuned FM etc. Sync maintains this Following behavior, and additionally hard syncs Side B to the current frequency of Side A, turning Side B's pitch controls into combined pitch/timbre control.

The Pitch, FM, Partials, and Follow/Sync operations, as well as the Sine wave outputs, all work identically in SAM and SAO. This means that in many respects the Spectraphon can be used as you would use a dual "complex" oscillator even when the two sides are not in the same mode. It could be thought of as a complex oscillator that is fed or "driven" by external sound.

The Spectraphon is a digital/analog musical instrument that is not suitable for laboratory use.



A TECHNICAL NOTE ON THE HARDWARE

The new Make Noise DSP hardware features 2 Inputs and 8 outputs of low noise, high dynamic range, fully DC Coupled Digital Signal Processing power. We used a 5 volt CODEC which helped us achieve excellent SNR and yields an impressive input dynamic range that is around 12 to 30 dB better than possible with low-power 3.3 volt CODECs commonly used in synthesizer modules. Best of all, this new DSP platform is DC coupled, resulting in nearly flat frequency response down to 0Hz, giving the possibility for a huge, clean sound. Having 8 outputs instead of the more common 2 IN/ 2 OUT configuration allows us to approach simultaneous outputs previously seen only in our analog modules such as QPAS, XPO or DPO. The signal processing is achieved with modern ARM Cortex-H7 MCU running at 480MHz. Plenty of SDRAM and FLASH memory means big buffers and larger stored tables, and that ultimately means code can run faster. Firmware updates are handled using the onboard micro SD Card interface so updating firmware is as easy as dragging the new firmware file onto the Micro SD Card.

Specs:

- ADC Dynamic Range: 114dB
- DAC Dynamic Range: 110dB
- DAC THD + Noise: -110dB
- Up to 24bit 192khz bit depth and sample rate
- ARM Cortex-H7 MCU, running at 480MHz
- 64MB of SDRAM
- 2MB FLASH



PANEL CONTROLS

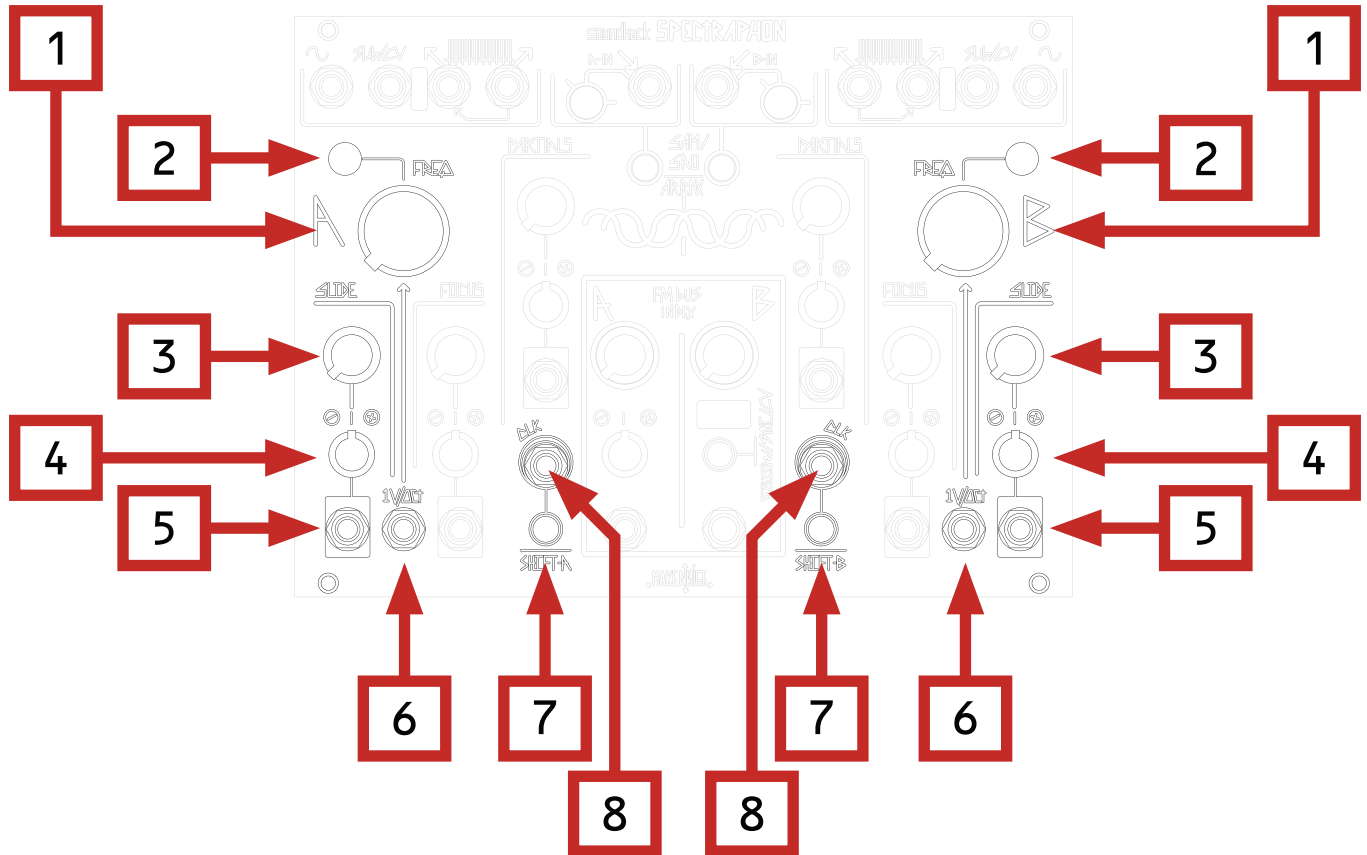

SIDE A & B

1. **Frequency Panel Control:** Sets the Frequency of the Side. Summed with Fine-Tune and 1v/oct.
2. **Fine Tune:** Fine Tune of the Side's Frequency.
3. **Slide:** Modulates the current Spectrum, depending on mode.
4. **Slide Attenuverter:** Bipolar input attenuverter for Slide.
5. **Slide CV Input:** CV Input for Slide.
6. **1v/oct:** Sets core Frequency of the Side via external control, tracks one volt per octave.
7. **Shift Button:** Press to manually Clock the Spectraphon. Hold to access Shift-functions on other buttons (Array Creation, CV Type, Shift Array)
8. **Clock Input:** Clocks the Spectraphon. Steps through the Spectra of the current Array (SA0), writes Spectrum during Array Creation (SAM), clock input for CV outputs when applicable.



PANEL CONTROLS

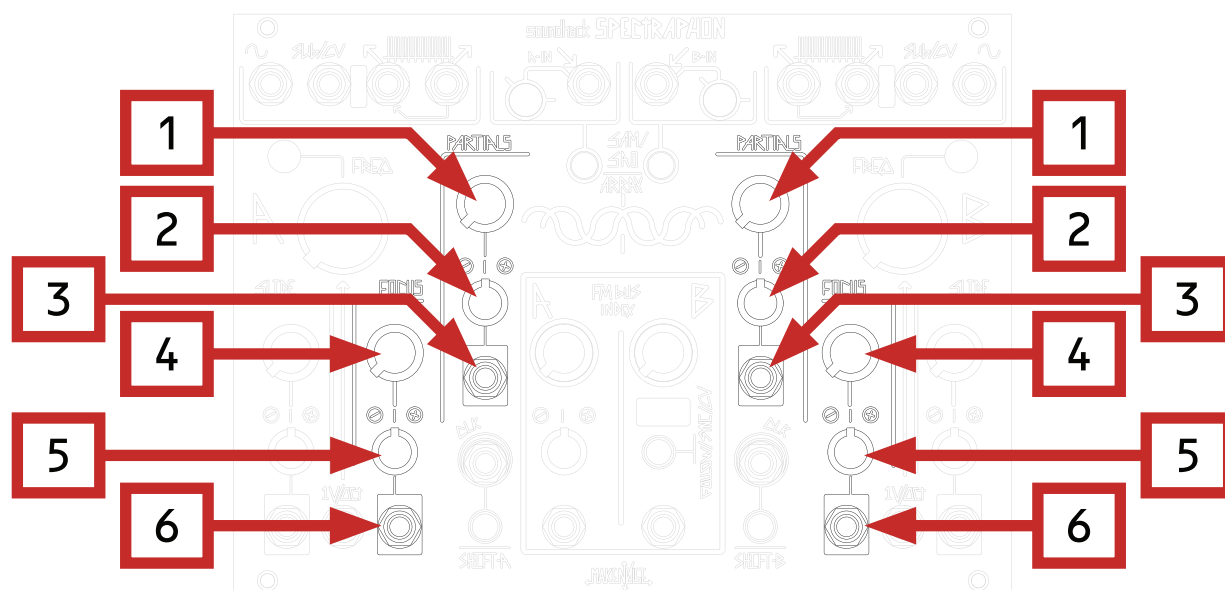

SIDE A & B

1. **Partials Panel Control:** Sets number of Partials audible at Odd/Even Harmonic Outputs.
2. **Partials Attenuverter:** Bipolar input attenuverter for Partials.
3. **Partials CV Input:** CV Input for Partials.
4. **Focus Panel Control:** Modulates the current Spectrum, depending on mode.
5. **Focus Attenuverter:** Bipolar input attenuverter for Focus.
6. **Focus CV Input:** CV Input for Focus.



PANEL CONTROLS

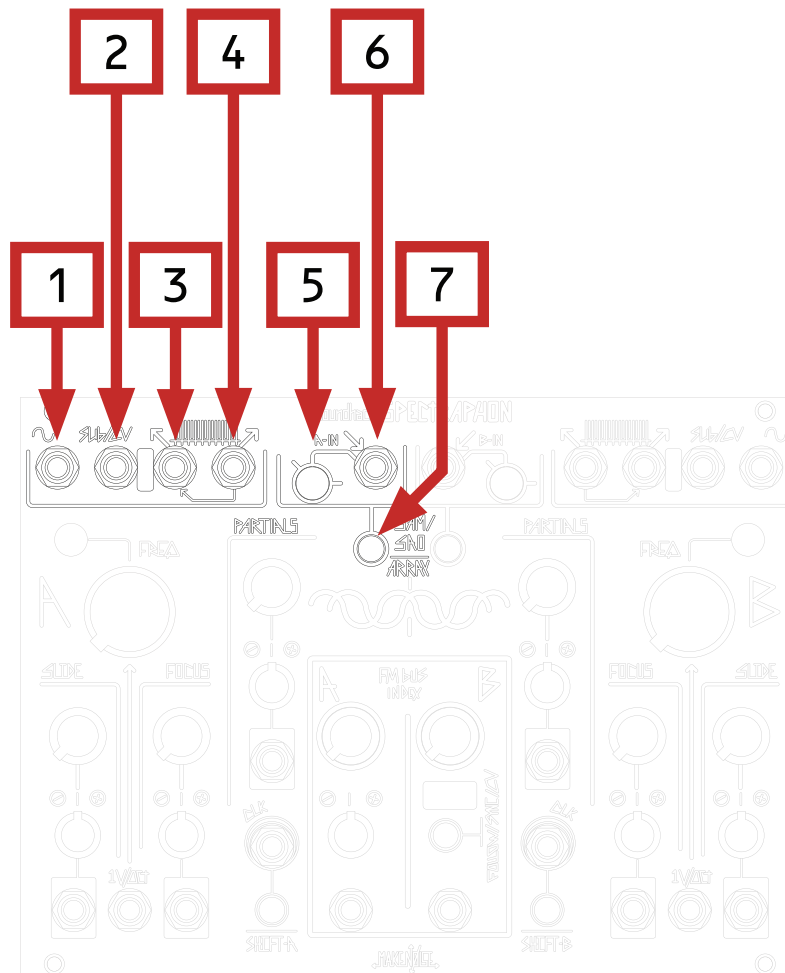

Side A Inputs and Outputs

1. **Sine Wave output:** Sine wave that oscillates at A Core Frequency.
2. **Sub/CV Output:** Sub/CV Output for Side A.
3. **Odd Harmonic Output:** Odd harmonics for Side A.
4. **Even Harmonic Output:** Even harmonics for Side A. Normalled to Odd Harmonic Output.
5. **A-In Panel Control:** Sets Input Level (SAM) or Even Harmonic Offset (SAO).
6. **A-In CV Input:** CV Input for A-In. Use depends on mode.
7. **SAM/SAO/Array Button:** Switches between SAM and SAO for Side A. Creates Array when pressed while holding Shift-A in SAM.



PANEL CONTROLS

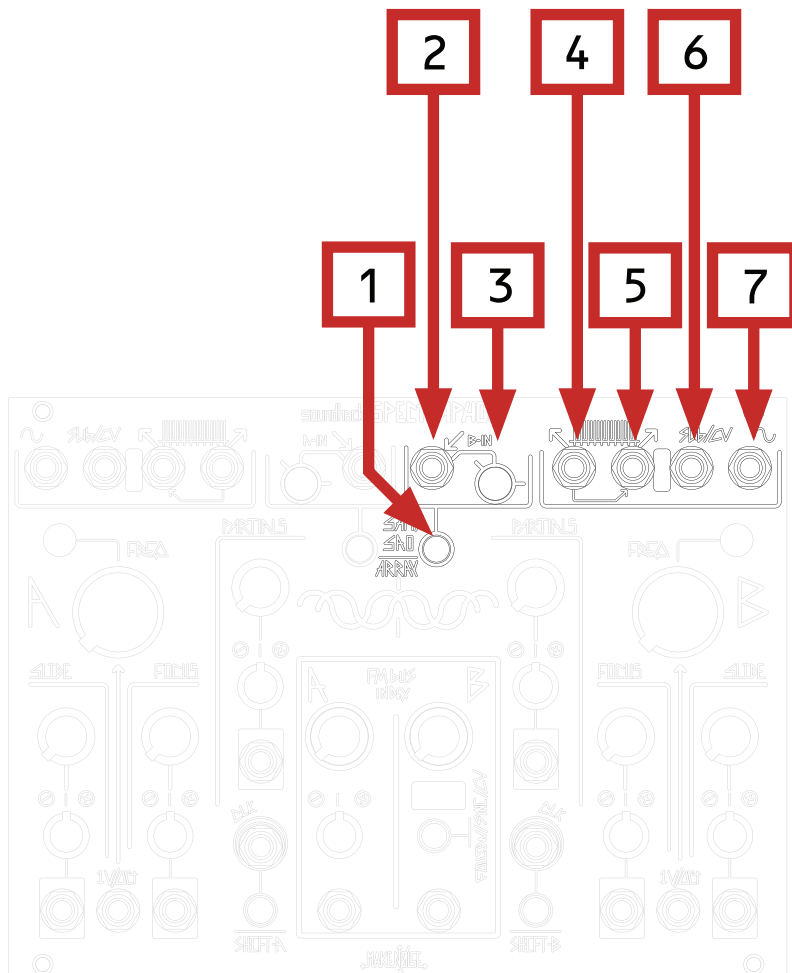

Side B Inputs and Outputs

1. **SAM/SAO/Array Button:** Switches between SAM and SAO for Side B. Creates Array when pressed while holding Shift-B in SAM.
2. **B-In CV Input:** CV Input for B-In. Use depends on mode.
3. **B-In Panel Control:** Sets Input Level (SAM) or Even Harmonic Offset (SAO).
4. **Even Harmonic Output:** Even harmonics for Side B. Normalled to Odd Harmonic Output.
5. **Odd Harmonic Output:** Odd harmonics for Side B.
6. **Sub/CV Output:** Sub/CV Output for Side B.
7. **Sine Wave output:** Sine wave that oscillates at B Core Frequency.



PANEL CONTROLS

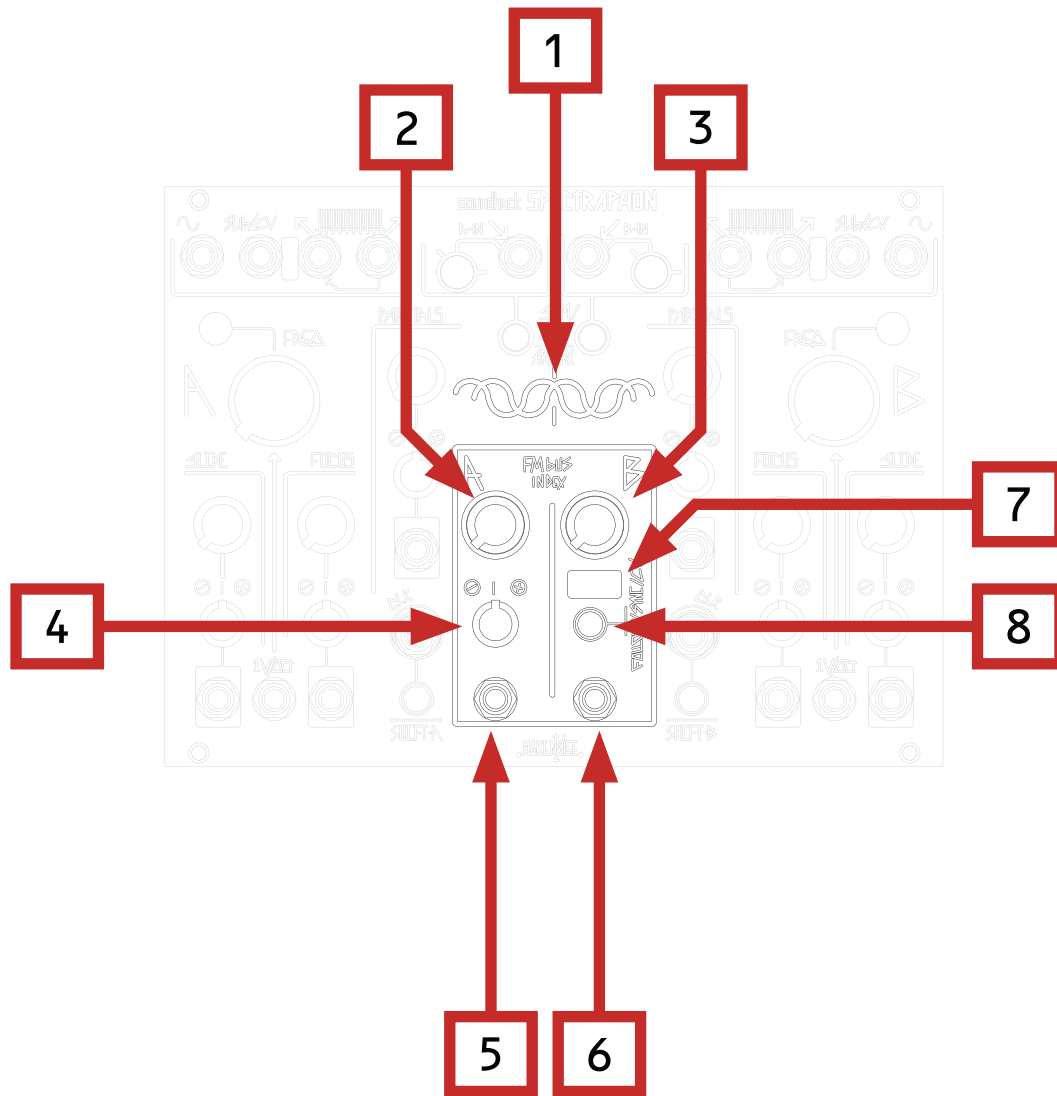

FM Bus

1. **Array Binary:** Displays current setting of A and B Slide/Focus controls. Displays current Array during Array Selection. Displays current firmware version during startup.
2. **A FM Index Panel Control:** Sets depth of internal Frequency Modulation from B to A.
3. **B FM Index Combo Pot:** Sets depth of internal Frequency Modulation from A to B. Become an input attenuator when B FM Index CV Input is patched.
4. **A FM Index CV Input Attenuverter:** Bipolar CV Input attenuverter for A FM Index.
5. **A FM Index CV Input:** CV Input for A FM Index.
6. **B FM Index CV Input:** CV Input for B FM Index.
7. **Tuning Beacon:** Indicates Tuning Ratios of A to B. Lights Green for Octave, Fourth, Fifth, and Red for Third and Sixth.
8. **Follow/Sync/CV Button:** Sets B into Follow or Sync Modes. Switches CV Mode for Sub/CV output when pressed while holding a Shift Button.



WHAT ARE SPECTRA?

The Fourier Theorem states that a periodic function which is reasonably continuous may be expressed as the sum of a series of sine or cosine terms (called the Fourier series), each of which has specific amplitude and phase coefficients known as Fourier coefficients.

If the above reads like science rather than music, here is a translation:

“Any musical tone with a distinct pitch can be expressed as a set of harmonic sine waves of varying frequencies and amplitudes.”

A classic "real world" example of this is the standard waveforms of analog synthesizers, which are chosen partially for their different harmonic makeups when analyzed: Sawtooth waves contain all harmonics; Square waves contain every other harmonic (half the harmonics); Sine waves contain only one harmonic (the first).

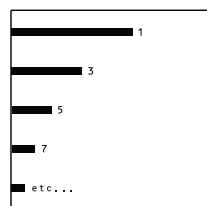
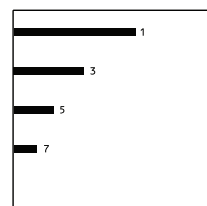
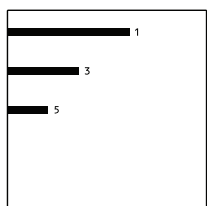
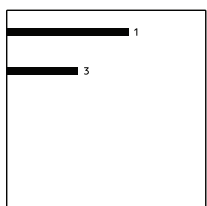
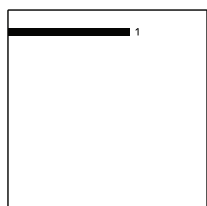
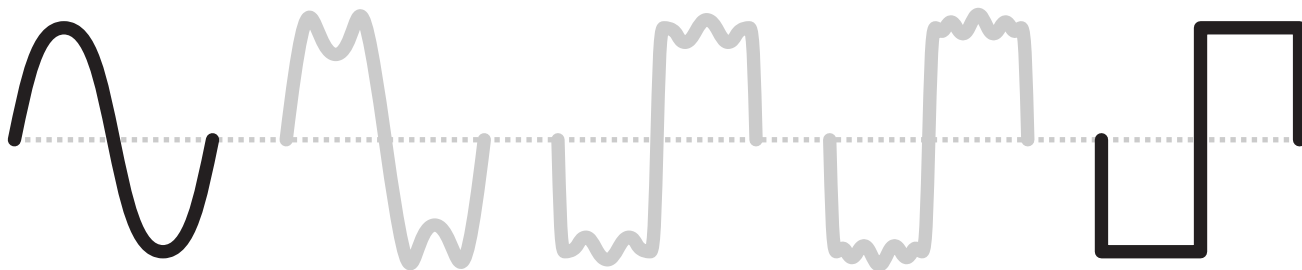
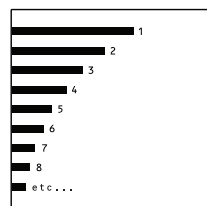
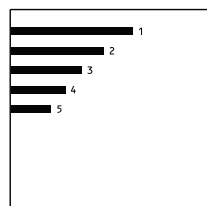
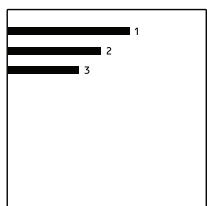
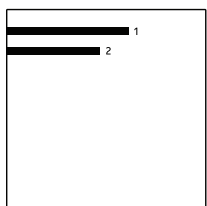
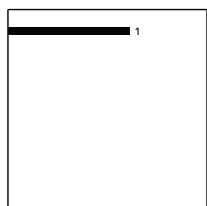
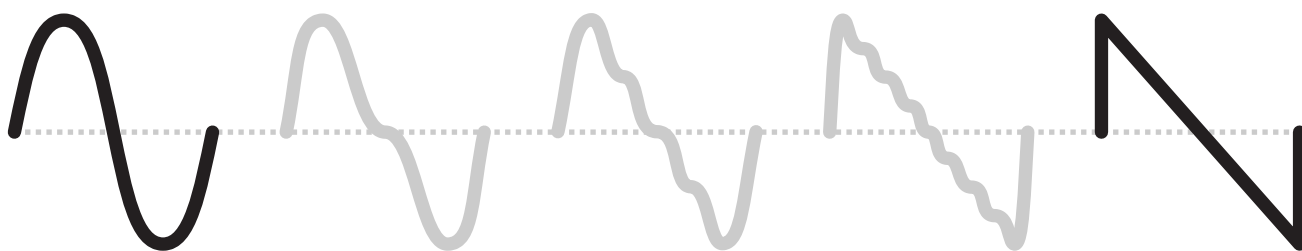

WHAT ARE SPECTRA?

In the Spectraphon, and in this manual, any collection of harmonics at varying amplitudes can be referred to as a **spectrum** (plural: **spectra**). The Spectraphon is specially made to generate many varieties of spectra at its Odd and Even harmonic outputs, a large collection of which can be generated by modulating the Spectraphon with external sounds at the input in **Spectral Amplitude Modulation (SAM)**, and further explored in **Spectral Array Oscillation (SAO)** via collections of spectra called Arrays.

It is important to note that **Arrays of spectra are not sound recordings**. Instead, each spectrum is a collection of values denoting the amplitude of each harmonic. The actual pitch of these harmonics at the output will be determined by the Pitch settings of the Spectraphon.

Any given spectrum is only one part of an Array as used in SAO. The Array can contain up to 1024 spectra (see “creating Arrays” for more information). The Slide and Focus controls and CV inputs, as well as the Clock input, can be used to dynamically select the current spectrum. Each spectrum is a potentially unique set of harmonics.



THE SPECTRAPHON'S OUTPUTS

Each Side of the Spectraphon features four outputs.

The primary outputs are the Odd and Even outputs.

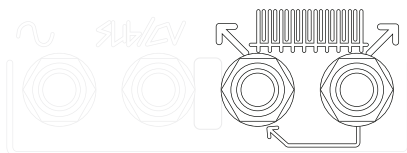

These contain the odd and even harmonics, respectively, of the output of the Spectraphon, as determined by the current spectrum and any FM or Partial modulation. The Even output is normalized such that when it is unpatched, both outputs are summed together in the Odd output. When in SAO, the Even output can also be offset in pitch by up to an octave using the A/B-In attenuator, or modulated in pitch separately using an external signal.

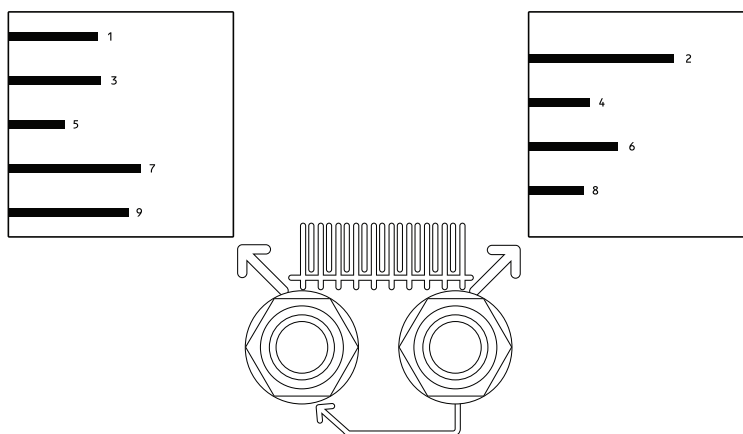

The Sine wave output always oscillates at the core frequency of the Side as set by Pitch, Fine Tune, and 1v/oct input - even under heavy frequency modulation (something that is not possible with analog VCOs).



The Sine output is unaffected by all other controls including FM and Partial modulation. It is useful for keeping a strong fundamental during heavy harmonic modulation.



THE SPECTRAPHON'S OUTPUTS

The Sub/CV output is an Envelope Follower (SAM) or Sub-Oscillator (SAO).



The Envelope Follower (SAM) will create modulation in sync with any changes in amplitude in the source material.

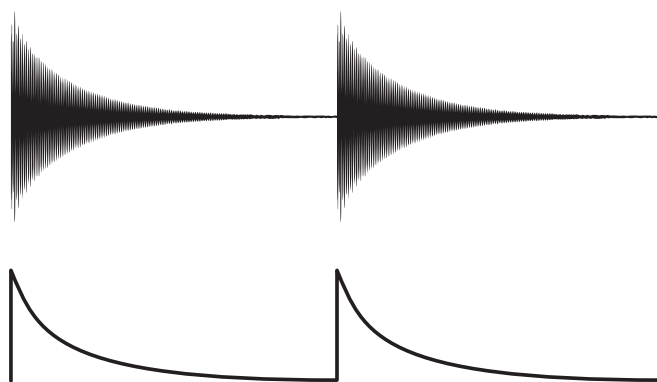

The Sub-Oscillator (SAO) will provide a strong deeper signal to use alongside the harmonic outputs.

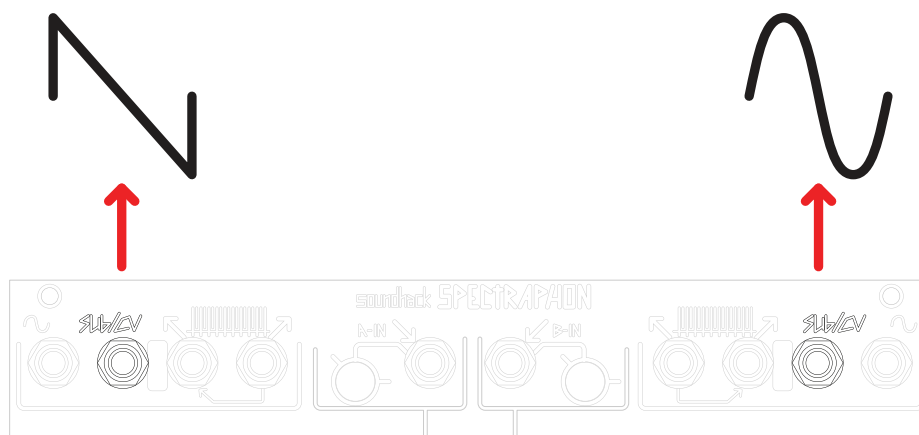

Side A's Sub-Oscillator is a Sawtooth, while Side B's is a Saturated Sine Wave. Alternatively, each Sub/CV output can be set as a clocked modulation output. See "Modulation and Clocking" below.



BUTTONS AND DISPLAY

There are five buttons on the Spectraphon: each Side has a SAM/SAO and a Shift button, and additionally there is the Follow/Sync button.

The **SAM/SAO buttons** switch the respective sides between the modes as listed. The button lights to indicate SAO mode. Note: in firmware sp52 or later, these buttons also access the Noise and Chaos modes.

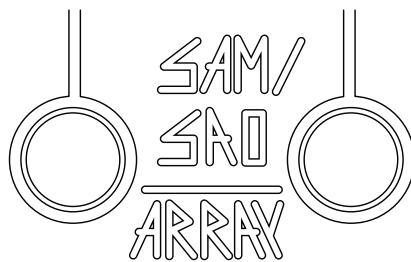

The **Follow/Sync** button selects these operations for Side B. It lights for FOLLOW and flashes for SYNC, or is OFF when neither is selected.

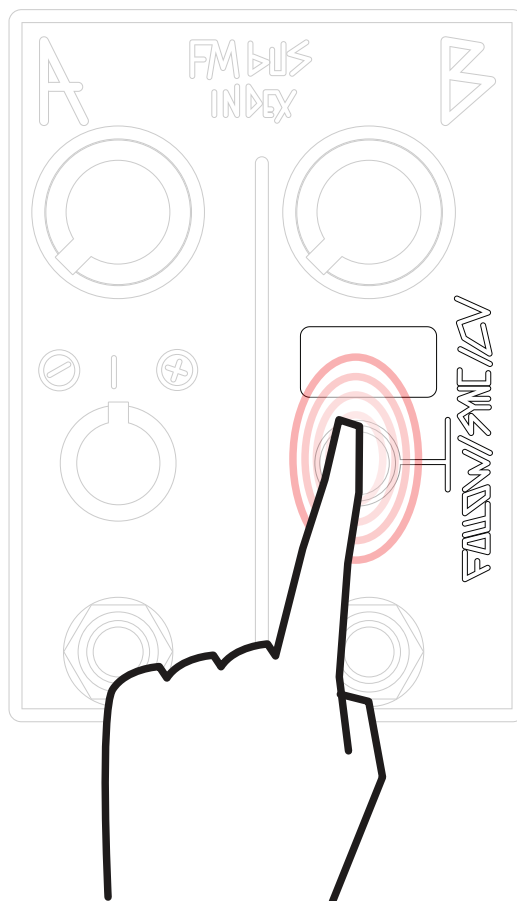

BUTTONS AND DISPLAY

The **Shift button** can be used as a manual Clock (same functions as the Clock input), or can be held to access the Shift functions (written in GOLD) on the other buttons:

- **Shift+ARRAY** begins or ends Array Creation in SAM (per side) (in sp52 or greater, in oscillator modes this button combo switches the Side to low frequency; Shift button stays lit to indicate low frequency)
- **Shift+CV** selects the Sub/CV mode (per side)
- **Shift+Shift** shifts (per side) the Array to be used for SA0 or the spot to be written over when creating an Array in SAM. (in sp38 or greater, hold Shift+Shift for 2 seconds to clear the Array and return to default)

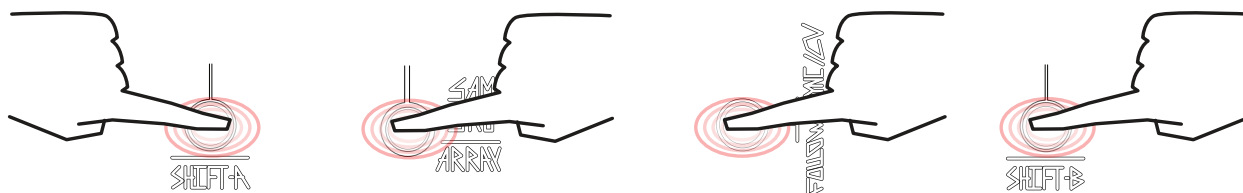

The Tuning Beacon displays information about the tuning relationship between the core frequencies of the two Sides of the Spectraphon. It lights Green for the simplest tuning ratios (octaves (2:1), fifths (3:2), and fourths (4:3)) and Red for the next simplest (major thirds (5:4) and sixths (5:3)). This indicator can be especially useful for “dual VCO” patches or when using tuned FM and/or Follow. (Note these are just ratios rather than equal temperament intervals).

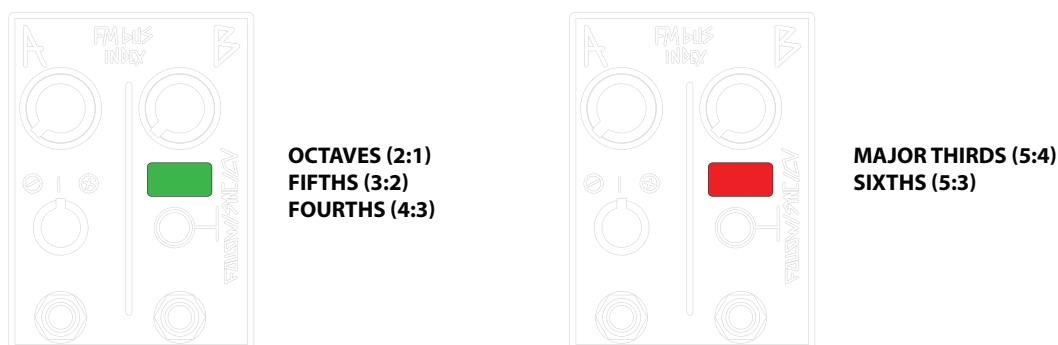

The Array Binary consists of four colored LEDs that indicate the current values of the Slide and Focus controls on each Side of the Spectraphon. (In sp52 or greater, these are used to indicate the current Mode). While selecting Arrays, the Array Binary shows the currently selected Array using the four colored LEDs to show a 4 bit binary number.

$$\text{Four white LEDs} = 0$$

$$\text{Four LEDs (3 white, 1 red)} = 1$$

$$\text{Four LEDs (2 white, 2 green)} = 8$$

$$\text{Four LEDs (2 white, 1 green, 1 red)} = 15$$



FREQUENCY AND PARTIALS CONTROLS

Most of the controls of Spectraphon work identically regardless of whether it is in SAM or SAO. (The main exceptions are the A-In and B-In, and the Slide and Focus controls.) See the Appendix "sp52 update" for their functions in Noise and Chaos modes.

Partials sets the relative emphasis of upper and lower harmonics at the Odd and Even outputs. It increases the relative loudness of the harmonics of the current spectrum as it increases, beginning with silence at full counterclockwise, adding lower harmonics at low values, then through middle and high harmonics, and generating all harmonics at their full amplitude according to the current spectrum at fully clockwise. The odd and even harmonics are increased alternately up the control, which can be useful for animation when parallel processing these outputs or using them in a stereo setup.

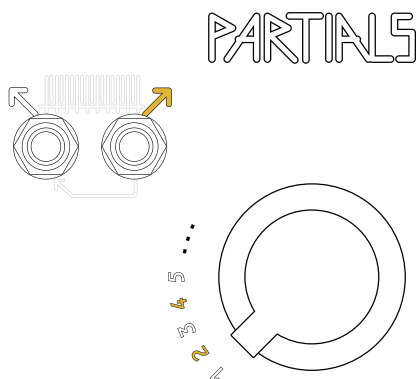

Frequency, together with the fine-tune control and the 1v/oct input, sets the core frequency of the Side. The sine wave output can always be heard at this core frequency.

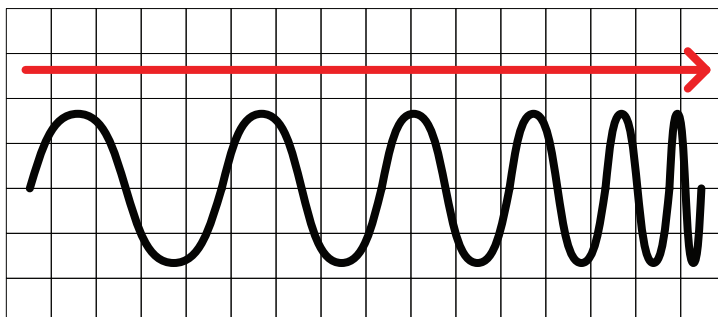
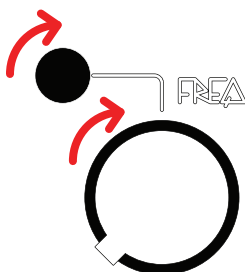

FREQUENCY AND PARTIALS CONTROLS

In SAM, incoming audio is interpreted as a set of harmonic amplitudes as they exist in relation to the core frequency set by Slide. This core frequency denotes the frequency of the first harmonic, while all other harmonics appear as multiples of this core frequency, in amounts determined by Focus. Activity at the Spectraphon's Odd and Even harmonic outputs is based on the resulting spectrum, which is then resynthesized at the current Frequency of the Side. (See the "SAM" and "Creating Arrays" sections for more details).

In SAO, the current spectrum in the Array, output at the Odd and Even outputs, is comprised of harmonics of varying amplitudes at multiples of this core frequency (the spectrum is selected using the Slide and Focus controls). See the "SAO" section for more details.

The **FM Bus** sets the depth of internal frequency modulation between the two sides of the Spectraphon. As the Index control is turned up, the FM depth to the respective side will be increased. This FM Bus generates its FM internally within the Spectraphon algorithm, which gives it several technical advantages:

- It is higher resolution and more "accurate" than any FM that can be generated using a physical input and analog-to-digital conversion
- It can be calculated at this high resolution, even at extreme depths, without altering the core frequency of the oscillator as represented at the Sine and Sub outputs
- It can be performed in both directions at once (A to B and B to A) without causing cross-modulation/feedback (this is not possible with analog VCOs)

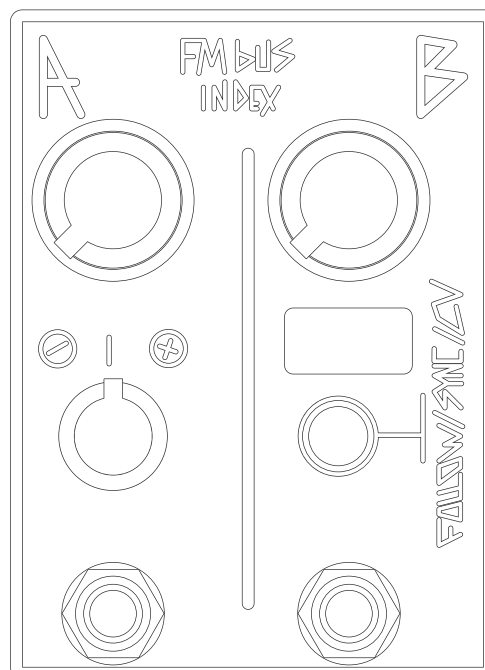

FREQUENCY AND PARTIALS CONTROLS

The Follow/Sync button engages either of two alternate behaviors for Side B:

Follow (button lit) allows Side B to be sequenced in Pitch using Side A. Specifically, it turns Side B's Pitch knob and 1v/oct input into an offset (with zero at ~12:00) that is added to the Pitch as set by the Pitch controls of Side A. This allows for simultaneous control of the pitch of both sides using just Side A, while maintaining a tuning interval of your choice (the Tuning Beacon can be used to quickly select a consonant interval). Whether monitoring the Sides individually, using FM, or spectrally amplitude modulating one side with the other, keeping the Sides in tune with each other has many uses. Note: for tuned ratios using Follow, it will be best to turn on the Follow mode first, prior to tuning.

Sync (button flashing) maintains the Follow function, and additionally causes Side B to hard sync to Side A, in other words for the waveform at the output to “reset” every time Side B's core resets, so that the two sides have the same base frequency. The Odd harmonics and Even harmonics sync separately (Side B Odd syncs to Side A Odd, Side B Even syncs to Side A Even). Sync introduces strong (potentially abrasive/“noisy”) harmonics to Side B. Slow modulations of Side B's Pitch while it is Synced will create strong harmonic sweeps.

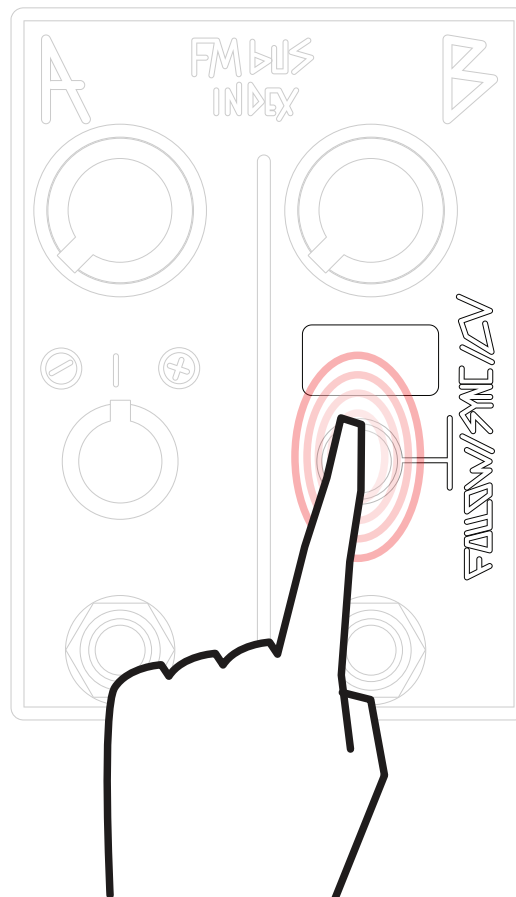

FREQUENCY AND PARTIALS CONTROLS

The Tuning Beacon displays information about the tuning relationship between the core frequencies of the two Sides of the Spectraphon. It lights Green for the simplest tuning ratios (octaves (2:1), fifths (3:2), and fourths (4:3)) and Red for the next simplest (major thirds (5:4) and sixths (6:5)). This indicator can be especially useful for “dual VCO” patches or when using tuned FM and/or Follow. (Note these are just ratios rather than equal temperament intervals).

A-In and **B-In** have a special function in SAO: they are frequency inputs for only the Even harmonics and do not affect the Odd harmonics. The inputs are normalised to a voltage offset, so that when unpatched the attenuators function as detune controls with a range of one octave. The inputs accept bipolar signals so they can be used for pitch sequencing of the Even harmonics, or as a secondary FM input.

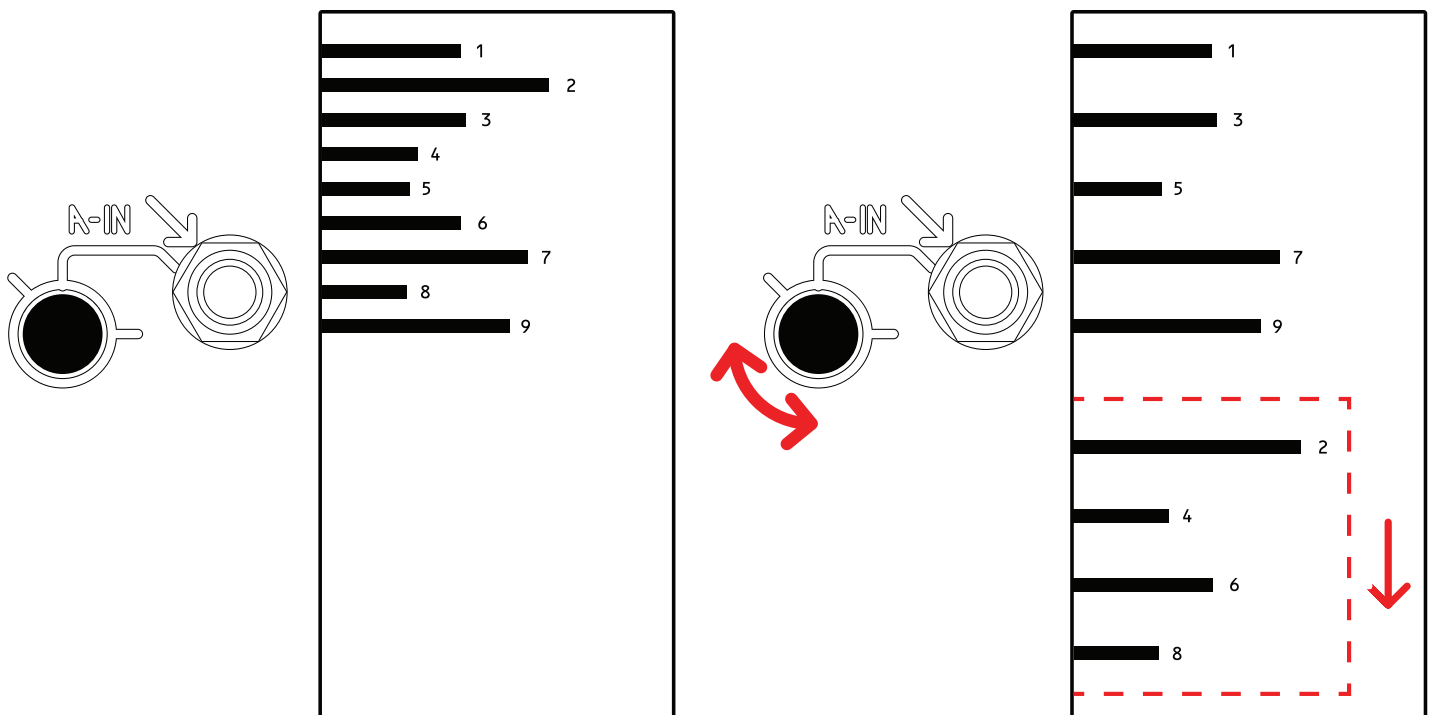

SPECTRAL AMPLITUDE MODULATION MODE (SAM)

When a Side of the Spectraphon is in SAM mode (SAM/SAO button is OFF), the incoming signal modulates the amplitude of individual harmonics of the Odd and Even outputs. The modulation depth is set by the A and B input attenuators, with visual tickmarks for typical “modular” and “line” level signals.

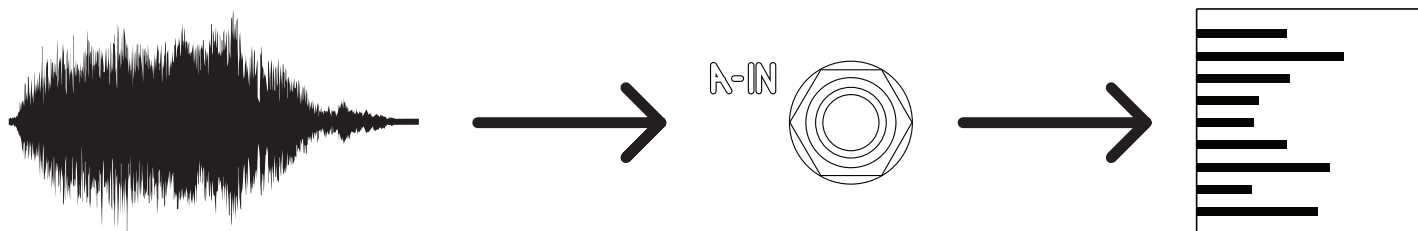

In this mode, Slide selects the fundamental frequency (first harmonic). The incoming signal will be analyzed in terms of its relation to this fundamental. Focus sets the width or sensitivity of each band (how close to a given harmonic the input must get in order for that harmonic to be activated). The resulting collection of harmonics, i.e. the spectrum, can be heard at the Odd and Even outputs. The relative setting of the fundamental set by Slide and the actual frequencies present in the input sound means that Slide can also be used to set the relative weight of upper and lower harmonics (if Slide selects a fundamental that is lower than that of the input sound, the lowest harmonics in the output will have less energy, resulting in a “brighter” sound).

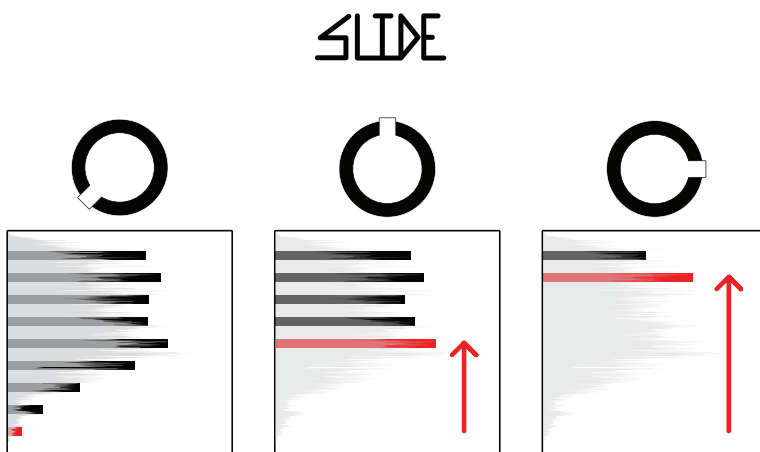

The Red line represents the First harmonic (aka fundamental frequency), as interpreted by Slide.

In practice, this means that the Slide control can be used to set which harmonics are emphasized. Slide works in tandem with Focus to shape the spectral content of the outgoing sound.



SPECTRAL AMPLITUDE MODULATION MODE (SAM)

The Focus control sets the size of the ranges of harmonics that will be activated by the Spectraphon. At low values, smaller ranges of frequencies will be heard and the individual harmonics will tend to be more pronounced and change in amplitude more quickly as the input sound changes or Slide is modulated. At higher values, more harmonics will be heard and they will tend to “ring” longer after changes in the sound source or in modulation to Slide. At the highest values, many harmonics are heard and they will have a noticeably sluggish response to change, creating droning effects and even something like “echo” at times.

The spectrum created by this spectral amplitude modulation appears at the Even/Odd outputs and is further affected by the Pitch, Partials, and FM controls as follows:

- The **Pitch** control sets the fundamental frequency from which the spectrum will be resynthesized at the even/odd output.
- The **Partials** control operates on the current spectrum by changing the amplitude of the individual harmonics.
- The **FM Index** control frequency modulates the harmonics of the spectrum using the core of the other Side of the Spectraphon (FM).

In **SAM** the **Pitch**, **FM**, and **Partials** controls all work the same way as in **SAO**, and can be sequenced and modulated much as you would one side of a dual voltage controlled oscillator. The only significant difference as regards these controls is that instead of oscillating at all times as a typical analog VCO does, the amplitude is modulated by an external signal. If the external signal contains a lot of dynamic motion, so will the harmonic outputs. If the external signal is a constant amplitude (another VCO, for example, or even the other side of the Spectraphon itself), then so will be the harmonic outputs.

In SAM the default output for Sub/CV is an envelope follower. This will output a positive control voltage representing the current amplitude of the sound at the input. It can be particularly useful when patched to Slide or Focus to add clarity, and can also be used to time any other modulation in your system to the sounds that you are using to modulate the Spectraphon.-

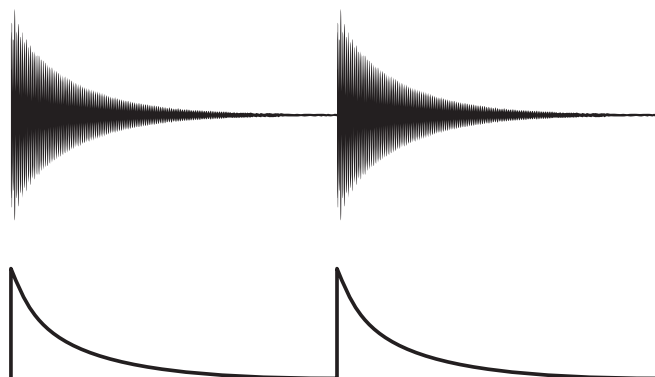

SPECTRAL ARRAY OSCILLATION MODE (SAO)

When a Side of the Spectraphon is in SAO (SAM/SAO button is On), instead of being spectrally amplitude modulated by the incoming signal, it reads from the currently selected Array and oscillates at the Odd and Even harmonic outputs based on the current spectrum within the Array.

In this mode, the Slide control dynamically selects which spectrum is currently being output at the Odd and Even outputs. Fully counterclockwise for the first spectrum in the Array, and fully clockwise for the last spectrum, taking a linear path from one end to the other.

The Focus control is used for spectral compression/expansion. Turning this control further clockwise creates spectral compression. What this means is that the loudest and quietest harmonics in the current spectrum are compressed so that they are closer to the same level. In many cases this will make the sound brighter, and even out the apparent loudness across the Array. This can be useful when using SAO as something like a traditional VCO.

Turning Focus down creates spectral expansion. What this means is that the loudest harmonics in the spectrum get even louder, while the quietest get even quieter. In many cases this will make the sound darker, and will also tend to accentuate differences when Slide is modulated, for example making transients stand out more.

Also available is an alternate “Planar” modulation style, accessible by holding the Side’s Shift button for 2 seconds without pressing any other buttons.

Note: Planar modulation is the default and only style available on firmware prior to sp67.

In this modulation style, the Slide and Focus controls dynamically select which spectrum is currently being output at the Odd and Even outputs. Focus can be thought of as a fine selection control, selecting a small portion of the Array, while Slide is more coarse, selecting through the whole range of spectra.

The Freq control and 1v/oct set the fundamental pitch. In-A and In-B can be used to detune the Even outputs, either using the attenuators to tune a slight detune for phase drift or a harmonic interval, or in a bipolar manner with the CV inputs. The inputs are normalized to a voltage for tuning Even outs to an interval relationship with the Odd outs. These inputs can alternatively be used as secondary FM inputs for the Even harmonics.



SPECTRAL ARRAY OSCILLATION MODE (SAO)

In SAO the Clock input will step gradually through the Array with each clock pulse.

Note: The result of clocking the Array is offset by the Focus and Slide controls: clocking the Array dynamically changes the "mapping" of the Slide and Focus controls, allowing all three to modulate simultaneously without canceling each other out.

Just as in SAM, the Partial control operates on the current spectrum by changing the amplitude of the individual harmonics.

Just as in SAM, the FM Index control frequency modulates the harmonics of the spectrum using the core of the other Side of the Spectraphon (FM).

In SAO the default output for Sub/CV is a sub-oscillator. On Side A, it is a Sub-Sawtooth, and on Side B, a Saturated Sub-Sine.

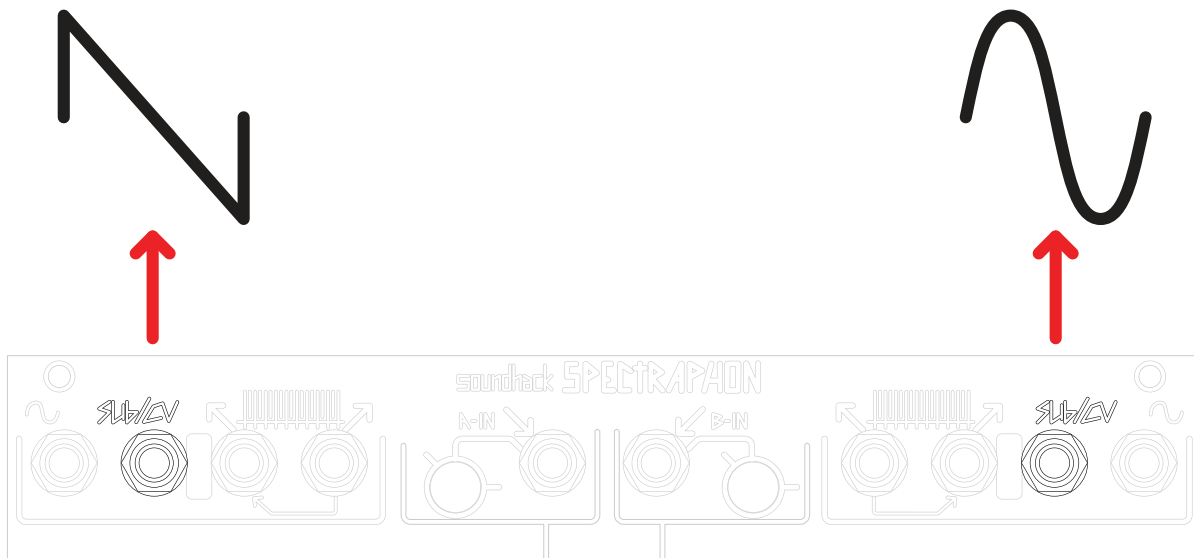

SELECTING ARRAYS

The Spectraphon can hold up to 16 Arrays per Side. To select, hold Shift on the side you are selecting for, and press the opposing Shift. The Array Binary shows the currently selected Array using the four colored LEDs to show a 4 bit binary number.

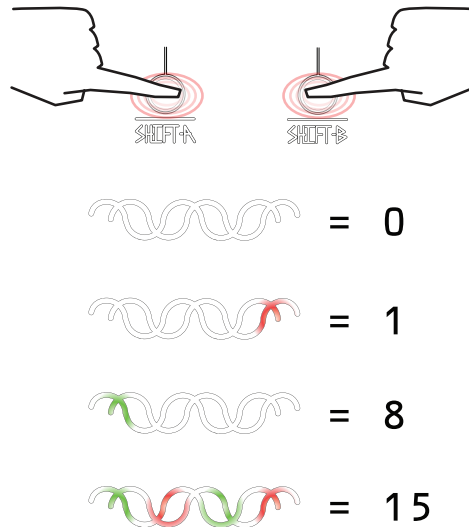

In SAO the currently selected Array will be used for the Odd and Even outputs, with the Slide and Focus controls selecting the spectrum to be output.

A new Spectraphon uses the same “default Array” in all 16 locations on both sides.

In SAM the currently selected Array is not used directly; instead it will be overwritten when creating a new Array. You can still select Arrays in SAM, so that you can write to multiple locations.

Created Arrays are saved on the microSD card with filenames indicating the Side and the Number as follows:

SPECA000.WAV
 SPECA001.WAV etc.
 SPECB000.WAV
 SPECB001.WAV etc.

Any slot that does not contain a user-created Array will load the default instead. Arrays may be deleted or backed up/restored by loading the card into a computer.

In firmware version sp38 or above, it is also possible to delete the Array and return to default by holding both SHIFT buttons. See "sp38 changelog" on p. 36 for additional info.



CREATING ARRAYS

In SAM, at any given time the output at the Even/Odd harmonic outputs as determined by the signal at the input and the Slide and Focus controls can be considered a spectrum. It is possible to use this spectrum (or better yet, a whole series of these spectra) to create an Array to be used in SAO mode.

To initiate Array creation when in SAM mode and with audio at the input, for best results, turn off the FM Bus and turn Partials full clockwise. Hold Shift for the side you are using, and press ARRAY.

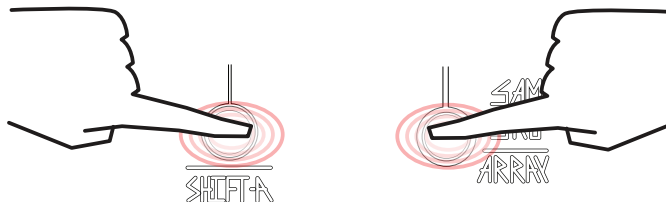

If no pulse has been received in the Clock input in the past three seconds, then the Array will be created automatically. The Spectraphon will write 1024 spectra into the Array over the course of slightly more than one second.

If a clock has recently (in the last three seconds) been received in the Clock input, then once Array creation has been initiated, a single spectrum will be written at the moment of each additional Clock. You can stop Array creation at any time by pressing [SHIFT+ARRAY] again, or it will automatically stop when the maximum number of spectra (1024) has been reached.

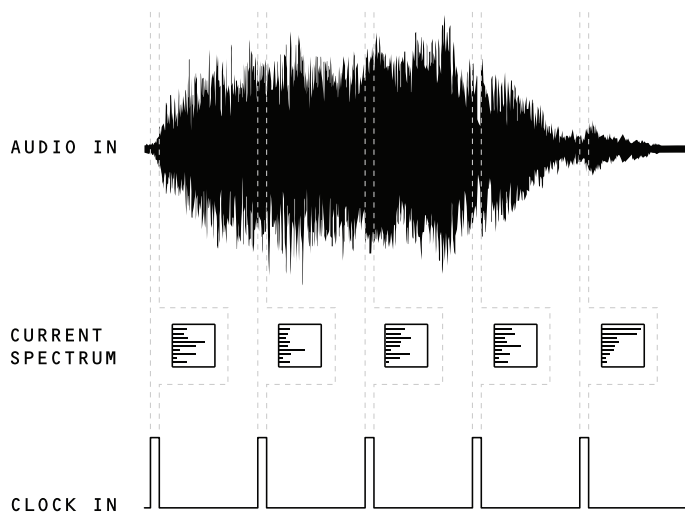

When you return to SAO after creating an Array, the Spectraphon will momentarily go silent as the new Array is written. The spectra of the currently selected Array will now be automatically mapped to the full range of the Slide and Focus controls. Note that the more spectra were captured, the more distinct locations will be found on these parameters. The Spectraphon automatically interpolates between values when fewer than the maximum are present.



TIPS FOR ARRAY CREATION

There is no prescribed “best practice” for creating Arrays. It is by nature a somewhat open-ended and experimental process that can lead to wildly varying results. That said, below is some information that could be useful in deciding when and how to create Arrays of spectra.

- It is important to note that Arrays are not sound recordings. Instead, each spectrum within the Array is a collection of values denoting the amplitude of each harmonic at the moment of its creation. The actual pitch of these harmonics at the output will be determined by the Pitch settings of the Spectraphon. Unlike sound recordings, spectra can be frequency modulated at high depth and resolution, oscillate at any pitch, have their odd and even harmonics operated on independently, and be dynamically scanned from one spectrum to the next, all with no change in sound quality.
- For best results, always create Arrays while the Partial control is turned all the way up (clockwise) and unmodulated. Arrays are normalized in amplitude after creation, based on the output levels of the Spectraphon as they are being created. Keeping Partial down during Array creation will give an inaccurate “preview” and could additionally result in clipping/oversaturation of the resulting Array when used in SAO.
- Any fast modulations, transient tails, “Focus ringing” and other fast smooth motions in the sound will usually be best represented by a fast clock rate, either by using the automatic (unlocked) Array creation, or by patching a fast external clock. After the Array is written and you have switched to SAO, you may hear traces of these motions in small modulations of the Focus control.
- By contrast, slower or stepped timbral modulations may benefit from slower clocks, or clocks that are synchronized with the timbral changes.
- In most cases, the best results for Array creation will be found during times when there is significant harmonic animation in the sound, whether that means a dynamic input signal, dynamic modulation of Slide and Focus, or some combination thereof. If the spectrum goes silent or remains static through part of the creation process, those characteristics will be inscribed in the result as “dead spots” in the Slide and Focus controls when using the Array in SAO. This can be put to many creative uses, but is also useful to be aware of.
- Most traditional VCO waveforms are stronger at the fundamental frequency than at any other harmonic. By contrast, it is possible to make Spectraphon Arrays that consist entirely of upper harmonics. This can be a fun thing to experiment with, and will also result in waves that may feel unfamiliar when using them in SAO. As with the above tip, this can be used creatively, and is good to be aware of.



MODULATION AND CLOCKING

The Slide and Focus parameters are the primary spectrum modulators: in SAM they select which harmonics are emphasized based on the input signal to create the spectrum, and in SAO they select the spectrum that is sent to the output. By default, in SAO the Clock input provides a way to switch from one spectrum to another immediately to create a linear “scan” through the full Array. The resulting selection is added to the values of Slide and Focus, so that all the controls can work well in tandem.

The Sub/CV output can also be used as a modulation source. Use [Shift+CV] to select between four different signals for this output:

1. Sub-Oscillator (SAO)/Envelope Follower (SAM)

(in sp38 or greater, SAM can also access the SubOscillator)



2. Stepped Random CV



3. Smooth Random CV



4. Triangle LFO



5. Ramp LFO



MODULATION AND CLOCKING

The CV output selection is per-side (Side A and Side B can be set independently with their respective Shift buttons).

If option 2, 3, or 4 is selected, the Clock input and Shift button become clock inputs for the selected CV type (they will no longer be used to step through the Array). When the clock input is not in use, the rate can also be set by tapping the Shift button ("tap tempo") with a minimum frequency of one clock every 3 seconds.

The Sub/CV output is represented visually on the panel by the Sub/CV Activity Windows.

In firmware version sp38 or above, the Sub-Oscillator is available in SAM as well as SAO. See "sp38 changelog" on page 37 for additional info.



SPECTRANOISE UPDATE

Starting with version sp52, the Spectraphon contains two additional oscillator modes. The Mode button LED and Array Binary are now used to display the current Mode per Side:

- SAM (Mode button OFF, Array Binary OFF)
- SAO (Mode button ON, Array Binary 00 i.e. OFF OFF)
- Noise (Mode button ON, Array Binary 01 i.e. OFF/RED)
- Chaos (Mode button ON, Array Binary 10 i.e. GREEN/OFF)

In Noise mode the Even and Odd outputs contain a pair of sine waves (use the Input attenuator to detune them up to an octave from each other). The Partial control sets the width of noise sidebands around the sine frequency. The Slide and Focus controls set the frequencies of a low-pass and high-pass filter, respectively, for this modulating noise, further shaping the sidebands. The most broadband Noise will be achieved with Partial and Slide fully clockwise while Focus is fully counterclockwise.

In Chaos mode the two sine oscillators are each paired with a second sine whose harmonic ratio to the core is set by the Focus control. (As with SAO and Noise you can use the Input attenuator to detune the two sines by up to an octave.) Partial adds audio rate modulation of one sine by the other, and Slide adds multiple chaotic feedback paths to this modulation.

All frequency controls work the same in Noise and Chaos as in all other modes. This includes the FM Bus.

This firmware also adds a "Low Frequency" behavior to SAO, Noise, and Chaos. To switch a Side into low frequency, hold Shift and press Array (this is the same process used for Array creation in SAM). Make your Spectraphon into a chaotic modulation powerhouse!

As always with Spectraphon there are two independent Sides. Each Side can run in its own mode; mix and match modes as you like! And of course the Sine and Sub/CV outputs, the FM Bus, Follow, and Sync, all work the same across modes.



TIPS AND TRICKS

- The two Sides of the Spectraphon can switch modes independently. This means there are many ways to let them interact. For example, when using one side in SAO, you can FM it with the other side even though the other Side is in SAM. One side will often make a good modulation source for the other, whether via FM in either mode, or spectral AM in SAM. Using both sides in SAM in series or parallel can lead to interesting layered results. If both sides are in SAM, you can do spectral AM in Stereo in interesting ways.
- Processing Odd and Even outputs of a single Side in parallel can be interesting. For example:
 - Send only the Even output through echo while the Odd remains “dry,” or send the two outputs through two different types of filter.
 - Try letting the Odd outputs drone at one pitch while sequencing the Even outputs using In-A/B.
 - Panning the two outputs slightly left and right of center and modulating Partials can create interesting stereo ripples as the Partials parameter alternates which harmonics it acts upon.
 - All this can be expanded upon by doing the same or different with the Even/Odd outputs from the opposing side.
- The Sine and Sub outputs can mix very well with their Sides’ harmonic outputs, as they are unaffected by other modulations and can provide a strong sense of fundamental Pitch even when the harmonics get extreme. The Sine output can also provide a convenient demonstration of the core frequency when tuning to match the sound at the input in SAM, or in SAO when using an Array that contains mostly upper harmonics.
- The Sub/CV outputs can be patched across Sides. While this sounds obvious, it can be easy to forget in the heat of patching. For example, with Side A in SAM, use its Sub/CV Envelope follower to modulate Slide in time with the incoming audio, while Side B’s Sub/CV provides Random modulation to Side A’s Focus or Partials.
- For a simple tuned FM patch, while sequencing Side A, turn on Follow at any time and adjust Side B Pitch until the Tuning Beacon turns Green. Turn up FM Index A or modulate it with triggered functions. As with many patches, this will work regardless of which modes the two Sides are in. Note: for tuned ratios using Follow, it will be best to turn on the Follow mode first, prior to tuning.
- The Partials parameter can double as a timbral VCA in a pinch, but don’t overlook the power of setting it to a mid-value and modulating it subtly up or down.
- High Partials and Pitch settings can lead to extremely high pitches in the output - sometimes a filter or low pass gate will do wonders for these sounds.



TIPS AND TRICKS

- All controls on the Spectraphon have been given very large ranges, making it very possible to go from subtle to extreme in a number of different ways. There is also attenuation and inversion on nearly every parameter, because in most cases modulating even very small portions of the parameter ranges can have dramatic effects. The high internal processing resolution of FM, Partials, Slide, and Focus are such that even one little corner of each can give great variety of results when patched thoughtfully.
- When switching from SAM to SAO, you will usually want to unpatch your sound source from the input, because in SAO the input and its panel control is used to change the frequency of the Even output - a very different sound from the spectral AM in the other mode!
- Patch a trigger source into the Input in SAM mode, and the Envelope Follower to Focus, for a triggerable voice.
- If you have created Arrays in all sixteen slots on both Sides, you can restore the default Array to any slot by deleting the respective file from the microSD Card.



APPENDIX: THE MICRO SD CARD

On the reverse of the Spectraphon is a MicroSD card that stores the Arrays used in SAO.

Created Arrays are saved on the microSD card with filenames indicating the Side and the Number as follows:

SPECA000.WAV
SPECA001.WAV etc.
SPECB000.WAV
SPECB001.WAV etc.

Any slot that does not contain a user-created Array will load the default instead. Arrays may be deleted or backed up/restored by loading the card into a computer.

The MicroSD card is also used for Spectraphon firmware updates.

To install firmware, look at the back of the Spectraphon where you will see a small cutout in the back board which provides access to a micro SD slot. Take the card out of there and load it up on your computer. Remove any existing sp_.dat files from the card (and empty the Trash), and replace with the new sp_.dat, then place the card back in the SD slot. Power up the Spectraphon while holding SAO/SAM B (the right-hand Mode button) to bootload the firmware.

The firmware version display utilizes the Array Binary (the four LEDs in the center of the module just under the SAO/SAM buttons) to display two four bit binary numbers during powerup. For example, for sp38 the version code is 0010 0110:

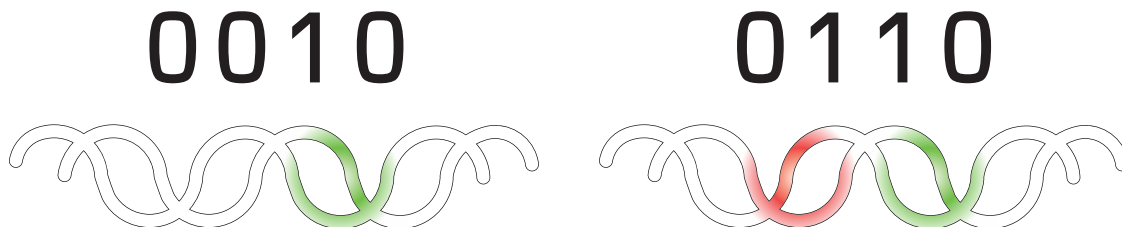

SP38 CHANGE LOG

New firmware version sp38 is available here:

https://www.makenoisemusic.com/manuals/sp38_firmware.zip

It adds the following features:

1. Sub-Oscillator is now available as a Sub/CV output mode in SAM (previously only available in SAO).
2. Adds option to Delete currently selected User Array and return to Default Array on current slot. To Delete, while holding SHIFT button on the Side whose User Array you are Deleting, press and hold opposing SHIFT button for 2 seconds. For example to delete current Array on Side A, Hold SHIFT-A first, then Hold SHIFT-B for two seconds.
3. Fixes a critical bug wherein it is possible to accidentally erase calibration for panel controls and/or v/oct scaling.
4. Minor bug fixes

If your Spectraphon has a serial number of #1760 or higher, you do NOT need this update.

Check the Array Binary during power for correct sequence. SP38: 0010 0110

0010

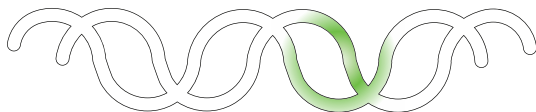

0110

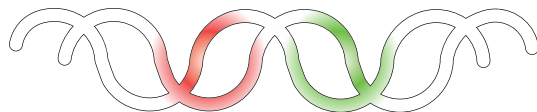

If your Spectraphon already powers up with this sequence you do not need this update.

Video installation instructions and feature demonstration at <https://youtu.be/rtbrprF3Jkc>



SP52 CHANGE LOG

New firmware version sp52 adds the following features:

1. Two new Oscillator modes: Noise, and Chaos!

In Noise mode, the Even and Odd outputs contain a pair of sine waves (use the Input attenuator to detune them up to an octave from each other). The Partial control sets the width of noise sidebands around the sine frequency. The Slide and Focus controls set the frequencies of a low-pass and high-pass filter, respectively, for this modulating noise, further shaping the sidebands.

In Chaos mode, the two sine oscillators are each paired with a second sine whose harmonic ratio to the core is set by the Focus control. (As with SAO and Noise you can use the Input attenuator to detune the two sines by up to an octave.) Partial adds audio rate modulation of one sine by the other, and Slide adds multiple chaotic feedback paths to this modulation.

2. Low Frequency behavior added to all "oscillator" modes (SAO, Noise, and Chaos). To switch a Side into low frequency, hold Shift and press Array (this is the same process used for Array creation in SAM). The SHIFT button stays lit to indicate the Side is in Low Frequency.

3. All Mode options reset to factory settings when powering on while holding SHIFT A & SHIFT B.

4. Improved low frequency compensation for Partial parameter in SAO.

5. Minor bug fixes

If your Spectraphon has a serial number of #1909 or higher, you do NOT need this update. Check the Array Binary during power for correct sequence. SP52: 0011 0100

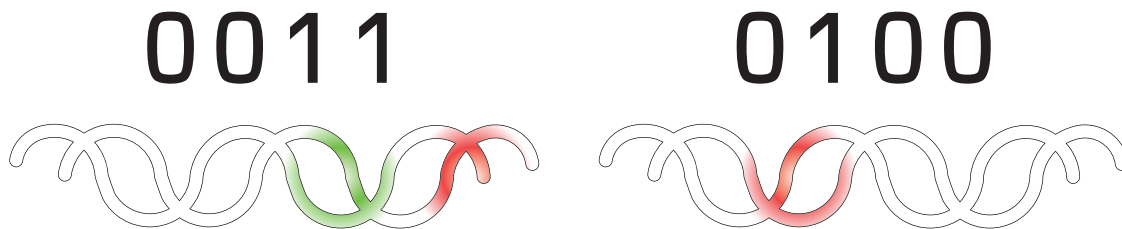

If your Spectraphon already powers up with this sequence you do not need this update.

Sounds and examples can be found in the SpectraNoise YouTube playlist:

https://www.youtube.com/playlist?list=PL0jGFC0FWQsilQKxfjS51oFWdAs_pmhgB



SP67 CHANGE LOG

New firmware version sp67 is available here: <https://www.makenoisemusic.com/firmware>

It adds the following features:

1. Linear Array Modulation! In SAO, the Slide parameter now selects from all spectra in the Array in a linear fashion. The Focus control is used for spectral compression/expansion.

The original Planar Modulation style is still available. To access, while in SAO hold SHIFT for 2 seconds without pressing any other buttons. This operation is per-Side.

2. New Ramp LFO Shape on Sub/CV Outputs. Select shapes by hold Shift + Press CV on the Side you're selecting for. Ramp is useful for Linear Array Modulation (patch to Slide with attenuverter set north of midnight) and plenty of other uses.

3. CV output LFOs' minimum clock rate increased to 8 seconds, via tap tempo on Shift button, or clock input.

If your Spectraphon has a serial number of #2222 or higher, you do NOT need this update.

Check the Array Binary during power for correct sequence. SP67: 0100 0011

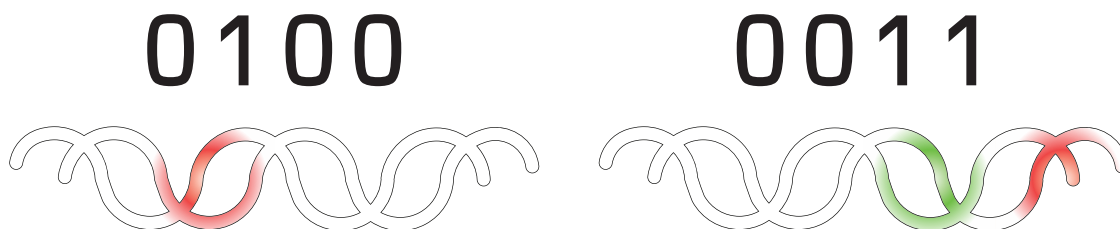

If your Spectraphon already powers up with this sequence you do not need this update.

For a brief demonstration of these new features see the YouTube video here: <https://youtu.be/LJa6eeNwJu4>

