

User Manual V1.3.0

Introduction

Gloop is an experimental eurorack looper. It allows you to record loops (with overdub), and playback with 4 simultaneous play heads. Each play head can be at a different part of the loop, playing at a different speed/pitch, direction and volume. Each play head can also be playing a different area, or sub-loop of the main loop. This can allow you to trim the loop size, play different sections of the main loop with the different play heads or create granular style effects.

All 4 play heads are constantly playing, but only the 'Active Play Head' can be modified by the panel controls. The playheads can be combined into a single mix and routed to two separate channels, A and B.

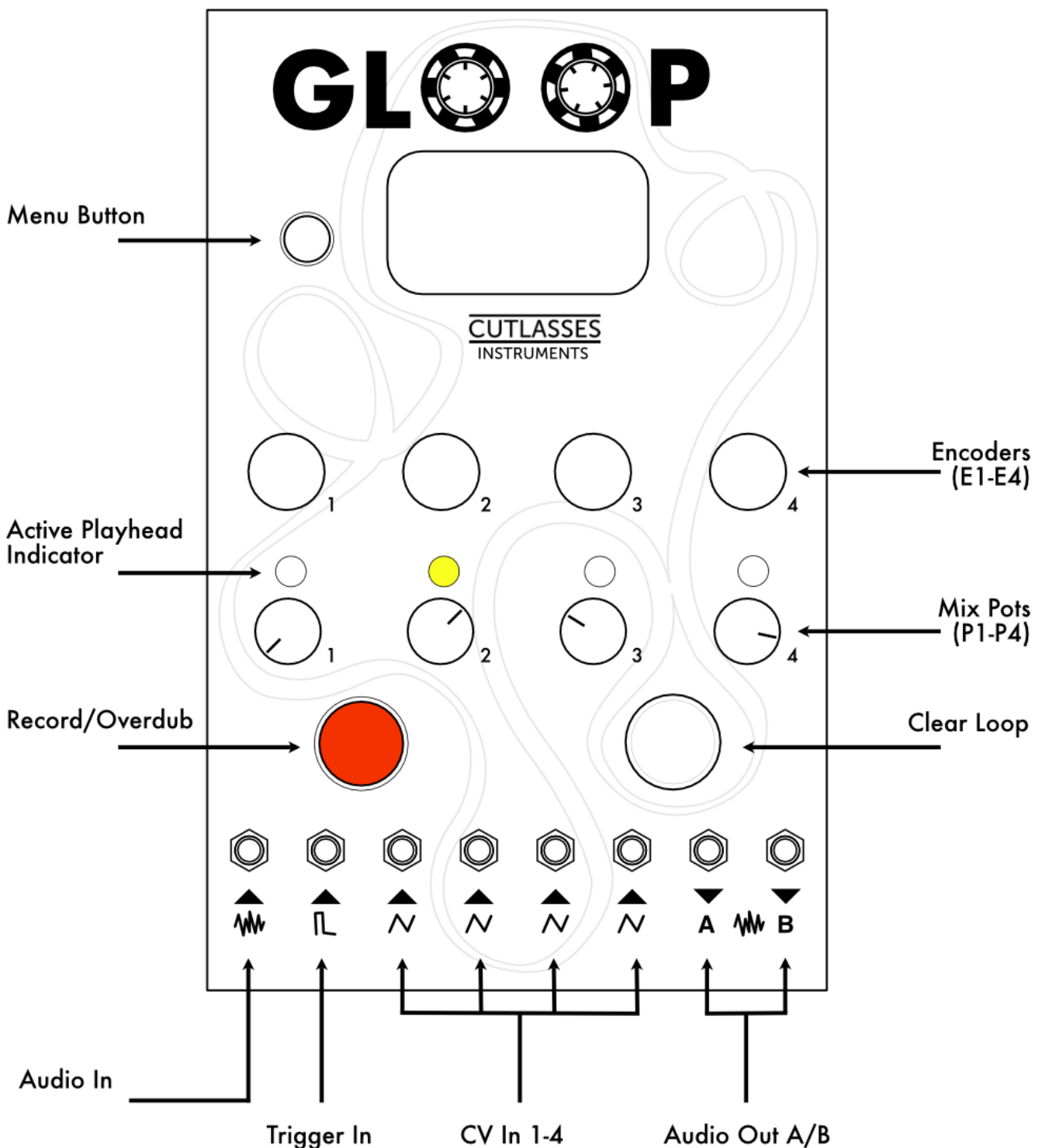

Technical Specs

Current draw - +12V 165mA, -12V 35mA Max

CV inputs - -5V to 5V (larger signals will be clamped)

Trigger input - >3V required to trigger

Audio: 48Khz 24-bit digital audio, 2 minute maximum loop length

Controls

Menu Button

Press to cycle through menus, see *Menus*.

Encoders 1-4

Each encoder has a switch so can be turned and clicked. The purpose of the encoders changes depending on which screen you are in.

Potentiometers 1-4

The potentiometers, or 'pots', are used to adjust the volume of each play head.

Record/Overdub Button

Press once to start recording and press again to end the loop. If overdub is enabled, subsequent presses of the button will start and stop overdubbing. The screen will flash when recording.

Clear Loop Button

Hold for 2 seconds to clear the current loop. Holding down for a further 2 seconds (4 second hold) will reset the loop position, loop size, and playback speed of all playheads.

Audio In

Connect audio to the module. Gloop cannot generate sound without having audio input.

Trigger Input

The trigger input is equivalent to pressing the record button. Use a trigger voltage to get the start and end points in time.

CV In 1-4

Connect CV to modulate Gloop. See *CV Targets* for details on how to configure it.

Audio Out A/B

Two channels of audio out. Play heads can output to either of these, or to both, or panned in between.

Quick Start

Before you dig into the details of Gloop's functionality you might just want to start patching and playing. One of the defining elements of Gloop is its multiple play heads, so let's get started by learning how to play with them.

1. Turn all pots fully anti-clockwise (muting all play heads).
2. Plug in a modular level audio source into Audio In.
3. Connect Audio Out A to your system output.
4. To start recording the loop, press the red button, to end recording, press it again.
5. The waveform of the loop will appear on the screen.
6. Turn the first pot clockwise and you will hear the recorded loop.
7. Rotate Encoder 2, this will reduce the size of active loop. You will see the > > loop indicators move inwards.
8. Rotate Encoder 1, this will change the position of the loop. You will see and hear Gloop playing a smaller sub-section of the original loop.
9. Rotate Encoder 4, you will hear the pitch of the loop change.
10. Press Encoder 1 to change the active play head. You will see [H1] change to [H2], indicating you are now controlling play head 2.
11. Rotate Pot 2 clockwise, you will hear play head 2 mixed with play head 1.
12. You can now blend together all of the play heads, by pressing Encoder 1 to cycle through the play heads, and mixing them together with the pots. Experiment with changing the size, position, and pitch of each loop.

Main Screen

This is the screen you will see when you start up Gloop. This is where you will see the waveform of the recorded loop and edit the sub-loop sections for every play head.

The writing in [] from left to right correspond to the 4 encoders left to right

[H1] - active head - press Encoder 1 to cycle through the play heads

[N] - Normal sensitivity - press Encoder 2 to toggle between Normal and Fine
[F]

[JO] - This is level of Jitter from 0-9. Jitter controls how much the loop moves each time it restarts. From 0, no movement, to 9, maximum movement.

[1.0x] - This is the current playback speed for the active head. Turn the Encoder 4 to change the speed. Press Encoder 4 to toggle between adjusting speed/pitch as a ratio, and adjusting pitch in semitones.



The >> represent the current loop area. This is the sub-loop of audio being played by the active head. It can range from the entire recorded loop, to a tiny granular size portion. When a loop is playing you will see a line moving across the loop, this is the position of the playhead.

If you look closely at the centre of the waveform you will see a single dot moving across the centre, this is the position of the write head. The write head is where overdubs will start recording.

Encoder	Rotate	Press
Encoder 1	Move play head from left to right	Cycle through play heads
Encoder 2	Change size of loop segment	Cycle sensitivity Normal/Fine
Encoder 3	Adjust Jitter amount	Toggle direction of playback Forward/Reverse
Encoder 4	Change Speed	Toggle Speed type Ratio/Semitones

Menus

Using the menu button you can cycle through each of the menus until you get back to the main screen. To jump back to the main screen without cycling through the remaining menus you can hold down the menu button for 1 second.

Each menu contains a number of options which are modified using the 4 encoders. Dials and text selection boxes are changed by rotating the pots, check boxes are toggled by pressing the encoder. For menus with 4 options, these map directly to the encoders 1-4, for menus with less option, the far right encoders are not used.

TIP: For text selection boxes (such as CV Target), you can press the encoder to reset the selection to the first option.

Effects 1

TIME - Delay time of the delay effect - from 5 milliseconds to 0.5 seconds

FEED - Delay feedback

MIX - Mix of delay

RVB - Level of reverb



Effects 2

BCDE - Bit Crush - bit depth from 1 bit to 32 bit

BCRA - Bit Crush - sample rate divider

BCMO - This allows you to select where you want to position the bit crusher in the effects chain. Use the encoder to cycle through the modes. The bit crusher can be inserted before or after the reverb, and additionally into the Degrade path (see 'Effects 3'). This allows you to choose from bit crushing the reverb tails to make them sizzle, or soften the bit crush by applying reverb to it. By applying reverb in the Degrade path your loop can slowly fizzle away.

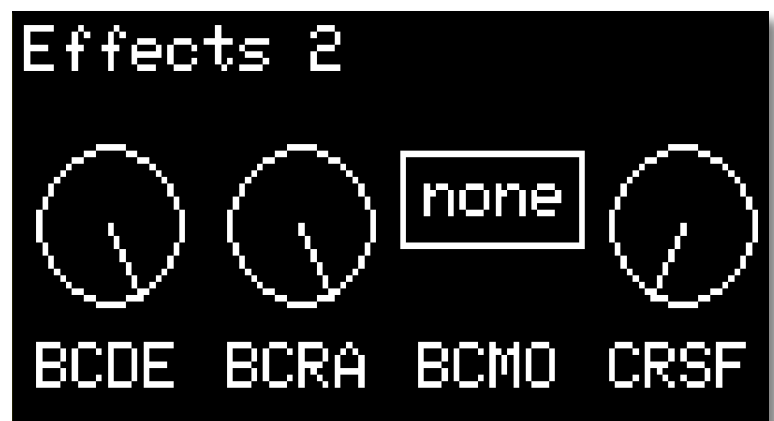

Bit Crusher Mode	Description
none	Bit Crusher disabled
pre	Inserted BEFORE the Reverb
post	Inserted AFTER the Reverb
degr	Inserted into the Degrade path
pred	Inserted BEFORE the Reverb AND inserted into the Degrade path
pose	Inserted AFTER the Reverb AND inserted into the Degrade path

CRSF - Crossfade time. Each time a loop section cycles, a cross fade is applied between the end and the beginning so that the transition is smooth. This dial allows you to adjust the crossfade time from 5 milliseconds up to 1 second.

Effects 3

IN A - The volume of the incoming audio sent to Output A

IN B - The volume of the incoming audio sent to Output B

MEFF - Select whether the mono effects (delay and reverb only) are applied to Output A or Output B - rotate the encoder to select.

DEGR - With every repeat of the loop it will become progressively quieter and the high-end will be rolled off. The further the dial is rotated clockwise the stronger the effect. This allows you to do Sound on Sound technique, leave Gloop overdubbing and add new parts as the olds parts slowly drift away.

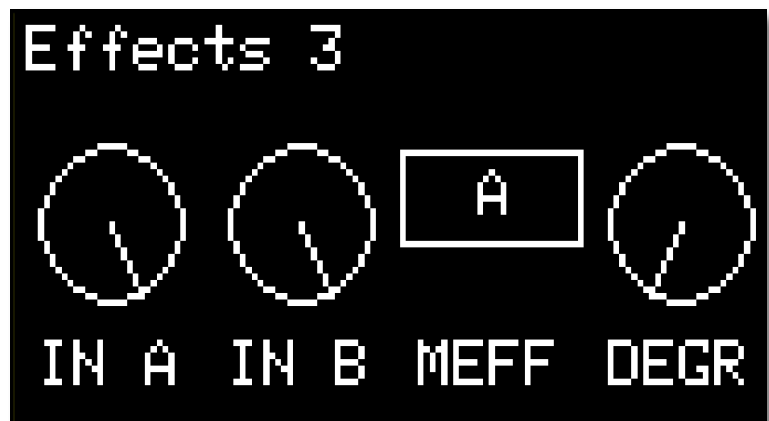

Tape

WOBB - Randomly changing wow and flutter frequencies modulate the pitches of all heads

SAT - Tape style saturation

HISS - Adds tape hiss with a gently modulated frequency range

AGE - Creates random drop-outs to simulate an old and deteriorated tape where the magnetic surface of the tape is deteriorating.

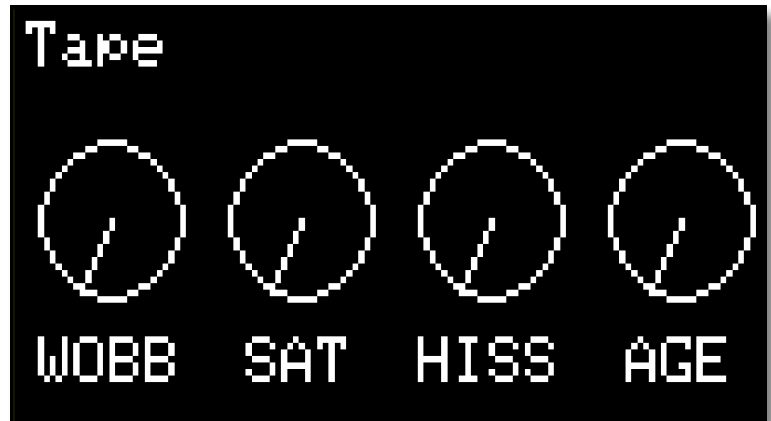

Wavefold

MODE - Allows you place the Wave Folding effect either before the reverb or after

TYPE - Type of wave fold algorithm, sine or triangle wave based.

GAIN - Amount of gain to apply to the input signal, from 1x to 15x

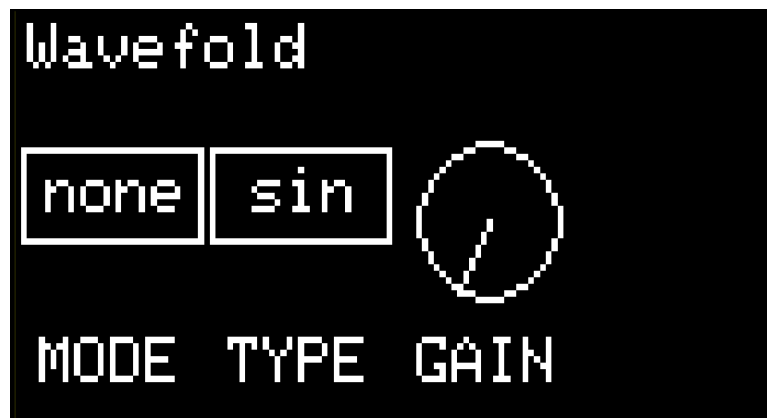

Wavefold Mode	Description
none	Wave folding is disabled
pre	Apply wave fold effect BEFORE reverb
post	Apply wave fold effect AFTER reverb

Wavefold Type	Description
sin	Sine wave wave fold algorithm
tri	Triangle wave wave fold algorithm

Outputs

Each head can be panned (with equal power) between outputs A and B. Fully anti-clockwise will output only to A, fully clockwise will output only to B. Having the dial at 12 o'clock will output to both A and B equally. The effects can only be applied to A or B (due to them being mono effects), so if you are panning a play head (rather than outputting to A or B) you may want to disable effects.

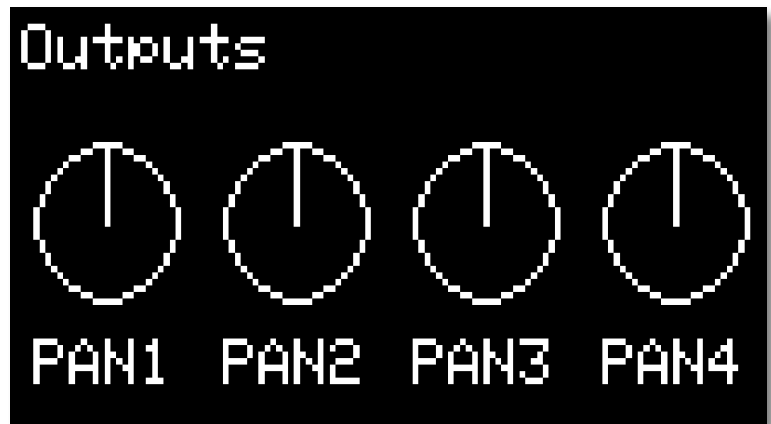

CV Targets

Each of the 4 CV inputs can be assigned to modulate one of a set of parameters. Rotate the encoder to select.

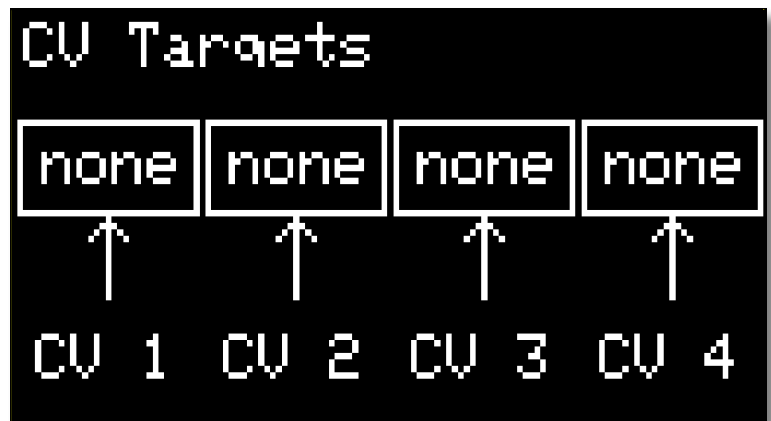

Modulation Target	Description
vol1-vol4	Volume of head 1-4
volA	Volume of ALL heads
spd1-spd4	Speed of head 1-4
spdA	Speed of ALL heads
pos1-pos4	Position (centre) of head 1-4
posA	Position (centre) of ALL heads
szel-sze4	Size of head 1-4
szeA	Adjust size of ALL heads

stl1-stl4	Start loop of head 1-4 - This expects a trigger pulse, when triggered the selected head will snap to the beginning of the loop. Play back will then loop as normal.
stlA	Start loop of ALL heads
sto1-sto4	One shot triggering of selected head - Loop will play once, when triggered, then playback will stop
stoA	One shot trigger ALL heads
jmp1-jmp4	Every time the voltage of this CV changes, jump the selected play head to a quantised position in the loop based on the positive voltage
pan1-pan2	Modulate the pan of heads 1-4. This modulation is shown on the pan menu as a dotted line.

CV Attenuation

Each dial corresponds to the attenuation of CV 1-4. Attenuating from max (original input level), to min, CV is completely zeroed. Bear in mind this attenuation is digital, and CV above +/-5V will be clipped before it gets to the module.

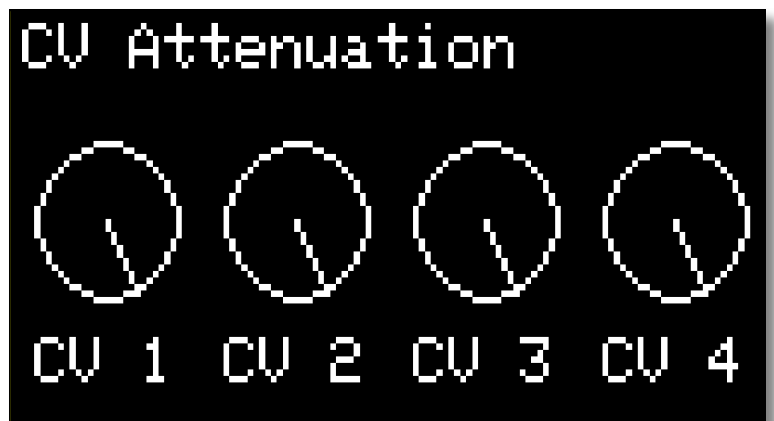

CV Misc

OFFS - This will offset all CV inputs. This is used to turn a 0V-5V DC input CV into an AC signal (centred on 0). Useful if you want to modulate something up and down but only have a positive modulation source. With this enabled a voltage of 0v will be interpreted as -5V, and a voltage of 5V will be interpreted as 5V.

WRTE - Set the write mode. This allows you to enable or disable Overdub. Sometimes it's useful to disable overdub if you are using the trigger to start/stop recording, and want to ignore subsequent triggers after the initial loop is recorded. You can also set the write mode to replace the audio that exists in the buffer.

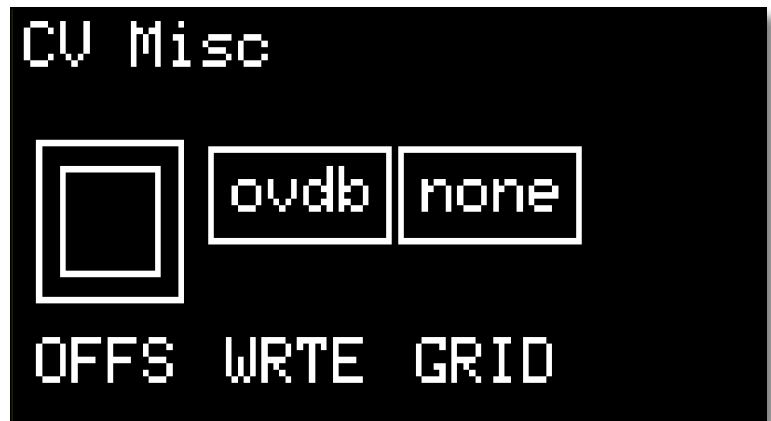

Write Mode	Description
none	Writing disabled, any presses of the record button, or triggering of record will be ignored.
ovdb	Mix incoming audio into the recorded loop
repl	Replace the existing audio in the buffer with the incoming audio

GRID - Enables the grid, at 4, 8 or 16 regions. With grid enabled all loop positions and sizes are clamped\quantised to the grid. Works great with rhythmic loops. Grid is displayed on main screen.

When setting playback speed using CV

1. If you want V/Oct, you must be in Semitone view, and should have CV attenuation set to no attenuation (fully clockwise).
2. If you are in ratio view (i.e. not Semitone), the CV modulation is *not* scaled to V/Oct, it's just intended as a way to modulate speed (for warping the sound). Maximum CV results in maximum speed adjustment (x10).

Troubleshooting

The loop seems to fade away are recording - it sounds like you have loop degradation active. To disable this, set DEGR to 0 (fully anti-clockwise).

The audio appears to be dropping out/cutting in and out - do you have the AGE setting in the TAPE menu set to a non-zero value? Try turning the dial fully anti-clockwise.

I can't hear any sound from the audio in - are 'In A' and 'In B' set to a value above 0?

I can't hear audio from the play heads - is the play head in question panned into the output you are monitoring?

I can't record anything/the Record button isn't working - Check that you haven't disabled recording. In CV Misc there is a setting called WRT, check this is not set to "none". When set to "none" recording is completely disabled.

Delay and Reverb don't appear to work - these effects are mono and can only be applied to a single channel, check MEFF is set correctly. See "Effects 3" above.

Updating Gloop

Updating Firmware

To update Gloop firmware, you need a USB micro-B cable and a firmware .bin file, follow these steps

1. Connect the Daisy Seed to your PC/Mac using the micro-B cable
2. Go to <https://flash.daisy.audio/using Chrome>
3. Ensure 'File Upload' tab is selected
4. Click 'CHOOSE FILE' and navigate to the firmware .bin file
5. Click 'FLASH'
6. Hold the BOOT button down on the Daisy Seed, and then press and release the RESET button (this allows the Seed to be programmed via USB)
7. The Daisy should appear in the window
8. Click 'Connect' and the firmware should start to flash

Calibrating

If you have an assembled Gloop it shouldn't need to be calibrated. This is only required for DIY builds, or if you are not getting good Volts Per Octave tracking when adjusting pitch. To calibrate you will need access to an accurate voltage reference that can output 1 Volt and 3 Volts. All 4 CV inputs are calibrated at the same time, so you must provide the correct voltages to all inputs simultaneously. You may want to use a mult module to do this (i.e to apply the same calibrating voltage to all CV inputs).

To calibrate, hold down the menu button when Gloop is first powered up. Follow the instructions on screen. Running a calibration will save new values to the Gloop's internal memory which will persist until you calibrate again. If you enter the calibration screen inadvertently you can leave by pressing 'Clear Loop' button.

Disclaimer

Product Use and Safety Notice

This product is designed for use in eurorack modular synthesiser systems by experienced users. It is sold "as-is" and may not comply with specific regulatory standards or certifications (e.g., CE, RoHS, FCC) required in certain regions. By purchasing or using this product, you agree to the following terms:

1. Usage at Your Own Risk

This module is provided without any express or implied warranties, including but not limited to warranties of merchantability or fitness for a particular purpose. The buyer or user assumes all risks and responsibilities associated with the installation, operation, and maintenance of this product.

2. Regulatory Compliance

This product may not meet the regulatory standards or certification requirements in your country, such as electrical safety, electromagnetic compatibility (EMC), or environmental directives. It is the buyer's responsibility to ensure compliance with local laws and regulations regarding the import, installation, and operation of electronic devices.

3. Electrical Safety

While we rigorously test our products for quality and reliability, this module has not been independently certified for safety in sensitive or high-risk environments. Always verify power requirements and ensure your Eurorack system is properly grounded and functioning correctly to avoid electrical hazards.

4. Warranty and Liability

This product is sold without any formal warranty. The manufacturer and seller disclaim all liability for any damages or losses resulting from the use or inability to use this product, including but not limited to:

- Damage to other equipment in your system
- Incidental, consequential, or indirect damages
- Injuries caused by misuse or improper installation
- Any modifications to the module may void eligibility for returns, repairs, or support.

5. Shipping and Import Responsibility

Buyers are responsible for all shipping, customs duties, taxes, or import fees applicable in their country. The seller is not liable for delays, rejections, or seizures by customs or regulatory authorities.

6. Return and Repair Policy

We are committed to ensuring the functionality of our products. If your module malfunctions due to manufacturing defects, we will make every reasonable effort to repair it. Please note the following:

- Repairs are offered for malfunctions that are not the result of wear and tear, misuse, or unauthorised modifications.

- Return requests are subject to standard rules and must be initiated within 14 days of receiving the product.

Buyers are responsible for shipping costs associated with returns or repairs, unless the issue is confirmed to be a manufacturing defect. For further details, please contact us directly.

Important Note

By purchasing or using this product, you acknowledge that you have read, understood, and agreed to the terms of this disclaimer. If you do not accept these terms, please do not proceed with purchasing or using this product.