



MANUALONE

A Single, Comprehensive Guide to Frap Tools' Modules

I'd like to thank a few precious friends for their support during these years, for the discussions we had, and for the valuable feedback i received — in alphabetical order: Tina Aspiala, Caterina Barbieri, Sebastian Baumann, Alessandro Bonino, Marco Ciccotti, Enrico Cosimi, Lorenzo Florissi, Tom Hall, Adam Heathcott, René Margraff, Gianfranco Marongiu, Chris Meyer, Jeff Nantais, Giulio Saltini, Alessio Santini, Stephan Schmitt, Brian Smith, Trevor Tunnacliffe, Giona Vinti, Andreas Zhukovsky.

And thanks to the amazing people I'm working with — in alphabetical order: Fabrizio Benatti, Federico Foglia, Giovanni Grandi, Antonio Masiero.

Simone Fabbri

TABLE OF CONTENTS

TABLE OF CONTENTS.....	3		
SAFETY AND WARRANTY.....	7		
BEFORE STARTING.....	8		
1	8		
2	8		
3	8		
MODULAR SYNTHESIS: CORE CONCEPTS.....	9		
1	9		
2	9		
3	9		
4	10		
5	10		
6	10		
7	11		
8	12		
8.1	12		
8.2	13		
8.3	13		
9	14		
10	15		
10.1	15		
10.2	15		
11	16		
11.1	16		
11.2	17		
12	17		
13	18		
SUGGESTED READINGS.....	19		
INTERFACES.....	20		
1	20		
2	20		
3	20		
4	21		
5	21		
CGM – CREATIVE MIXER SERIES.....	22		
1	23		
2	24		
2.1	24		
2.1.1	24		
2.2	24		
2.2.1	25		
3	26		
3.1	26		
3.1.1	26		
3.1.2	26		
3.1.3	26		
3.1.4	26		
3.1.5	26		
3.2	26		
3.3	27		
3.3.1	27		
3.3.1.1	27		
3.4	27		
3.4.1	27		
3.4.2	27		
3.4.3	27		
4	28		
4.1	28		
4.1.1	28		
4.2	28		
4.3	28		
4.3.1	28		
4.3.2	29		
4.4	29		
4.4.1	29		
4.4.2	29		
4.4.3	29		
5	30		
5.1	30		
5.2	30		
5.3	30		
5.4	30		
6	31		
6.1	31		
6.2	31		
6.2.1	31		
6.2.2	31		
6.3	31		
6.3.1	31		
(DISCONTINUED)	31		
6.4	32		
6.4.1	32		
6.4.2	32		
6.4.3	32		
7	33		
7.1	33		
7.2	33		
7.2.1	33		
7.2.2	33		
7.2.3	33		
7.2.4	34		
7.2.5	34		
7.3	34		
7.3.1	34		
7.3.2	34		
7.3.3	34		
7.4	34		
8	36		
8.1	36		
8.1.1	36		
8.1.2	36		
8.1.3	36		
8.2	36		
8.2.1	36		
8.2.2	36		
9	38		
9.1	38		
9.2	38		
9.3	38		
10	39		
10.1	39		
10.2	41		
SAPÈL.....	43		
1	43		

2	Noise Outputs.....	44	3.2.1	Amplitude Modulation & Ring Modulation (2 vs 4 quadrants).....	63
3	Voltage Sampling.....	44	3.2.2	Trimming.....	63
3.1	Internal Clock and Clock Modulation.....	44	3.3	Linear Slew Limiter.....	64
3.2	External Clock.....	44	4	Technical Data.....	64
3.3	Clock Mix.....	44	4.1	Revisions.....	64
3.4	Manual Sampling.....	45	4.2	Specifications.....	65
3.5	External Gate Sampling.....	45	USTA.....	66	
3.6	Clock Outputs (Main and Random).....	45	1	Quick start.....	66
4	Random Voltages.....	45	2	Philosophy And Design.....	67
4.1	Non-Quantized Random Voltages.....	45	2.1	Architecture.....	67
4.2	Quantized Random Voltages.....	45	2.2	Tempo Management.....	67
4.3	Fluctuating Random Output and Global Rate of Change (random clock density control).....	46	3	Basic Editing and Visual Feedback.....	68
5	Probability Distribution (Stored Random Voltages).....	47	3.1	Editing Projects – Project Menu.....	68
6	Technical Data.....	48	3.2	Editing Tracks – Track Menu.....	69
6.1	Revisions.....	48	3.2.1	Clock Settings.....	69
6.2	Flow Chart.....	48	3.3	Editing, Playing, and Looping Patterns.....	70
6.3	Specifications.....	49	3.4	Editing Stages.....	70
FUMANA.....	50		3.4.1	Length.....	71
1	Philosophy and Design.....	50	3.4.1.1	Maintain Pattern Length on Variation.....	71
1.1	Spectral Transfer: A Brief History.....	51	3.4.2	CV Layers.....	72
1.2	Panel Overview.....	51	3.4.2.1	Red CV Layer: Value.....	72
2	Audio Inputs.....	51	3.4.2.2	Green CV Layer: Variation Index.....	72
3	Audio Outputs.....	52	3.4.2.3	Blue CV Layer: Variation Range.....	73
4	Audio Processing and Modulation Path.....	52	3.4.3	CV Stage Colors.....	73
4.1	Faders and CV.....	52	3.4.3.1	USTA Slide vs FALISTRISlew.....	74
4.2	Macro Spectral Editing.....	53	3.4.4	Gate Layers.....	74
4.2.1	Tilt.....	53	3.4.4.1	Red Gate Layer: Value.....	74
4.2.2	Parametric Scanning.....	53	3.4.4.2	Green Gate Layer: Variation Index.....	74
4.3	Spectral Transferring: Modulation Filters and Envelope Followers.....	53	3.4.4.3	Blue Gate Layer – Variation Range.....	74
4.4	The 'Unvoiced' Section.....	54	3.4.5	Gate Stage Colors.....	75
5	Filter Design.....	55	3.4.5.1	Setting the Ratcheting Gate Width.....	75
6	Patch Examples.....	55	4	Quick Editing.....	76
6.1	16-Band Spectral Transfer.....	55	4.1	Set All and Shift All.....	76
6.2	Dual 8-Band Spectral Transfer.....	56	4.2	Coarse and Fine.....	76
6.3	Hybrid Spectral Transfer.....	56	4.3	Combining the Buttons.....	77
6.4	Vocoder-Like Behavior.....	56	5	Performing.....	77
7	Technical Data.....	56	5.1	Play/Pause, Reset, and Master Track Settings	77
7.1	Transfer Function.....	56	5.1.1	Master Track.....	77
7.2	Specifications.....	57	5.1.2	Play/Pause.....	77
FALISTRIS.....	58		5.1.3	Reset.....	77
1	Philosophy and Design.....	58	5.2	Stage Loop.....	78
2	Function Generators.....	58	5.2.1	Infinite Stage Loop.....	78
2.1	Analog Outputs (Envelope, LFO, Oscillator).....	59	5.3	Song Mode.....	79
2.2	Triggers and Modes.....	59	5.3.1	Pattern to Song While Playing (and vice versa)	80
2.2.1	Green Alternative Retrigger (On Rest).....	60	5.4	Live Performance Tools: Pattern Recall.....	80
2.3	Times.....	60	5.4.1	Full pattern recall.....	81
2.4	Shapes.....	60	5.4.2	Pattern Mix.....	81
2.5	Digital Outputs (Gates).....	61	5.5	Mute.....	81
2.5.1	End of Rise (EOR).....	61	5.5.1	Mute Track.....	81
2.5.2	End of Fall (EOF).....	61	5.5.2	Mute Channel.....	81
2.6	Additional Generator Features.....	61	5.6	Hold.....	82
2.6.1	Quadrature.....	61	6	Advanced Editing.....	82
2.6.2	Max.....	62	6.1	Composition Mode.....	82
2.6.2.1	ADSR.....	62	6.2	Use an External CV/Gate Keyboard.....	82
3	Function Processors.....	62	6.3	Store Pattern: Last Played or Last Full.....	83
3.1	Dual Cascaded Frequency Divider.....	62	6.4	Rotate Pattern.....	83
3.2	Four-Quadrant Multiplier.....	63	6.5	Cloning.....	83
			6.5.1	Clone a Stage.....	83
			6.5.2	Clone a Structure.....	84
			6.5.2.1	Clone a Layer.....	84

6.5.2.2	Layer Cross-Cloning.....	84	3	Timbre.....	112
6.5.2.3	Clone a Pattern.....	84	3.1	Triangle Shaper.....	113
6.5.2.4	Clone a Track.....	85	3.2	Pulse Shaper.....	113
6.6	Quick Track Initialization.....	85	3.2.1	Pulse-Width Modulation (PWM).....	113
6.7	Quick Song Initialization.....	85	3.2.2	Waveshaper.....	113
7	External Controls.....	85	3.3	Wavefolder.....	114
7.1	Clock Input.....	85	3.3.1	Sources.....	114
7.2	Auxiliary Trigger/Gate Input.....	86	3.3.2	Folding.....	114
7.2.1	Reset.....	86	3.3.3	Symmetry.....	114
7.2.2	Run.....	86	3.3.4	Ping.....	114
7.3	External CV.....	86	3.4	Timbre Modulation Bus.....	115
7.3.1	Pitch Shift.....	86	4	Amplitude.....	116
7.3.2	Root Shift.....	86	4.1	Amplitude Modulation and Ring Modulation	116
7.3.3	Gate Shift.....	86			
7.3.4	Stage Shift.....	87	5	Trimmers.....	116
7.3.5	Vari Shift (Variation Shift).....	87	5.1	Accessible Trimmers.....	116
7.3.6	Pattern Shift.....	87	5.1.1	Coarse Frequency.....	116
7.3.7	Phase Shift.....	87	5.1.2	Sine Wave Symmetry.....	116
7.3.8	Voltage-Controlled Pattern Recall.....	88	5.1.3	Sawtooth Wave Symmetry.....	117
8	Additional Operations.....	88	5.1.4	Exponential FM Zero.....	117
8.1	Select CV Mode (Raw or Pitch).....	88	5.1.5	Triangle Waveshaper Shape.....	117
8.2	CV Range.....	88	5.1.6	Wavefolder Symmetry.....	117
8.3	Gate Width %.....	89	5.1.7	Four-Quadrant Multiplier.....	117
8.4	Swing.....	89	5.1.8	Comparator.....	117
8.5	Current Stage Data.....	89	5.2	Non-Accessible Trimmers.....	117
9	Playing in Tune.....	90	5.2.1	Gain.....	117
9.1	Root & Scale – Dynamic Quantization.....	90	5.2.2	Base.....	117
9.2	Microtonalities.....	90	5.2.3	Symmetry.....	117
9.3	Custom Scales.....	91	6	Technical Data.....	117
9.4	Set the Reference Note.....	92	6.1	Simple Signal Flow.....	117
9.5	Custom Temperaments.....	92	6.2	Revisions.....	119
9.5.1	Absolute or Relative Temperaments.....	92	6.3	Specifications.....	119
9.6	LED Pitch Tables.....	93	CUNSA.....	120	
10	Additional Maintenance.....	95	1	Philosophy and Design.....	120
10.1	Remove / Insert the SD Card.....	95	2	Independent Filtering.....	120
10.1.1	Remove the SD Card.....	95	2.1	Setting the Input Gain.....	121
10.1.2	Insert the SD Card.....	95	2.2	Selecting the Filter/Combo Behavior.....	121
10.2	Analog Trimming.....	95	2.3	Choosing the Filter Type and Slope.....	121
10.2.1	CV Out Trimming.....	95	2.4	Modulating the Cutoff Frequency.....	121
10.2.2	CV In Trimming.....	95	2.4.1	The Frequency Knobs.....	121
10.3	Project Management and Backups.....	95	2.4.2	The Frequency CV input.....	122
10.4	Firmware Update.....	96	2.4.3	The V/oct Input: Filter Tracking.....	122
11	CHARTS.....	97	2.4.4	The Ping Circuit.....	122
11.1	Project Menu.....	97	2.5	Emphasizing the Cutoff Frequency.....	122
11.2	Track Menu.....	97	2.5.1	Resonance and Bass.....	122
11.3	Project Hierarchy.....	98	2.6	Spicing Up the Saturation.....	123
12	Scale Tables.....	99	2.6.1	Using CUNSA as an Oscillator.....	123
13	Change Log.....	106	2.6.2	Ringing the Filter.....	123
14	Technical Data.....	107	3	Linked Filtering.....	123
14.1	Specifications.....	107	3.1	Group Outputs and Mixing Section.....	123
BRENZO.....	108		3.2	Semi-normalled connections.....	124
1	Philosophy, Design and Signal Flow.....	109	3.2.1	Breaking the Semi-normalled Connections	124
2	Frequency.....	109			
2.1	Oscillators.....	109	4	Things Worth Keeping In Mind.....	124
2.1.1	Fine and Coarse Tuning.....	109	4.1	Gain Staging and Saturation.....	124
2.1.2	Coarse Frequency Lock.....	109	4.2	Q, Resonance, and filter slope.....	125
2.1.3	V/oct and Integrator.....	110	4.3	Working with Semi-normalled connections	125
2.2	Frequency Modulation.....	110			
2.2.1	FM Routing.....	110	4.4	The Combined Behavior.....	125
2.3	Sync.....	111	5	Technical Data.....	126
2.3.1	Lock.....	111	5.1	Signal Flow.....	126
2.3.2	Flip Sync.....	111	5.2	Specifications.....	127

BAGÀI	128		
1	Philosophy and Design	128	
2	The clock.....	128	
2.1	Internal Clock Routing.....	129	
2.2	Modulating the Clock.....	129	
3	Noise	129	
4	Fluctuating Random Voltage (FRV) and		
	Global Rate of Change	129	
5	Sample and Hold and Dynamic		
	Downsampler.....	130	
5.1	Sample and Hold Behavior.....	130	
5.2	Audio sampling and downsampling.....	130	
6	8-bit quantized sample and hold	130	
6.1	Quantized sample and hold	130	
6.2	Bitcrushing.....	131	
7	Clock Burst.....	131	
7.1	Bursts Versus Random Clocks	131	
8	Technical Data	132	
8.1	Signal Flow	132	
8.2	Specifications.....	133	
411	134		
1	Design.....	134	
2	Technical Data	135	
2.1	Flow Chart.....	135	
2.2	Specifications.....	135	
333	136		
			1
			2
			2.1
			2.2
			321
			138
			1
			2
			2.1.1
			2.1.2
			PLUS.....
			140
			3
			3.1
			3.1.1
			3.1.2
			3.2
			3.2.1
			3.2.2
			4
			5
			5.1
			5.2
			5.3
			5.4
			Unit (Row Extension).....
			WHAT'S IN THE BOX
			143
			LIST OF REVISIONS
			146

SAFETY AND WARRANTY

The Frap Tools srls warranty covers the following products (hereinafter 'Frap Tools'), for two (2) years following the date of purchase. This warranty covers any defect in the manufacturing of this product. This warranty does not cover any damage or malfunction caused by incorrect use as described in the following instructions.

The warranty covers replacement or repair, as decided by Frap Tools. Please contact customer service at hello@frap.tools for a return authorization.

Frap Tools warrants that your new Frap Tools product, when purchased from an authorized Frap Tools dealer, shall be free of defects in materials and craft for a period of two (2) years from the original date of purchase. Please contact Frap Tools for warranty and service outside of Europe. During the warranty period, Frap Tools shall, at its sole option, either repair or replace any product that proves to be defective upon inspection by Frap Tools. Frap Tools reserves the right to update any unit returned for repair and to change or improve the design of the product at any time without notice. This warranty can be transferred to anyone who may subsequently purchase the product provided that such transfer is made within the applicable warranty period and that Frap Tools is provided with all of the following items:

- all warranty registration information for the new owner;
- proof of the transfer within thirty (30) days of the transfer purchase, and a photocopy of the original sales receipt.

Frap Tools shall determine warranty coverage in its sole discretion: this is your exclusive warranty. Service and repair of Frap Tools products are to be performed only by Frap Tools or an authorized service company. Unauthorized service, repair, or modification will void this warranty.

Please follow the given instructions for the use of the device because this will guarantee the correct device operation. Since these instructions also include indications concerning Product Liability, they must be read carefully. Any claim for defect will be rejected if one or more of the following points is not observed. Any disregard of these instructions can void the warranty.

The devices may only be used for the purpose described in this operating manual. Due to safety reasons, the devices must never be used for purposes not

described in this manual. If you are not sure about the intended purpose of the devices, please contact an expert or Frap Tools at the email address above.

Do not use or store the devices in humid places. Avoid contact with any liquid.

Do not touch any component of the devices when it is power or connected to any power source.

Do not place the devices on unstable carts, stands, tripods, tables, or other surfaces, or on surfaces that are not perfectly plane. Such behavior may cause the devices to fall, which could result in human injury, property damage or improper functioning of the devices themselves.

The devices are designed for use only when safely and tightly mounted in a proper Eurorack case, made of non-flammable materials. If you are not sure about the intended purpose of the devices, please contact an expert or Frap Tools at the email address above.

Do not ever leave the devices switched on when not in use.

To prevent fire, never place any candle, flame, or other sources of heat on or near the devices.

Transport the devices only in the original box with original packaging or when safely and tightly mounted in a proper Eurorack case and handled with care. Never let the devices fall or topple. Make sure that during transport and while in use the devices and their case, have a proper stand and do not fall, slip or turn over because of potential human injury to persons or property damage. Any damage from physical abuse such as dropping the unit, impact from hard objects or damage to external components as a result of negligence will void this warranty.

Never expose the devices to temperatures above +40°C or below 0°C.

Before any operation, also verify the operating temperature ranges of all the modules and the power boards in use. Do not keep or leave the case that hosts the device, or the devices themselves near heat sources.

Any modification must be carried out only by Frap Tools or an authorized service company. The devices may not be modified in any way by any parties not expressly authorized by Frap Tools. Any repair, modification, tampering, or attempted repair made by unauthorized personnel will void this warranty.

Frap Tools cannot be held responsible in any way for problems to persons or property or to

the devices themselves, if the devices are installed improperly, or if they are improperly used, maintained, or stored.

Any device shipped to Frap Tools for return, exchange, warranty repair, update, or examination must be sent in its original packaging! Any other deliveries will be rejected. Therefore, you should keep the original packaging, and any technical documentation or manual provided. The device must be shipped only with the original packaging. As specified on the product box, this box is not intended for shipment: if you bought the device directly at a physical reseller's shop, you should put the device in the original packaging and put the packaging in a properly larger box with proper packaging destined for shipping. If you received the device via carrier or any post service, it should have come with a proper double box packaging.

All non-warranty services are subject to a minimum fee of €50.00+VAT (within the European Union). The customer must pay for shipping to Frap Tools; Frap Tools will cover return shipping costs.

It is important to note that the front panel of our modules may get warm and may warm up the case where it is mounted. Please do not be alarmed, as this is normal and is part of its standard operation.

Shut down your equipment immediately if it produces smoke, a strange odor, or unusual noise. Continued use may lead to fire. Immediately unplug the equipment and contact your dealer or Frap Tools at the address above for advice.

Never attempt to repair this product yourself. Improper repair work can be dangerous. Never disassemble or modify this product. Tampering with this product may result in injury or fire and will void your warranty.

Do not allow foreign matter to fall into the equipment. Penetration by foreign objects may lead to fire.

If water or other liquid spills into this equipment, do not continue to use it. Continued use may lead to fire. Unplug the power cord immediately and contact your dealer or Frap Tools at the address above for advice.

The internal components of our modules and power supplies can get very hot. Do not touch any internal components while it is connected and/or powered and after they completely cool down after use for at least 30 minutes.

BEFORE STARTING

1 CONNECTING THE POWER

To connect the power cable, carefully follow these two rules:

- the power connector on the module is the keyed one at the top;
- the red line on the cable should be placed matching the -12 V side on your power board: please double check with your power board supplier that the marked side is the -12 V .

Frap Tools may not be held responsible in any way for problems or damage to persons or property or to the device itself if the device is not connected as indicated above.

2 MOUNTING THE MODULE

After connecting the power as explained in the previous section, install the module in your case using all the 2 or 4 screws provided. Make sure that the module is safely and tightly connected to your Eurorack case.

Frap Tools modules use the standard Eurorack orientation and color-coding: the red line on the power cables is placed at the bottom and stands for the -12 V . Please

double check with the power system you want to use that it adopts the same powering system.

Frap Tools may not be held responsible in any way for problems or damage to persons or property or to the device itself if the device is not connected as indicated above.

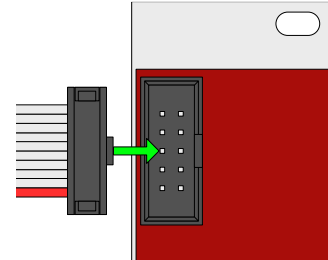

Figure 1: Power connection.

3 WARM-UP AND WORKING TEMPERATURE

For best performances, we suggest letting the Frap Tools modules warm up for at least around 20 minutes before using them [tested at 25°C]. It is normal that they feel warm when touched.

MODULAR SYNTHESIS: CORE CONCEPTS

In this introduction we'll go through the basics of analog modular synthesizers in their broader meaning, to make sure that all the technical jargon that we'll be inevitably using throughout the manual will be, hopefully, clarified for the newcomers.

Modules in a modular synthesizer can be thought of as strangers sitting next to each other in a train compartment in an embarrassed silence.

Creating music from a modular synthesizer is like starting a conversation on our hypothetical train compartment, by connecting modules with patch cables and making them "speak" to each other.

For any conversation to happen, we need two things: the people must have something to say (like an argument), and they must speak the same language.

In modular synthesizers, the argument is your musical idea, and it is beyond the scope of this manual, while the common language to make your modules communicate is the *voltage*.

1 VOLTAGE (AND CURRENT)

Even though this is not an engineering manual, a general introduction to the concept of voltage might be useful to better understand how these instruments work.

Voltage is the difference in electric potential between two points of a circuit, or, oversimplifying, «what you apply to cause currents to flow.»¹ It is measured in volts, whose symbol is V. Without any other specification, the voltage is calculated between any point of the circuit and a reference point called *ground* (0 V).

Electric potential brings in the concept of *current*, which is the actual flow of electric charge through a circuit. Electric charge is measured in coulomb (C), while the current is measured in amperes (A): 1 ampere equals 1 coulomb of charge passing through a given point in 1 second.

Enough for the technical stuff: now it's time to see how voltage and current turn into (electronic) music.

2 DC AND AC

There are two kinds of current, each of which implies a different kind of voltage. They are *direct* and *alternating* current, abbreviated *DC* and *AC* respectively, and we use both in modular synthesizers.

In the case of direct current, our charge flows only in one direction: if the current is steady, so will the voltage. This kind of fixed voltage is what we use, for example, to send note information to the sound source.

In the case of alternate current, our charge flows back and forth in our circuit. Its alternation over time can be displayed with a waveform diagram. The voltage changes over time as well: we use this kind of varying voltages to generate, for example, waveforms that ultimately will turn into sound.

3 AUDIO AND CV

To hear music, we need some vibrating air. To make the air vibrate, we need a vibrating body: we can pluck a string, hit two wood sticks, blow into a pipe, and so on.

In the case of electronic instruments, our vibrating body is the loudspeaker (or the headphones).

More in detail, in the specific case of analog modular synthesizers, everything, from the sound generation to its articulation to the final audio output through the speaker cone's vibration, is achieved through voltage that changes over time.

With our modular synthesizer, we create a complex, electric signal that makes our cones move back and forth. The variation of voltage over time translates into the complex waveform that we call music.

It goes without saying that the more control we have over our voltage, the more expressive and articulated will become our composition's waveform.

In modular synthesizers, we use voltage to generate sound, but also to control it.

If a circuit generates a voltage that varies from, say, -5 V to 5 V, 110 times a second, it will make our loudspeaker vibrate as many times, thus producing a sound whose *frequency* is 110 Hertz (Hz), corresponding to the note A.

However, if the same circuit generates a voltage oscillation of 10 Hz, meaning that the voltage varies from -5 to 5 V ten times a second, we wouldn't be able to hear it anymore. It's because its frequency is below our audible range of human beings, which spans from 20 to 20.000Hz.

This brings in a conventional distinction between voltages that we use for sound *generation*, which provide alternate current in the audio range, and voltages that we use for sound *modulation* or *control*, which are often called *control voltages*, or CV. Generally speaking, we use CV to turn our modules' knobs for us, in a sort of automated way.

CVs can be of any kind: they can generate alternate current, such as low-frequency oscillators (LFOs, like the ones we use for tremolo effects) or direct current (like the fixed CVs that we use to send pitch information).

¹ (Horowitz 2019, 1, note 2.)

It is nice to point out that in modular synthesis we use the same two or three principles to take care of every *parameter* of the sound design.²

4 TIMING PULSES

We use CV to distribute information (like pitch, amplitude, or timbre) all over our electronic composition.

For example, the information of “C#4” is not enough to generate a note: it generates just a pitch. To have a note, we need to give it some timing: when it begins, how long it lasts and when it ends.

For this kind of information, which is essential to define any kind of musical event (note, melody, rhythm), we use a particular kind of CV called *timing pulses*, which are *triggers* and *gates*.³

Triggers and gates are *pulses*, because they can have only two values, off and on, and because the transition between one value and the other is almost immediate. *Off* is usually 0 V, and *on* is around 5 V.

The main difference between triggers and gates is that triggers are very fast voltage bursts that go from 0 to 5 V and immediately (actually, after one or two milliseconds) back to zero, while gates can stay at 5 V as much as we want.

A trigger is thus a timing pulse that defines when a certain musical event should happen, while a gate is a timing pulse that tells when such an event should happen, but also exactly for how long.

Triggers are the kind of pulses that we get out of clock generators, such as SAPÈL, while gates are generated by modules such as FALISTRÌ or USTA, which are more focused on articulation and dynamics.

5 POLARITY

We have said that voltage is a difference in electric potential that causes the current to flow through a circuit. Such a current can flow through a point in either direction, depending on the voltage that we apply to the circuit. A positive voltage will make the current flow in one direction and a negative one in the opposite. (0 V will not have any current flow, and such is the value of the circuit’s *ground*.)

In the case of alternating current, the voltages are also alternating. If such alternation oscillates above and below 0 V, the voltage would be *bipolar*. However, there are cases in which the change in voltage is only positive (or, more rarely, negative). In such cases, we say that the voltage is *unipolar*.

The most common bipolar voltages are the ones used for generating audio waveforms since they need to move

the speaker’s cone back and forth. A unipolar audio signal would make the cone move in one direction only, with potential damage.

Unipolar voltages are, for example, certain envelopes, or LFOS, especially the ones used for controlling a parameter that needs to operate in one direction only, such as amplifiers (on which see § 7).

6 NOTES, TRACKING, V/OCT

When we think about a note, we imagine a very precise thing: a musical event with a beginning, an end, and a recognizable frequency. We also associate the note with the performative act that creates it, whether it be pressing a piano key, programming a MIDI sequence, or blowing a flute with some holes closed.

Due to the parametric nature of modular sound synthesis, what we call “note” is broken down into smaller pieces.

We have a CV that changes an oscillator’s frequency, the oscillator that creates the sound, the timing pulse that triggers an envelope, the envelope that opens and closes a VCA, the VCA that defines what is a note and what is silence, and many other things in between.

We already discussed the timing pulses, so now we need to focus on how we can change the pitch of our oscillator to create notes.

In the physical world, there are infinite frequencies. Over thousands of years, we as human beings ended up selecting only a select few of them that, when played together, sound “good”. If this seems quite arbitrary, it’s because it is.

The difference between two frequencies is called an interval: an interval can be consonant or dissonant according to how “pleasant” it sounds (again, this is very arbitrary, but sometimes there is a mathematical reason for this that we’ll leave outside this manual for now).

There are different sets of intervals around the world’s many cultures. The most common one in the West takes the octave as the most important interval, and an octave is an exact doubling in frequency. Two sounds an octave apart are so harmonically similar that we name them in the same way, so, for example, a frequency of 440 Hz is arbitrarily named A, and a frequency of 880 Hz is still an A, but an octave higher.

In the West, after centuries of music, we eventually divided the octave into 12 equally spaced intervals called “semitones.” The semitones allow us to create many rather pleasant intervals without any unbearable dissonance.

In the Eurorack standard, we can achieve this set of intervals through the V/oct standard, which associates to a

² On the importance of *parametrical* thinking when approaching analog sound design, see especially (Strange 1984, 4–5).

³ (Strange 1984, 51–52, 61–62)

one-volt increment an octave interval: as a result, a semitone is exactly $1/12^{\text{th}}$ of a volt.

However, the V/oct standard needs two things to operate: a controller capable of outputting discrete $1/12$ V controls, and an oscillator that can interpret those signals and change its frequency accordingly.

The modular synthesizer can thus teach us a valuable lesson: a “note” is not the control signal, it’s the frequency of the oscillator. We can compare the oscillator to a guitar string and a V/oct signal to the fretboard: the fretboard is just a fixed set of intervals, but the notes we get depend exclusively on how the string is tuned.

What we just said may not be obvious for those who are mainly familiar with MIDI instruments, where every note has a name and is associated with a specific frequency: this may lead to erroneously believing that a key, a MIDI number, and a frequency are the same thing.

In modular synthesizers, the fact that our controller says C doesn’t mean anything until we tune our oscillator to that C.



Watch an in-depth discussion on music notation here:
[The conventions of music: what is a note?](#)

An oscillator’s ability to correctly interpret a V/oct signal is called tracking, and it is possible through exponential converters.

As we said, an octave is a doubling in frequency, so an interval of two octaves is the base frequency multiplied by four, three octaves by eight, and so on. This is an exponential behavior, and it’s how we perceive notes.

However, an increment of 1, 2, and 3 volts is linear: so, we have a controller that outputs linear CVs and an oscillator that must exponentially interpret them. (This is not obvious at all, and as a matter of fact, some vintage synthesizers used a V/Hz standard, where the ratio between voltage and frequency is always linear. But that’s not relevant now.)

As of today, we have three modules that can track: BRENSO, FALISTRİ, and CUNSA. They have different purposes and thus achieve tracking behavior in different ways and with different results.

BRENSO and FALISTRİ are very similar: they create rising and falling voltages that can become a sound when at audio rate, or a modulation source when slower than 20 Hz.

This happens through a combination of integrators and comparators: when the integrator reaches the comparator threshold, it inverts its direction until it finds another comparator threshold, and thus keeps going up and down.

It is possible to change the frequency by making these cycles faster or slower through a CV. Both BRENSO and

FALISTRİ have an exponential converter that allows us to change the frequency according to the V/oct standard, and it exploits a natural characteristic of transistors. The topic is quite technical and beyond the scope of this introduction, so for now suffice it to say that there is a small operating window where a transistor controlled by a linear voltage can “open” in an exponential way, thus letting a second voltage pass through by exponential increments.

The circuit is indeed more complex and includes a bunch of components to make the transistor’s behavior stable and less prone to temperature changes, but most importantly, it had to be tailored to the different purposes of BRENSO and FALISTRİ. BRENSO was born as an oscillator, so the priority was good tracking over 7 octaves and waveform shape preservation at every frequency.

FALISTRİ is a more versatile module: it had to stop cycling when used as an envelope, we had to be able to control the rising and falling times differently, and it also had to output steady high and low voltages for the Hold and Rest stages. Besides those extra functions, it obviously has a much greater range than BRENSO, where a cycle can be longer than 10 seconds, so it was impossible to guarantee tracking and a wave purity as precise as a dedicated audio oscillator module. Still, the unique wave shape of FALISTRİ is what makes it interesting as an oscillator, and it can track up to 5 octaves.

CUNSA is a completely different beast because it is a filter. Still, it is often useful that a filter tracks together with the oscillator, to preserve the same harmonic content of every note (see below). On top of that, at high Q settings, a filter can oscillate and produce a sine wave. If the cutoff frequency responds to a V/oct signal, it is possible to “play” the filter as an oscillator.

To change the cutoff frequency, the CUNSA uses a circuit called *operational transconductance amplifier* (OTA). By controlling the amount of current that feeds a capacitor, it is thus possible to leave out the faster or slower frequencies in a lowpass or a highpass frequency respectively.

Since the response of the OTA is already exponential, it can easily convert a linear V/oct signal with some precise adjustments.

However, because CUNSA is a filter, its behavior as an oscillator is a byproduct and by no means can be compared to BRENSO.

7 AUDIO AND CV PROCESSING

In modular synthesis, we add dynamics and expressiveness to our music through signal processing. We use quite a few concepts, but their combination provides many different results.

The most important element of signal processing is the control over a signal’s *amplitude*. Amplitude is, roughly,

how loud we perceive the sound, which means how much the air vibrates, which also means how much our speaker cones vibrate, which, in turn, means how high the voltage oscillation that we generate with our synthesizer is.

Controlling the amplitude of a signal means being able to define the voltage range of our sound source, which is bipolar: for example, an amplitude of 5 V means that our waveform will go from 0 V to 5 V, and then from 0 V to -5V throughout each cycle. Since there is a difference of 10 V from 5 V to -5 V, we can also say that our signal has an amplitude of 10 V peak-to-peak (V_{pp}), i.e., measured from the highest to the lowest point of the waveform cycle (“peaks”).

There is another way of measuring a signal’s amplitude, and it’s the root-mean-square amplitude (RMS). In electronics, this concept is useful because it expresses the value of a periodic signal (like alternating current) as if it were a constant signal of equal average power (like direct current).⁴ It is not necessary to dive too much into this concept now, but we needed to introduce it because we’ll refer to V_{rms} values in the next section about signal levels.

The circuit that allows us to control the amplitude is called an amplifier: increasing or decreasing the amplifier value, usually through a knob, increases or decreases the amplitude of our sound, and eventually brings it to 0 V, where no sound is passing through the circuit. An amplifier is often capable of increasing a signal’s amplitude, thus providing a louder sound than the one generated by our sound source. A circuit that only reduces a signal’s amplitude is often called an attenuator.

Furthermore, amplifiers can also deal with signals that are not waveforms, such as control voltages. In this case, amplifiers control the voltage magnitude, and they can make control sources and their modulations more or less effective in a patch.

An amplifier that we can control through voltage is called a VCA (voltage-controlled amplifier). For example, if we control an amplifier with an LFO (a Low-Frequency Oscillator), this will cyclically increase and decrease the signal’s amplitude, like a tremolo effect. But we can also control the LFO’s amplitude through a second VCA, and now it will change the modulation depth.

Another useful concept to outline now is *inversion*, which relies on the fact that voltages, in Eurorack synthesizers, can be positive or negative. Inverters are circuits that change the polarity of a given signal: on a graphical representation, the result of an inverted continuous voltage will be a mirrored, upside-down version of the original signal.

If the signal is bipolar, the positive values will become negative, and vice-versa.

We can also invert audio signals, and in such cases, we’ll invert their *phase*.

A circuit capable of attenuating and inverting a signal with the same knob is often called an *attenuverter*: the usual design allows you to increase a signal’s amplitude by rotating the knob to the right, and invert it by rotating the knob to the left.

8 FILTERS

A filter is a circuit that removes a certain spectral portion from the sound that passes through it. A lowpass filter removes the higher frequencies (and lets the lower ones pass through, hence the name); a highpass filter removes the low frequencies; a bandpass filter removes both and lets only a middle section pass through. A common bandpass filter design is a highpass filter and a lowpass filter in series. FUMANA, for example, consists of various bandpass filters in parallel.

8.1 IDEAL AND REALISTIC FILTERS

An ideal filter should remove any sound above or below a certain frequency, which is called *cutoff frequency*.

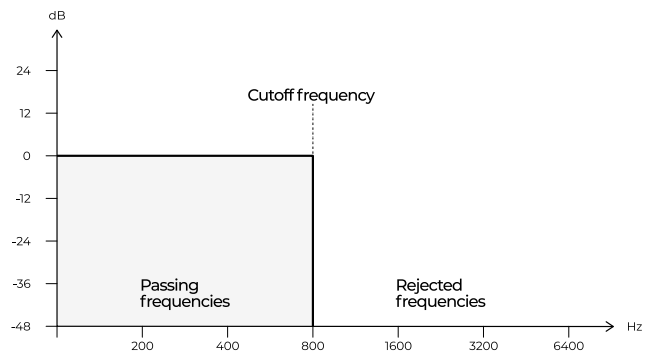

Figure 2: An ideal lowpass filter.

However, in the real world, this is not possible, and many frequencies love to sneak out of the filter even if they are past the cutoff threshold. They are progressively quieter as they move away from the cutoff frequency until finally there are no more of them.

The spectrum’s portion between the cutoff frequency and the actual silence is the filter slope, and it can be wider or thinner according to the filter design.

The width of this filter slope is measured in dB per octave, which indicates how quiet a frequency is compared to its lower octave when both are past the cutoff frequency. For example, if we have a lowpass filter with a 6 dB/oct slope and we set the cutoff frequency at 440 Hz, the frequency of 880 Hz, which is an octave higher, will be 6 dB lower, so half of its amplitude; the frequency of 1760 Hz will be 12 dB lower, and so on until the

⁴ (Horowitz 2019, 14)

attenuation is so high that we can no longer perceive that frequency: at that point, we can finally say that the frequency is filtered out.

However, 6 dB/oct is quite a generous filter because it lets a lot of sound pass through. It is the kind of filter that you may find on hi-fi equipment since it can perform some degree of “correction” without altering too much the nature of the sound.

Two more common filter designs for musical purposes have a 12 dB/oct slope and 24 dB/oct slope, which create a more dramatic filter effect.

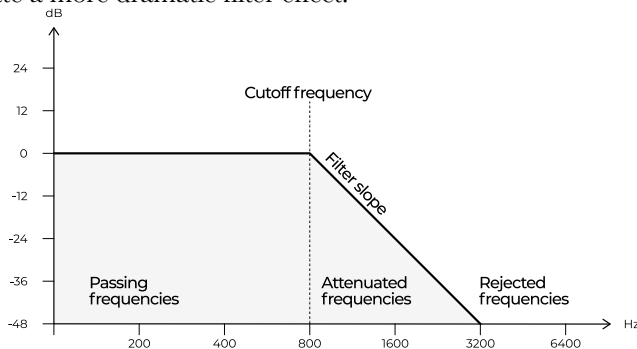

Figure 3: A lowpass filter with an ideal 24 dB/oct slope.

Other terms used to define the slope of a filter are ‘order’ and ‘poles.’ The terms relate to the engineering and mathematical sides of a filter, respectively, and it would be a bit too technical to dive into such topics, so we’ll point to the bibliography for the reader who wants to gain deeper knowledge. For now, the following table shows how the terms relate together:

Slope	Order	Poles
6 dB/oct	First	1
12 dB/oct	Second	2
18 dB/oct	Third	3
24 dB/oct	Fourth	4

Table 1: Filter naming conventions.

And so on. For example, a filter with a slope of 36 dB/oct can be indiscriminately called a 6th order filter or a six-pole filter.

However, even a perfect filter slope after the cutoff frequency is impossible in the real world. Every filter design has a zone around the cutoff frequency where the amplitude of every frequency is no longer “full,” but neither attenuated with a proper slope yet.

This sort of “transition zone” also affects the frequencies below the cutoff frequency, and they might get progressively duller as they approach it. A realistic representation of a 24 dB/oct filter might thus be something like

this, where the dotted line represents the ideal slope of the previous diagram.

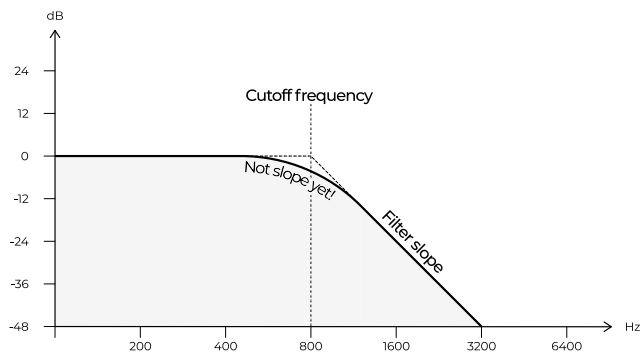

Figure 4: A lowpass filter with a realistic 24 dB/oct slope. Notice the area around the cutoff frequency.

8.2 FILTER TRACKING

We have said that a filter progressively attenuates all the frequencies past a certain threshold until complete silence.

Having a fixed cutoff frequency means that the notes we play with a filtered oscillator will get progressively duller and quieter as we approach and cross the cutoff frequency.

Let’s take for example a lowpass filter with a 24 dB/oct slope. We might find a nice filter tone for an A at 110 Hz, but the effects over an A at 220 Hz will be greater, and even more at 440 Hz. The three notes will have a completely different harmonic “color.”

By making the filter track with the oscillator, instead, we progressively shift the cutoff frequency according to the oscillator’s pitch, thus making all the notes have proportionally the same harmonic content.

In modular synthesizers, the easiest way to achieve perfect tracking is to have a filter that responds to V/oct signals, as we explained in the previous section.

8.3 BEYOND FILTERING: Q

When used for musical purposes, filters can go beyond removing frequencies: lab precision is not a priority, and musical filters might even add some extra timbre to the sound, as long as it’s “pleasant.” There are many filter designs, and they differ from one another by the extra flavor they add to the source signal.

One of the most common “additions” is the Q control, also called ‘emphasis,’ ‘resonance,’ ‘feedback,’ and other terms. The resonance emphasizes the cutoff frequency, often by a re-injection of the filtered signal to its input. Since it involves a feedback design, the cutoff frequency can be emphasized so much that it starts oscillating with extreme Q settings.

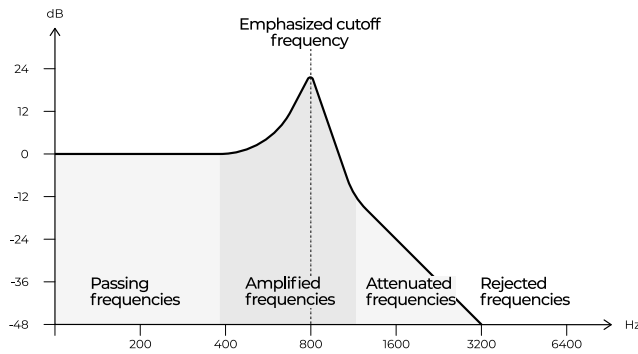

Figure 5: A 24 dB/oct lowpass filter with high Q settings.

This produces a sine wave whose frequency is the same as the cutoff frequency. When the circuit is filtering an external signal, the new sine is summed to it; however, many filters can also oscillate by themselves, so they can output one of the purest sine waves of the analog domain with no input.

If such a filter's cutoff frequency can be controlled with a V/oct signal, a resonant filter can become an actual sine wave oscillator.

Being a filter an electronic circuit, it is subject to the structural limits of its components. It has a certain headroom to accommodate the incoming sound, after which it will saturate or distort the signal. Sometimes this can be a desired effect, and many filters allow you to boost the signal input way past its headroom to saturate the circuit.

Filter saturation was one of the key features we had in mind when we designed the CUNSA.

9 AMPLITUDE MODULATION AND RING MODULATION

Let's go briefly back to the VCA. If we control a signal's amplitude through an LFO, we obtain a tremolo effect. However, if our LFO goes faster than 20 Hz, it is no longer a "low frequency" oscillator, but an actual oscillator.

At this point, we no longer perceive the tremolo effect. Instead, a new sound with richer overtones comes in. It is the result of the so-called amplitude modulation, and the new overtones are called sidebands.

These new overtones, or sidebands, are the exact sum and difference of the two signals that we had in the beginning, that we now will call carrier and modulator.

The sidebands highly depend on the waveform of the two signals: a sine wave will produce only two sidebands, the sum and the difference of the two frequencies.

Other richer waveforms, however, will generate as many sidebands as the sum and difference of their overtones, proportionally to their amplitude.

Speaking of sum and difference, if the result of the difference between the two frequencies is a negative number, it translates into an overtone with an inverted phase. This happens when the modulator's frequency is higher than the carrier one.

If the frequencies of the carrier and modulator are in a harmonic relation, like if they are the same frequency, or one is twice, three, or four times the frequency of the other, the result will be a harmonic sound.

If their relationship is inharmonic, the result of ring modulation will be similar to metallic, bell-like sounds.

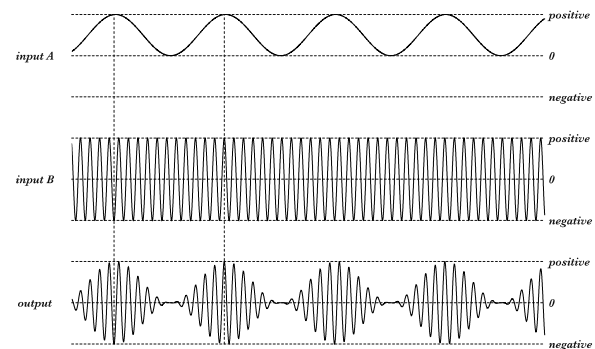

Figure 6: Amplitude modulation (AM).

As you can see from the graph, the top signal, which is our modulator, is unipolar, just like when we modulate a VCA. This is the reason why we often call AM *unbalanced modulation*.

If both signals are bipolar, we have the so-called *ring modulation*, or RM, *balanced modulation*. Whenever the modulator reaches the negative side, the carrier signal will be amplified again, but with an inverted phase. It is the equivalent of modulating an attenuverter at audio rate.

The sidebands are the same as for balanced modulation, but their intensity is much higher. The carrier pitch in RM is completely suppressed, leading to a sharper sound.⁵

⁵ More details on AM and RM in (Strange 1984, 117–29; Roads 1996, 215–24).

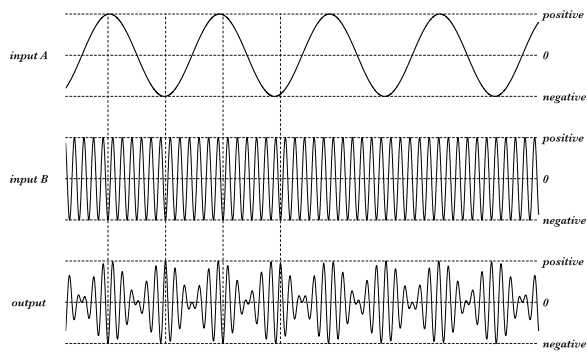

Figure 7: Ring modulation (RM).

10 FREQUENCY MODULATION

When an oscillator's frequency is modulated at a sub-audio rate, this generates noticeable fluctuations of the pitch, similar to a vibrato effect.

When the modulating signal runs at audio rate, the human ear can no longer perceive the fluctuations: instead, the result of audio-rate *frequency modulation* (FM) is a more complex sound whose timbre is a result of the interaction of the two frequencies (that of the oscillator being modulated, which is usually called 'carrier,' and that of the 'modulator').

Depending on how the modulation is applied to the carrier signal, FM can be *exponential* or *linear*. Linear FM modulates the carrier based on the frequency: in other words, in linear FM, the modulator increases and decreases the carrier frequency by the same Hz value, according to the modulation amount. Exponential FM modulates the carrier based on its pitch, i.e., with intervals: a symmetric bipolar signal will thus increase and decrease the carrier frequency by the same interval (for example one octave), according to the modulation amount.

The change in timbre is due to the generation of other frequencies, called 'sidebands,' in a similar fashion to what we saw for AM and RM. The difference between AM/RM and FM sidebands depends on the kind of modulation (exponential or linear) and the modulation amount (higher=more sidebands, and vice versa).

10.1 EXPONENTIAL FM

In the early days of analog synthesis, frequency modulation was mainly exponential due to the oscillator's design. It was possible to have an "audio-rate vibrato," which created some interesting, metallic timbres, but it had a downside: it wasn't possible to play melodies.

This happens because the exponential modulation is asymmetrical: if an A=440 Hz waveform is modulated exponentially, and the modulation amount is $+/-1$

octave, the carrier frequency will oscillate between 220 Hz and 880 Hz, which is 220 Hz below and 440 Hz above the original frequency. Such modulation also causes a shift of the central frequency: in this case, it will be 550 Hz, which is exactly 330 Hz above 220 Hz and below 880 Hz.

This, in turn, will generate a perceived detune of the original pitch, which will be different every time the carrier frequency changes. For example, if we modulate a B4 (493.88 Hz) by $+/-1$ octave, the perceived pitch will be 246.94 and 987.77 Hz, so 617.355 Hz, and so on.

Exponential FM generates sidebands that are not equally spaced above and below the carrier frequency, which makes them way harder to calculate, compared to AM and RM sidebands⁶.

10.2 LINEAR FM

The downsides that exponential FM shows in certain applications can be easily overcome with linear FM, which brings into the world of audio synthesis some well-known concepts of electronic communications thanks to the research of John Chowning.⁷

The concept is the same as with Exponential FM: the only difference is how the modulation is applied to the carrier. Instead of shifting its frequency up and down by musical interval, here we use the frequency: our A4 (440 Hz) can now shift up and down by the same amount, like $+/-100, 200, 800$ Hz.

The first consequence of this technique is that we can retain all the original pitch information, without any drift.

The second consequence is that we can have much more harmonic and predictable sidebands since they are equally spaced above and below the carrier frequency.

The number and amplitude of sidebands are proportional to the amount of modulation that is applied to the carrier, which is often called 'deviation': this value defines the difference between the carrier's frequency and the higher or lower frequency that it reaches when modulated. The more deviation, the wider will be the fluctuations of the carrier frequency, and the greater the number of sidebands.

The relation between the deviation and the modulator's frequency, both expressed in Hz, defines the FM Index. (For example, if the modulator's frequency is 200 Hz and the deviation is 400 Hz, the FM index would be $400/200=2$.)

In linear FM, the sidebands are the sum and difference of the carrier and integer multiples of the modulator. There can be some cases, however, in which the difference between the carrier and the modulator would

⁶ Further explanation of the audio spectrum of exponentially frequency-modulated oscillators in (Hutchins 1975).

⁷ See the pioneering (Chowning 1973) for a more detailed explanation.

provide a negative number, which gives us a “negative frequency”: for example, if the carrier frequency is 150 Hz and the modulator frequency is 200 Hz, the first couple of sidebands would be at 350 Hz and -50 Hz, which is 50 Hz with inverted phase.

In digital synthesis, this is no big deal. However, a conventional analog oscillator stops oscillating whenever it reaches 0 Hz, thus losing these negative sidebands.

For this purpose, new analog oscillators capable of not stalling at 0 Hz were developed, including our BRENDO. This technique is called *Thru-Zero FM* because the oscillator goes “through 0 Hz:” this term, however, is meaningful in the analog domain only, since in digital FM the negative sidebands were always there. As Chris Meyer put it, “Through Zero FM is linear FM *that just works*.⁸

FM in the analog domain is often an approximate process, because of the difficulty for the analog components to guarantee a precise ratio between carrier and modulator frequencies.

11 SAMPLING AND QUANTIZING

Sampling is a common technique in the world of electronic audio synthesis, and the chances are that your synthesizer is doing more sampling than you think.

Being so popular, the term *sampling* came to signify three apparently different things according to the context:

- as in “sample and hold;”
- as in “sample rate;”
- as in “sampler” or “sample player.”

However, despite evoking completely different devices, these expressions ultimately derive from the same concept.

Sampling, in its most abstract form, consists of measuring the momentary value of a signal, as in “taking samples” of it.

A sampling circuit is thus a device capable of detecting the magnitude of a signal at a given time, and it needs a control signal to understand when to sample, like a timing pulse.

If the sampled signal is a plain DC offset, the sampler will always detect the same value. That is why a sampling circuit is always used with animated signals like noise, functions, or audio.

If the sampling circuit can retain the sampled value, until a new timing pause comes in, it is called ‘Sample and hold,’ abbreviated to S&H. Such a circuit is the basis for our Sapèl and Bagàì modules.

In Sapèl, the sampled signal is fixed: it is an analog thermal noise, and since its fluctuations are truly random, the

outcome is a stream of unpredictable values that never repeat.

The timing pulses come from an internal clock, so the random values will all be outputted at regular intervals. It is also possible to use external signals or even a manual button to activate the sample and hold circuit.

Bagàì works in the same way, but the input is open so it is possible to use other signals than its thermal noise.

Sampling an LFO, for example, can produce ascending and descending patterns of voltages similar to scales.

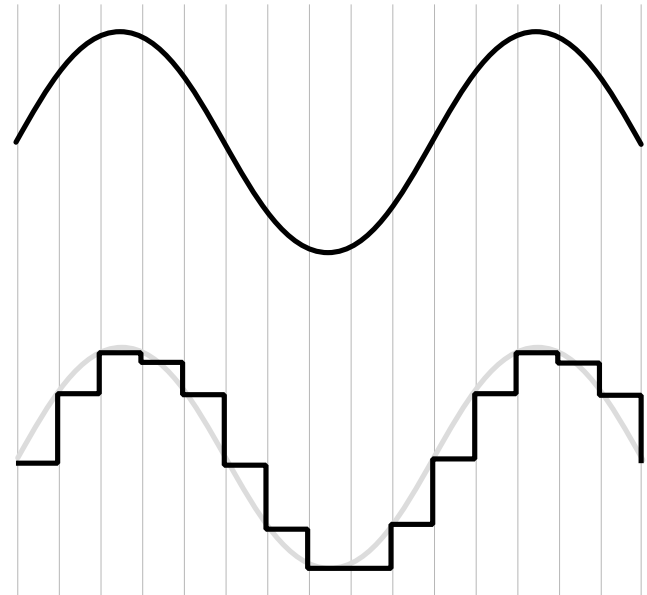

Figure 8: Sampling an analog signal (top) at regular intervals (bottom) produces a stepped voltage.

The faster the clock goes the closer the sample and all output will get to the input, which brings in the topic of...

11.1 SAMPLE RATE AND AUDIO SIGNALS

If the frequency of the timing pulse is controlling our sample and hold is fast enough to go to audio rate, we may no longer perceive a difference between the original signal and the sampled one. And, if the frequency is fast enough, we may even sample audio signals!

Audio sampling is exactly what happens when you use a digital module: there is an internal clock that goes really fast (at least 44,100 times per second) that samples the audio signal.

However, a digital sound processor (often abbreviated as DSP) only accepts discrete values that can be squeezed down to zeros and ones, and if we are using a regular sample and whole technique, we can still have infinite values. We must now introduce the difference between

⁸ (Meyer 2018). A comparison of AM, RM, and FM is in (Strange 1984, 118).

analog and digital sampling, and such a difference is quantization.

11.2 QUANTIZATION AND DIGITAL SAMPLING

When we sample any waveform that goes from -5 to 5 volts, the S&H circuit can pick whatever value between those voltages, because it is an analog sampler sampling an analog signal.

If we need to convert an analog signal to a digital one, we also need to limit the pool of sampled values to something readable by a machine that uses only 0's and 1's. This process is called *quantization* and uses bits, which is short for 'binary digit.' The more bits we use to quantize the higher our pool of possible sample values will be. The number of bits that a circuit can use to sample signals is called bit depth.

For example, if we only have one bit, the output of our circuit will be a square wave, regardless of the input, because a bit only has two states and will thus approximate every value to "off" or "on." Bits can indeed have two states only, low or high, much like a gate, which we may call a digital voltage for this reason. However, by stacking more bits we can combine the respective states, thus increasing the pool of values exponentially.

If one bit has two states, two bits will have four, four bits 16, eight bits 256, and so on.

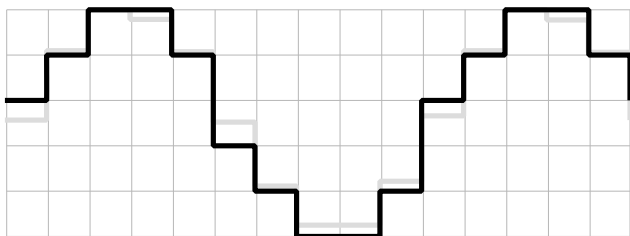

Figure 9: Quantizing the previous example's sampled signal (grey). Notice how the output signal (black) gets "forced" to the closest available value.

The higher the bit depth, the more "faithful" will be the digital representation of the analog signal. Once these sampled signals are stored and recalled in a digital memory, they are often called "samples," and by extended meaning, a device capable of recording, storing, and playing back audio samples is called "sampler" or "sample player."

So, we saw two kinds of sample and hold circuits: analog, where it can output any value, and digital, where it can output only the values defined by the bit depth or quantization mask.

This is precisely what happens with two circuits that can be found in Sapèl and Bagài.

Sapèl's $n + 1$ and 2^n outputs use a six-bit circuit to quantize the internal random noise to octaves and semitones respectively, following and expanding Don Buchla's tradition of quantized random voltages.

With the default behavior of Sapèl's random voltages, we don't know what voltage will come out of the output, but we know that it will be one of those in the quantization mask and that it will happen with a clock impulse.

On Bagài we have an 8-bit circuit with variable bit depth. The values are much more than Sapèl, 256 instead of 64, so it can process audio signals as well with reasonable approximation, especially thanks to its open input and its clock that can go as fast as over 30 kHz.

Both modules also feature an analog unquantized sample and hold output, which works in the same way but with infinite values.

The peculiarity of Bagài is that we can change the clock speed, which is also called the sample rate, as well as the bit depth. These operations are considered "mistakes" in the world of digital audio because they introduce errors in the reproduction of the input waveform.

For example, if the clock is not fast enough it will not be able to reproduce the whole waveform. If the bit number is not high enough the waveform will have a rough squared-out aspect.

However, those are issues only when our goal is to convert an analog signal into the digital world, thus obtaining the closest possible representation of the original analog waveform, much like a photograph of a painting for an exhibition catalog.

In our Bagài, however, this is not the case since the signal input is already analog. Instead, we can arbitrarily change the sample rate and bit depth on purpose to change and distort our original sound to continue the photograph metaphor this can be thought of as an art photograph. These techniques are called *bitcrushing* and *downsampling*.

12 AUDIO LEVELS

In the previous section, we said that a sound's amplitude is related to how loud or soft we perceive it. Loudness, however, is a tricky value because it always needs to be measured against a reference point. Since the human ear is sensitive to dramatic pressure changes, to measure such changes it is always used a logarithmic unit called *decibel* (dB).⁹

Audio equipment marks with 0 dB the "reference value," which is usually the point at which the signal can get the maximum strength without distorting. However, many circuits allow us to increase the sound loudness

⁹ For a description of the decibel units, see (Strange 1984, 142-143; Horowitz 2019, 15)

beyond 0 dB: the range where we can push our sound is called *headroom* and usually stretches at least until 12 dB.

Since the dB is a relative unit, the 0 dB level can change from device to device. For this reason, such a reference value is often calculated on the circuit’s absolute voltage RMS amplitude (see the previous section). Some V_{rms} values have now become standards, for example:

Equipment	0 dB amplitude
Consumer/Hi-Fi equipment (often with RCA connectors)	300 mV _{rms}
Professional equipment	1.228 V _{rms}
Eurorack synthesizers	3.535 V _{rms}

Table 2: Common 0 dB Reference Values

The Eurorack V_{rms} value is calculated on a sine wave of 10 V_{pp}, i.e., a bipolar signal of ± 5 V.

A circuit’s headroom depends on the equipment’s power source. In the case of Eurorack systems, the available voltage is less than ± 12 V, for a total of 24 V; studio equipment is usually between ± 15 V (30 V total) and ± 18 V (36 V total), with some rare cases even beyond ± 24 V (48 V total).

13 WORKING TEMPERATURE

Every electrical circuit generates some thermal energy whenever the flow of electrons is restrained. This can happen on purpose, when we need to reduce the flow of electrons, or accidentally, due to the natural resistance of any conductive material. The energy that an electron loses through resistance is converted into heat.

This connection between electricity and heat also works the other way around: the temperature of every circuit’s component affects the flow of electrons and, more broadly, the circuit’s performance. Every piece of a circuit thus has a temperature range where it performs as expected, while at higher or lower temperatures it may perform differently.

From these two physical facts, we can draw three conclusions that are very relevant to our modular synthesizer.

The first one is that the more components a module has, the more heat it will produce. The thermal energy always looks for the easiest way to spread out, which, in a Eurorack module, is the aluminum front panel.

It now becomes clear why the modules with more components are generally warmer than those with fewer, and also why our modules are generally among the warmest in the market: since they do many things, they require a lot of components in a limited space.

The second conclusion is that analog equipment needs some time to warm up the circuit and make every

component reach a proper working temperature. This time may vary according to many factors, like:

- The case (open, sealed, metallic, wooden);
- The environment temperature;
- The proximity of other warm modules.

The third conclusion is that the temperature around the module might affect its behavior. By “around” we mean both the room temperature and the one *inside the case*. As a matter of fact, shallow or deep cases create different air convection patterns, and even the module’s position (vertical or horizontal) is a factor that sometimes plays a role.

We have said that nearly every electrical component has an operating temperature and might be prone to temperature changes. Most components might alter their behavior up to 1% through small temperature changes, which sounds like a small number, but if you think about an oscillator with a frequency range of roughly 120 semitones, a 1% drift is a lot.

This introduces the necessity of thermal compensation, which is the art of balancing the components’ thermal deviation with another deviation of equal magnitude and opposite direction.

Sometimes it is possible to compensate a circuit by balancing its individual components’ thermal drifts: these are called “self-compensating circuits.”

However, most of the time it is necessary to introduce an external component with the specific purpose of balancing another one: it is the case, for example, of thermal resistors used to balance the very touchy transistors that we discussed in the chapter on V/oct tracking.

The ideal thermal compensation would immediately correct the drift by the right amount: at this point of the reading, you may have already guessed that this ideal circumstance is nearly impossible. Every compensation strategy thus requires some time to adapt to the other components, besides a stable working temperature. The fine art of compensation and circuit stabilization is also the reason why trimmers exist: they are an excellent tool to have a dynamic correction that can be slightly accommodated to the different components and working environment.

The point of this brief chapter is that there is often a generous operating temperature for every module. For ours, it’s roughly between 30 and 50 °C, which might translate to a panel temperature of 15-30 °C. It is thus important to let the modules warm up and play them in a reasonable temperature: do not play them under direct sunlight, or on a cold winter night on top of the Alps, or inside a pizza oven.

SUGGESTED READINGS

- Bernstein, David W. *The San Francisco Tape Music Center. 1960s Counterculture and the Avant-Garde*. Berkeley: University of California Press, 2008.
- Bjorn, Kim. *Patch & Tweak. Exploring Modular Synthesis*. Copenhagen: Bjooks, 2018.
- Bode, Harald. "History of Electronic Sound Modification." *AES: Journal of the Audio Engineering Society* 32, no. 10 (1984).
- Chowning, John M. "The Synthesis of Complex Audio Spectra by Means of Frequency Modulation." *AES: Journal of the Audio Engineering Society* 21, no. 7 (1973): 526–34.
<https://web.eecs.umich.edu/~fessler/course/100/misc/chowning-73-tso.pdf>
- Hordijk, Rob. "Designing Instruments for Electronic Music." *EContact!* 17, no. 4 (2016).
https://econtact.ca/17_4/hordijk_design.html
- Horowitz, Paul. *The Art of Electronics*. Third edition. New York: Cambridge University Press, 2019.
- Hutchins, Bernard A. 1975. "Frequency Modulation Spectrum of an Exponential Voltage-Controlled Oscillator." *AES: Journal of the Audio Engineering Society* 23, no. 3 (1975): 200–206.
- Meyer, Chris. "Understanding the Differences Between Exponential, Linear, and Through Zero FM." Published on the website *Learning Modular* on Mar 13, 2018. Last access: Nov. 30, 2021.
<https://learningmodular.com/understanding-the-differences-between-exponential-linear-and-through-zero-fm/>
- Roads, Curtis. *The Computer Music Tutorial*. Cambridge, MA-London, 1996.
- Shapiro, Peter. *Modulations. A History of Electronic Music. Throbbing Words on Sound*. New York: Caipirinha Productions, 2000.
- Strange, Allen. *Electronic Music: Systems, Technics, and Controls*. Second edition. Dubuque: Brown, 1984.
- Wells, Thomas. *The Technique of Electronic Music*. Second edition. New York-London: Schirmer Books-Collier MacMillan, 1981.

INTERFACES

Here at Frap Tools, we put a lot of effort into designing a proper user interface for each of our modules.

By “proper user interface” we mean essentially three things:

1. it must convey the module’s identity at a glance;
2. it must allow for a smooth creative workflow;
3. it must be pleasant to look at.

Moreover, we want our interfaces to be clear, but not self-explanatory (or, in other terms, cryptic, but not chaotic).

The reason for doing so is that, in our vision, the musician should master the “code” of the instrument before playing it: a piano does not have the note names on its keys, a violin does not have marks on its neck — it is up to the musician to practice and learn how the instrument works.

In the same way, our modules do not have labels such as ‘frequency’ or ‘decay time’: instead, they are replaced with a system of symbols and colors that try to be as consistent as possible. Moreover, a musician approaching our modules through a “conventional” labeling system might be tempted to assume that the module behaves in an ordinary way, which sometimes is not completely correct.

The modules are explained in detail further in this manual. However, to allow the musician to get acquainted with the overall symbol system, we provide here a brief guide to “decode” the most recurrent elements of the “Frap environment”.

1 ARROWS (INPUT, OUTPUT)

An arrow can mean either an input or an output, according to its position: if it points towards one or more jack sockets, it is an input; if it points away from one or more jack sockets, it is an output.

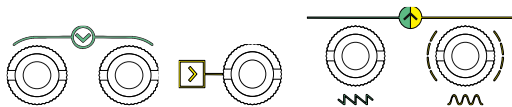

Figure 10: Arrows.

2 SQUARE AND ROUND SHAPES

The whole modular world revolves around voltage. The most basic distinction is, conventionally, between voltage used for timing pulses (triggers or gates) and voltage used for audio signals or CV.

The former is a discrete signal with two levels only (“off” and “on”, “low” and “high”). In our modules it is associated with square shapes: the reason is that squares have only two kinds of lines (vertical and horizontal), the same way a gate or rig signal has only two possible states, on and off.

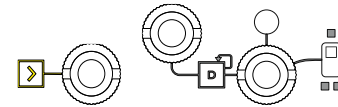

Figure 11: Square shapes.

The latter is a continuous signal (or ‘analog’ in its closest meaning). Is associated with round shapes because circles can be thought of as having infinite sides, the same way an analog signal has infinite values.

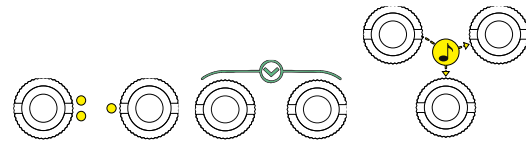

Figure 12: Round shapes.

A subgroup of the audio analog section is stereo audio. As you can notice in the CGM series, the group and master modules feature stereo in and out: here, the left/mono is connected to the solid-colored area, while the right is connected to the ring that surrounds it. The reason is that the left output is always the primary (because it can be used as a mono output as well), while the right one is more of an accessory to it.

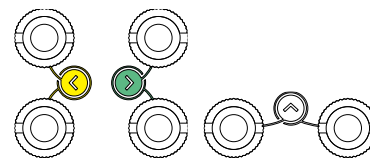

Figure 13: Stereo audio.

3 LINES (SOLID, DOTTED, DASHED)

A solid line relates two or more elements of the circuit. It stands for manual control, which means that a given knob or switch directly affects the signal passing through the circuit from an input or to an output.

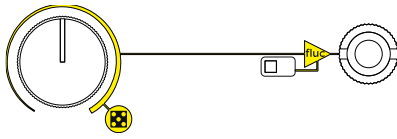

Figure 14: Solid lines.

A dotted line stands for external CV control, and it often relates a jack socket to a manual control such as a knob or a slider. It means that the specific parameter can be voltage controlled.

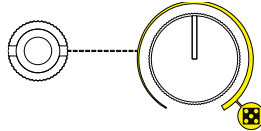

Figure 15: Dotted lines.

A dashed line relates two or more inputs or two more outputs: it means that they are semi-normalled, or, in other terms, that the signal going to one input or coming from one output is mirrored by the other jack sockets connected by a dashed line. Such behavior is automatically overridden once a cable is plugged into another jack socket (thus “breaking” the normalled connection).

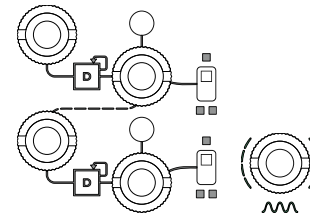

Figure 16: Dashed lines.

4 COLOR CODING

As a rule of thumb, if a module performs more than one function, the respective controls are marked with different colors. In other words, a given color relates to one and only one section of the module design. In case a module features two “mirrored” sections (such as SAPÈL’s or FALISTRÌ’s generators, or CGM Group’s FX sends), they are marked in yellow and green.

5 COMBINATIONS

All the elements can be combined. For example, an arrow within a square pointing towards a jack socket means that it is a gate/trigger input; if a dotted line connects a jack socket to a knob, and a solid line connects the same knob to another jack socket, it means that the signal outputted from the second jack socket can be modified either manually via the knob or automatically via an external CV patched to the first socket.

CGM – CREATIVE MIXER SERIES

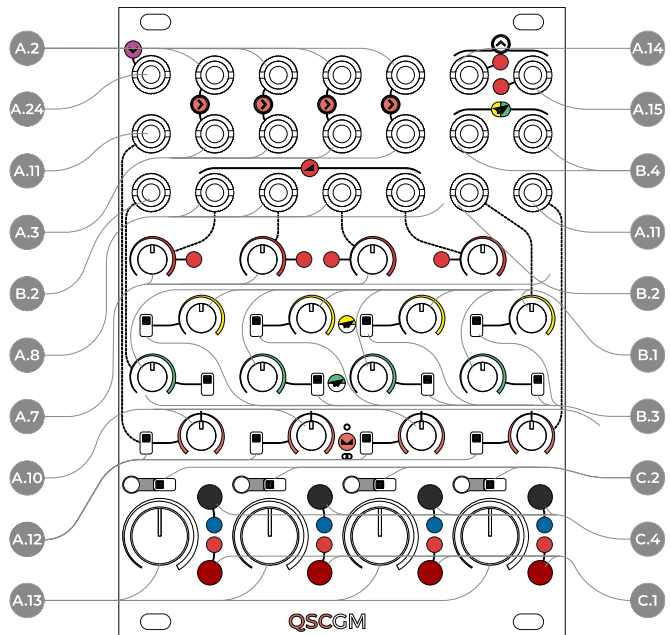
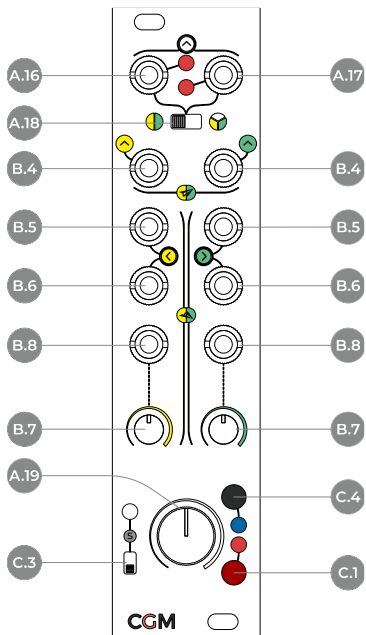
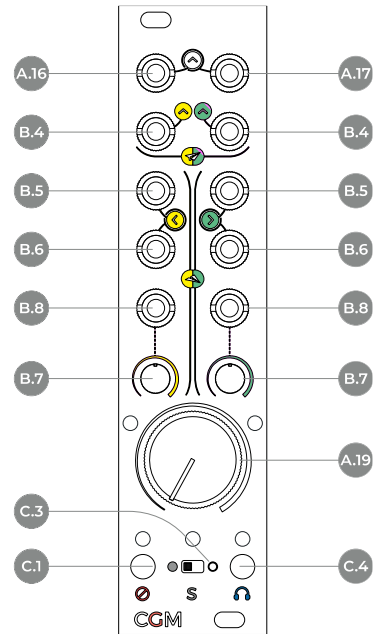
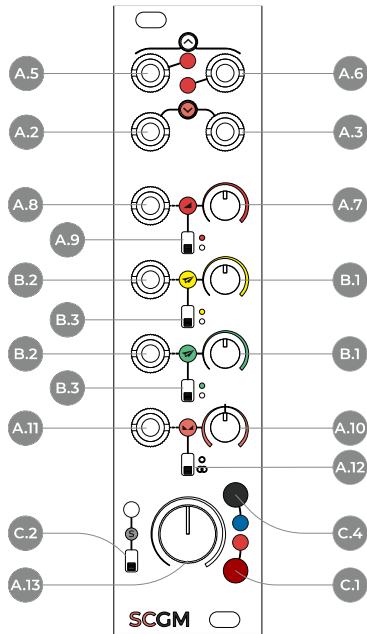
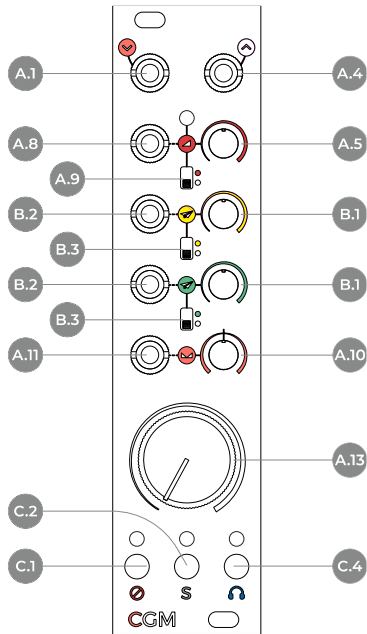

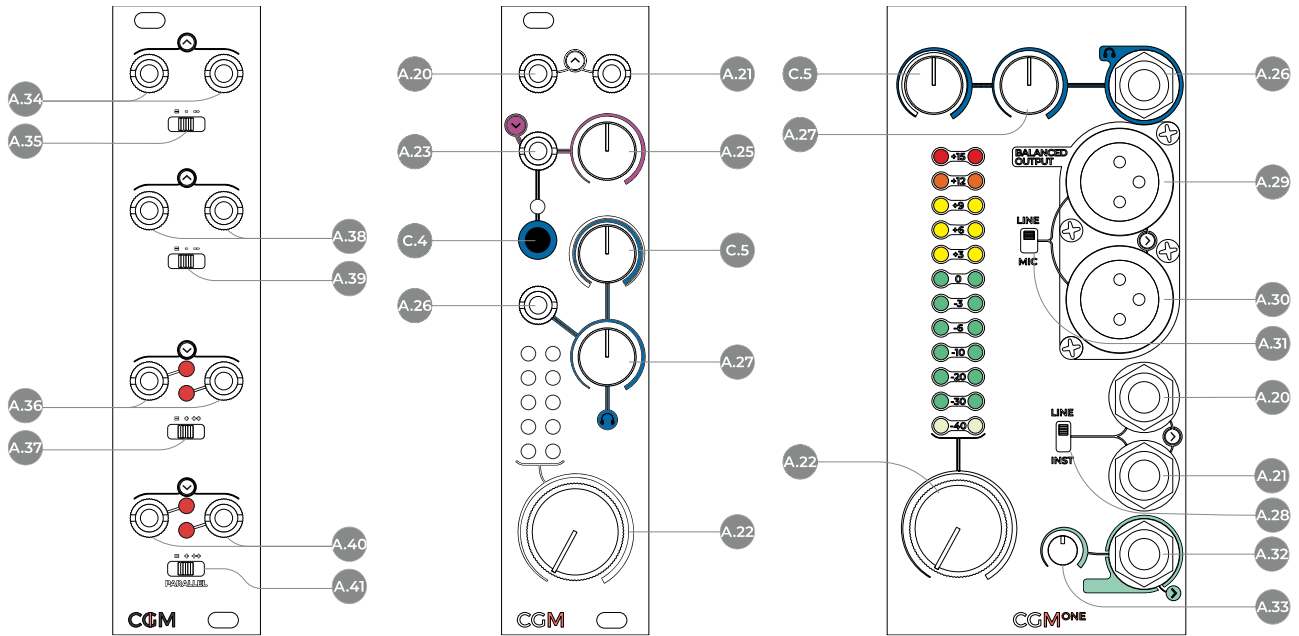

Figure 17: CGM Interface

A Main Audio Routing

- A.1 Audio Mono Input
- A.2 Audio Input Left/Dual Mono
- A.3 Audio Input Right/Dual Mono
- A.4 Direct Out
- A.5 Direct Out Left/Mono
- A.6 Direct Out Right
- A.7 VCA Level
- A.8 VCA Level CV Input
- A.9 VCA Pre/Post
- A.10 Pan Level
- A.11 Pan Level CV
- A.12 Pan/Crossfade Switch

- A.13 Channel Fader
- A.14 Local Output Left
- A.15 Local Output Right
- A.16 Group Output Left
- A.17 Group Output Right
- A.18 Group Output selector
- A.19 Group Fader
- A.20 Master Output Left
- A.21 Master Output Right
- A.22 Master Fader
- A.23 Aux. Stereo Input
- A.24 Aux. Mono Input
- A.25 Aux. Input Level
- A.26 Phones Stereo Output
- A.27 Phones Level
- A.28 Line/Inst Switch

- A.29 Balanced Output Left
- A.30 Balanced Output Right
- A.31 Line/Mic Switch
- A.32 Mono Out
- A.33 Mono Out Fader
- A.34 Insert Stereo Out
- A.35 Insert Output Gain
- A.36 Insert Stereo In
- A.37 Insert Input Gain
- A.38 Parallel Stereo Out
- A.39 Parallel Output Gain
- A.40 Parallel Stereo In
- A.41 Parallel Input Gain
- B Send/Return**
- B.1 Effect Send Level
- B.2 Effect Send Level CV
- B.3 Effect Send Pre/Post

- B.4 Effect Send Mono Output
- B.5 Effect Return Left Input/Dual Mono
- B.6 Effect Return Right Input/Dual Mono
- B.7 Effect Return Level
- B.8 Effect Return Level CV
- C Creative Functions**
- C.1 Mute Button
- C.2 Solo-In-Place Button/Switch
- C.3 Safe Solo Switch
- C.4 Pre-Fader Listen (PFL) Button and LED
- C.5 PFL Blend

1 PHILOSOPHY AND DESIGN

The CGM Creative Mixer is a modular solution system for Eurorack systems that blends the professional audio quality of studio consoles with many voltage-controllable parameters.

It breaks down the main parts of a classic mixer console into three families of modules (*channel*, *group*, and *master*) that you can purchase individually and link together to build the exact mixer you need. In addition, you can expand or shrink the setup as your musical demands change.

The CGM works by connecting the channel modules to the group modules and the group modules to a master module. Once the system is connected, the channels,

group, and master share audio, power, and controls like a single, organic device.

Please note that it is not possible to connect a channel module straight to a master one! However, if you want to keep your setup light and compact, it is possible to use a group module as an output section. Please refer to the following section for further details.

It is currently composed of five modules: the Stereo Channel, the Quad Stereo Channel, the Group, the Masterone, and the Insert. Three modules are now discontinued: the Channel, the 2016 version of the Group, and the Master.

2 THE LINK SYSTEM

Some CGM modules, like the QSC, can efficiently work as standalone units. However, they unlock their full potential when connected to other units to build a complex mixing console: the CGM works by linking (up to eight) channels to a group, and (up to four) groups to a master via 10-pole IDC plugs on each module's PCB.

Here's an example of the largest possible configuration. If the channel modules are QSCs, this setup leads to a 128-channel mixing desk.

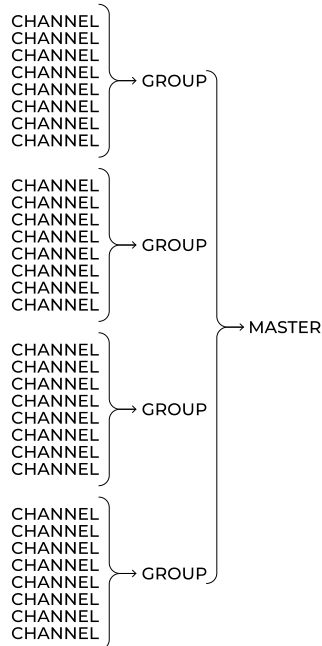

Figure 18: CGM structure.

A channel-group configuration can efficiently work without a master (you can use the group stereo outs as your main outputs). Still, neither a channel-master configuration (without a group) nor a group-master configuration (without a channel) would work.

For this purpose, we designed a unique set of connecting cables named *Link System*, which replaces the older *Link Cables* (now discontinued but still compatible with newer products).

There are three kinds of cables in the new Link System:

- group-to-channel cable;
- master-to-group cable;
- group-to-group extension.

This section will describe how to connect channels, groups, and masters, in the classic CGM configuration. The Insert module is a sort of break in the audio path that can be installed in various points, and for this reason it will be discussed in its dedicated section [7](#).



Watch the assembly instructions with many configuration examples in the following video: [How to Build a Frap Tools CGM Eurorack Mixer Setup](#)

2.1 LINKING GROUPS AND CHANNELS

The first step to building a CGM configuration is connecting channels to a group. This connection happens through two special *group-to-channel* cables with 10-pole IDC sockets: connect the two rows of pin headers on the back with the two pin headers in the same position on the group's PCB.

The GC sockets are spaced so that they can accept modules up to 18 HP wide. For a better fitting, we recommend folding the cables in a Ω shape.

All the channels share audio, power, and controls when connected to a group, so it is sufficient to connect to the PSU just one channel of those linked to such a group.

The GC Link System comes in three different sizes:

F-G1C2-LS	CGM Link System – 1 Group to 2 Channel Modules
F-G1C4-LS	CGM Link System – 1 Group to 4 Channel Modules
F-G1C8-LS	CGM Link System – 1 Group to 8 Channel Modules

Every group module ships with a 1-group-to-2-channels cable, and it's ready to be connected to a channel (the channel ships with no cables except for the power ones). If you plan to connect more than two channels to a group, you may want to purchase a 4- or 8-channel cable separately.

2.1.1 Older Group-to-Channel Link Cables

When the channels were all 6 HP wide, there were eight kinds of *Link cables*, connecting a group to 1, 2, 3, 4, 5, 6, 7, and 8 Cs, respectively. The socket spacing was tailored to 6 HP, so the introduction of the QSC made a redesign necessary.

If you still have some older Link cables, you can use them easily with newer products, even if some plugs will inevitably end up being unused.

2.2 LINKING MASTERS AND GROUPS

There are two cases in which you may need to connect groups and masters: expand the functionalities of a single group or mix more groups. There are two Link System parts for this purpose: a strip and its extension, one for each use.

By default, the Masterone ships with a *master-to-group* cable, allowing you to link a group to it. The *master-to-group* cable has three IDC connectors: one for the master, one for the group, and one for extending the connection to other groups.

To connect more than one group, you need the *group-to-group* extension. This cable has two IDC sockets and one IDC plug. Connect the plug to the third *MG* socket, and you'll be able to link two more groups to a master. The *group-to-group* sockets are spaced to accept group configurations of roughly 72 HP, allowing up to 4 QSCs.

It is possible to chain more GG extensions to one another, such as for adding a fourth group or connecting groups with larger channel configurations (up to eight QSCs).

The *master-to-group* cable ships with the Masterone and cannot be purchased separately. The *group-to-group* extension is sold separately with the following code:

F-G2GX-LS CGM Link System – Group-to-Group Extension

2.2.1 Older Master-to-Group Link Cables

The previous way of connecting groups and masters, part of the *Link Cables*, consisted of four configurations that allowed you to connect a master to 1, 2, 3, or 4 groups, respectively.

The sockets' spacing could fit up to 8 mono channels per group.

The M module used to ship with a link cable to one group, and the G module with link cables to four channels.

Anyway, both the older Link Cables and the new Link System follow the same logic and are entirely swappable. So, if you have older cables, feel free to use them with the new CGM modules and the new Extension: just make sure to follow the connection rules.

If you accidentally connect more than one Channel to the PSU, fear not: it's not going to damage your system! It's just useless and may not be optimal for grounding.

It is imperative not to swap connectors! Frap Tools may not be held responsible in any way for problems or damage to persons or property or to the device itself if the device is not connected as indicated above.

Remember: it is not possible to connect a channel to a master module! You always need a group between them.

3 STEREO CHANNEL

The SC module replaces the C as the most feature-rich single-channel module.

It retains all the features and CV inputs of the C but stereo, and it also includes the *Pan/Crossfade* function of the QSC.

The signal routing matches the CGM quality standard and can be broken down into five color-coded main parts: VCA (red), two effect sends (yellow and green), pan (pink), and fader (white).

3.1 AMPLITUDE CONTROLS AND DIRECT OUTPUTS

The signal flow starts with the two channel inputs ([A.2](#), [A.3](#)). Next, the main VCA defines the initial gain of the signal patched to them through the *Level* knob ([A.7](#)). Next, the *Channel Fader* ([A.13](#)) sets the audio signal's volume to be sent to the G module.

In other words, the VCA controls the amplitude of the signal coming in, and the fader controls the amplitude of the signal going out.

These two controls together, just like in classic mixing consoles, allow you to define not only the amplitude of the signal in the mix but also its “color.”

The input VCAs goes above unity gain, which means that it can add a very smooth saturation to the incoming sound, often translated to adjectives such as “fatter, punchier, warmer.”

Furthermore, such input level can be voltage-controlled through the *VCA Level CV Input* ([A.8](#)). When a signal is patched to this input, the *Level* knob ([A.7](#)) becomes its attenuator.



Practice the *VCA Level CV Input* with this Technique:
[Sidechain #1](#)

The main VCAs also feature a mono/stereo *Direct Output* ([A.5](#), [A.6](#)), which allows you to take the incoming signal after it has been amplified (or colored) by the VCA. It is beneficial in the case of multitrack recording or parallel processing.

For this purpose, the *Direct Out* has a *Pre/Post Switch* ([A.9](#)), which lets you define if it should work pre-fader (upper position, red dot) or post-fader (lower position, white dot).

If set pre-fader, the signal coming out of the *Direct Output* will be straight after the main VCA, regardless of the *Channel Fader* position ([A.13](#)). If it is set post-fader, its amplitude will also be determined by the channel fader and will thus mirror the presence of the signal in the final mix.

The left direct output ([A.5](#)) can also work as a mono sum: when nothing is patched to the right input, it

outputs the sum of both channels. However, the semi-normalled connection breaks when a cable is patched to the right output ([A.6](#)). At this point, the two outputs begin to work in stereo.

Thanks to this, the SC offers a flexible signal routing between its inputs and outputs: it can work in stereo, mono, mono-to-stereo, stereo-to-mono, and dual mono.

3.1.1 Stereo Behavior

This is the most straightforward use of the SC. First, patch a stereo channel to the left and right inputs ([A.2](#), [A.3](#)): the signals will be internally routed to the group. Then, you can patch two cables to the left and right direct outputs to obtain a copy of the signal, either pre or post-fader.

3.1.2 Mono Behavior

Patch a mono source to either the left or right input ([A.2](#), [A.3](#)) to use the SC as a traditional mono channel. In this case, the left direct output ([A.5](#)) will work like the C's direct output ([A.4](#)), thus ignoring the stereo position.

3.1.3 Mono-to-Stereo Behavior

If you want to record a mono source that moves between left and right and track its stereo position, you can patch both the left and right direct outputs to your recording equipment.

This operation is now possible for the first time on the CGM since the original C's panpot affected only the sound routed to the G module.

3.1.4 Stereo-to-Mono Behavior

The left direct output ([A.5](#)) outputs the mono sum of both channels patched to the left and right inputs ([A.2](#), [A.3](#)).

3.1.5 Dual mono

The SC also features the mono/crossfade switch that allows you to use it as a dual mono mixer. Read more on this topic in the Crossfade section ([§3.3.1](#)).

3.2 EFFECT SENDS

The two *Send Level* knobs ([B.1](#)) define the amplitude of the channel signal to be routed to the group's effect sends mono outputs ([B.4](#)).

Just like the Main VCA, they can be voltage controlled by patching unipolar CVs to its CV input ([B.2](#)). This input allows you to automate the effects of each channel individually in a way that is not possible on standard mixing consoles.

Both the effect sends are equipped with a *Pre/Post Fader* switch ([B.3](#)). If it is set post-fader (lower position, white dot), the signal sent to the external effects will be limited by the channel fader position ([A.13](#)). This option is useful

when you want your dry/wet signal ratio always the same when you adjust a channel's volume.

If set pre-fader, the effect send will be defined by the knob or the CV only, thus being completely independent of the overall channel level. In this way, you can achieve some effects such as lowering the channel fader and leaving just the processed signal in the mix.

Another way of looking at the pre/post effect send is that the former is an absolute level, while the second one is relative (to the main fader, in this case).

3.3 PAN

When the Pan/Crossfade switch ([A.12](#)) is set to the lower position, the knob ([A.10](#)) acts as a stereo panorama control, defining the balance of the (mono or stereo) audio input across the left and right channels.

Two CV inputs ([A.11](#)) allow for external control of the leftmost and rightmost channels' Pan with positive and negative voltages. The more the positive CV increases, the more the signal is distributed to the right, and vice versa for negative CVs and the left channel.

Given that the Pan is a bipolar control, the CV input works slightly differently than the VCA and the effect Sends. In this case, when a CV is patched to its input, the knob shifts the incoming CV towards the positive (right) or negative (left) side. In other words, it acts as an offset, not an attenuator.

3.3.1 Crossfade

When the Pan/Crossfade switch ([A.12](#)) is set to the higher position, the knob works as a "dual mono" crossfade that blends the signals patched to the two inputs and outputs the same result across the left and right channel.

It can be helpful, for example, for blending the sound of two waveform outputs of the BRENSO oscillator (see p. [109](#)) for a punchier, mono bassline, or mixing two elements of a drum pattern that do not need to be panned across the stereo image.



Practice the *Pan/Crossfade* functions with this Technique:
[Pan/Crossfade #1](#)
[Pan/Crossfade #2](#)

3.3.1.1 Direct Outputs Behavior in Crossfade Mode

When using the SC in Crossfade mode, the direct outputs retain their semi-normalled behavior: if the left output is used as mono out, it sums the left and right channels and lets you hear the crossfade. If, however, a cable is patched to the right direct output, the two outputs become stereo again, thus working as if the channel were still set to Pan.

Besides this, the signal routed to the group is still mono.

3.4 CREATIVE FUNCTIONS

Every channel has three creative controls: the *Mute* button ([C.1](#)), the *Solo in Place* ([C.2](#)), and the Stereo PFL (Pre-Fader Listening, [C.4](#)).

3.4.1 Mute

The *Mute* button ([C.1](#)) closes the main VCA. Thus, it equals turning the VCA Level knob ([A.7](#)) all the way to zero. For this reason, muting a channel allows you to mute all of its outputs, including the effect sends.

3.4.2 Solo in Place

The *Solo in Place* button ([C.2](#)) selects the channels to keep active when the group is in *Safe Solo* mode ([C.3](#), see below [§6.4.2](#)).



Practice the *Safe Solo* with this Technique:
[Safe Solo](#)

3.4.3 PFL

The *Stereo PFL* button ([C.4](#)) selects the channels sent to the *PFL* circuit on the *Master* module ([C.5](#), see below [§6.4.3](#)).

4 QUAD STEREO CHANNEL

The Quad Stereo Channel (QSC) consists of four stereo channels, with a design based on the Channel (§5) module that, however, also borrows some concepts from the G (§6) and the M (§9) modules. The color scheme reflects the exact routing of the modules: VCA (red), two effects sends (yellow and green), pan (pink), auxiliary input (purple), and main faders (white).

The local sum outputs also allow you to use the QSC as a standalone stereo mixer with mono effect sends. The panning section can switch its behavior between stereo source panning and mono sources crossfading.

4.1 AMPLITUDE CONTROLS AND LOCAL OUTPUT

The main VCAs define the input gain of the signal patched to the channel inputs (A.2, A.3) through the *Level* knob (A.7). The *Channel Faders* (A.13) set the audio signal's volume to be sent to the *Group* module. Like in the Channel module, the VCA controls the signal's amplitude coming in, and the fader controls the signal's amplitude going out.

These two controls together, just like in classic mixing consoles, allow you to define not only the amplitude of the signal in the mix but also its “color.”

The input VCA goes ~6dB above unity gain, which means that it can add a very smooth saturation to the incoming sound, often translated to adjectives such as “fatter, punchier, warmer,” and so on.

Furthermore, such input level can be voltage-controlled through the *VCA Level CV Input* (A.8). When a signal is patched to this input, the *Level* knob (A.7) becomes its attenuator.



Practice the *VCA Level CV Input* with this Technique: [Sidechain #1](#)

One of the differences between the QSC and the C is that it features a local stereo output (A.14, A.15) instead of individual Direct outputs (A.4). This allows you to use the QSC as a standalone, four-channel stereo mixer.

4.1.1 Mono Auxiliary Input

The QSC also features an additional monophonic DC-coupled input (A.24). This is an audio input with no controls over the signal's amplitude, and its signal routing is very straightforward, adding the sound as is to the overall sum routed to the Group or the two local outputs (A.15, A.16).

The Mono Auxiliary input can be helpful if you need a spare mono channel for an external source that does not need further amplitude processing.

4.2 EFFECT SENDS

The two *Send Level* knobs (B.1) define the amplitude of the channel signal to be routed to the Group's effect sends mono outputs (B.4).

All the effect sends are equipped with a *Pre/Post Fader* switch (B.3), which improves the module's usability. If set post-fader (lower position, white dot), the amount of signal sent to the external effects will be limited by the channel fader position (A.13). This option is useful when you want your dry/wet signal ratio to be always the same when you adjust a channel's volume.

If set pre-fader, the effect send will be defined by the knob or the CV only, thus being completely independent from the overall channel level. In this way, you can achieve some effect such as lowering the channel fader and leaving just the processed signal in the mix.

Another way of looking at the pre/post effect send is that the former is an absolute level, while the second one is relative (to the main fader, in this case).

The green send of the leftmost channel and the yellow send of the rightmost channel can be voltage controlled by patching unipolar CVs to their CV input (B.2).

The QSC is equipped with two local effects mono outputs (B.4), one for the yellow and one for the green sends. They work like the group mono send, outputting the sum of the signals defined by the four channels' send knobs.

These outputs allow you to take advantage of the mono sends even if you have a smaller system without a group.



Practice the local sends with this technique: [Reverb Feedback #2](#)

4.3 PAN AND CROSSFADE

The *Pan/Crossfade* knob can perform two different tasks according to the Pan/Crossfade switch position.

4.3.1 Pan

When the Pan/Crossfade switch (A.12) is set to the lower position, the knob (A.10) acts as a stereo panorama control, defining the balance of the (mono or stereo) audio input across the left and right channels.

Two CV inputs (A.11) allow for external control of the leftmost and rightmost channels' Pan with positive and negative voltages. The more the positive CV increases, the more the signal is distributed to the right, and vice versa for negative CVs and the left channel.

Given that the Pan is a bipolar control, the CV input works slightly differently than the VCA and the effect Sends. In this case, when a CV is patched to its input, the knob shifts the incoming CV towards the positive (right)

or negative (left) side. In other words, it acts as an offset, not an attenuator.

4.3.2 Crossfade

When the Pan/Crossfade switch ([A.12](#)) is set to the higher position, the knob and the CV inputs work as a “dual mono” crossfade that blends the signals patched to the two inputs and outputs the same result across the left and right channels.

It can be helpful, for example, for blending the sound of two waveform outputs of the BRENSO oscillator (see p. [109](#)) for a punchier, mono bassline, or mixing two elements of a drum pattern that do not need to be panned across the stereo image.

Setting all the stereo channels to Crossfade can even let you use the QSC as an almost-eight-channel-mono mixer.



Practice the *Pan/Crossfade* functions with this Technique:
[Pan/Crossfade #1](#)
[Pan/Crossfade #2](#)

4.4 CREATIVE FUNCTIONS

Every channel has three creative controls: the *Mute* button ([C.1](#)), the *Solo in Place* ([C.2](#)), and the Stereo PFL (Pre-Fader Listening, [C.4](#)).

4.4.1 Mute

The Mute button ([C.1](#)) closes the main VCA. Thus, it equals turning the VCA Level knob ([A.7](#)) all the way to zero. For this reason, muting a channel allows you to mute all of its outputs, including the effect sends.

4.4.2 Solo in Place

The *Solo in Place* button ([C.2](#)) selects the channels to keep active when the group is in *Safe Solo* mode ([C.3](#), see below [§6.4.2](#)).



Practice the *Safe Solo* with this Technique:
[Safe Solo](#)

4.4.3 PFL

The *Stereo PFL* button ([C.4](#)) selects the channels sent to the *PFL* circuit on the *Master* module ([C.5](#), see below [§6.4.3](#)).

5 CHANNEL (DISCONTINUED)

The C module was the first member of the channel family. Its concept drew from the monophonic channel of a classic mixing console. The crucial implementation of CV controls over every key parameter made it entirely suitable for the Eurorack environment.

The signal routing was designed to provide the best audio quality and can be broken down into five color-coded main parts: VCA (red), two effect sends (yellow and green), pan (pink), and fader (white).

5.1 AMPLITUDE CONTROLS AND DIRECT OUTPUT

This section has the same core features of the SC's one but mono. Refer to §3.1 for a detailed description, without all the extra features derived from the stereo routing.

The main VCA defines the input gain of the signal patched to the channel input (A.1) through the *Level* knob (A.7). The *Channel Fader* (A.13) sets the audio signal's volume to be sent to the G module. The *VCA Level CV Input* (A.8) allows you to voltage-control the VCA level.



Practice the *VCA Level CV Input* with this Technique:
[Sidechain #1](#)

A *Direct Output* (A.4), which allows you to take the incoming signal after it has been amplified (or colored) by the VCA, either pre or post-fader (A.9).



Practice the use of the *Direct Output* with these Techniques:
[FUMANA Feedback #1](#)
[FUMANA Feedback #2](#)
[FUMANA Feedback #3](#)

5.2 EFFECT SENDS

This section is identical to the SC's one: please refer to §3.2 for further details.

The two *Send Level* knobs (B.1) define the amplitude of the channel signal to be routed to the group's effect sends mono outputs (B.4). It features a CV input (B.2) and a pre/post fader switch (B.3).

5.3 PAN

The *Pan* control lets you distribute the processed signal across the stereo image through the Pan knob (A.10).

This parameter is provided with a CV input (A.11), which accepts both positive and negative signals.

The Pan is a bipolar control, so the CV input works slightly differently from the VCA and the effect Sends. In this case, when a CV is patched to its input, the knob

shifts the incoming CV towards the positive (right) or negative (left) side. In other words, it acts as an offset, not an attenuator.

5.4 CREATIVE FUNCTIONS

Every channel has three creative controls: the *Mute* button (C.1), the *Solo in Place* (C.2), and the Stereo PFL (Pre-Fader Listening, C.4), on which see §§ 3.4.1, 3.4.2, and 3.4.3 above.

6 GROUP

The Group is a stereo module that blends the signals from the channels linked to it (up to eight) and manages their signal routing.

The group “puts into practice” all the information defined by the channel’s controls: volume, effect send volume, stereo panning.

It consists of three sections: the amplitude controls (white) and the two effect sends and returns (yellow and green).

After receiving and summing the channels’ signals and their effect returns, the group routes the sum to the master module (if present) and its group outputs. The two jacks can output either the sum of the channels and the effect sends or just the effect sends.

The current G module is an updated version of the now-discontinued 2016 G. Its functions are the same as the old one, but it features significant design upgrades that improve its usability: the selectors for the group output’s behavior are now on the front panel, and the knob is now 12 mm in diameter, like the new SC and QSC.

As of today, the Group is the only module that does not require power, as a Channel powers it through its IDC cable.

6.1 AMPLITUDE CONTROL

The primary control is the *Group Fader* (A.19), which sets the Group’s final volume. This is the overall amplitude of the sum of the connected channels and the returns.

It features a pair of peak LEDs on the top left and right of the knob that notifies when the left or right Channel (respectively) are clipping.

6.2 EFFECT SENDS/RETURNS

This section of the module is the CGM interface for external signal processing. It consists of two specular sections, marked yellow and green, each featuring a mono output (Send) and a stereo input (Return).

6.2.1 Sends

The *Send* jack socket (B.4) outputs a mono signal, the sum of all the signals processed for that send by each Channel connected to the Group.

6.2.2 Returns

The *Return* section is divided into two specular columns, the left one for the yellow return, the right one for the green return.

The first two rows from the top are the *Return* inputs (B.5, B.6). They are semi-normalled, meaning that they can work either in stereo (when two cables are plugged) or in dual mono (when only one cable is plugged into any of the two inputs). When using two cables for stereo

return, the top jack carries the left signal and the bottom jack the right one.

As soon as an audio signal is connected, it is routed to the stereo return: each *Return* section is equipped with its stereo VCA, which is identical to the ones used in the red, yellow, and green sections of the *Channel* module. To control the amplitude of the effect return, use the Return Level knob (B.7).

The return level can be externally controlled through the CV inputs (B.8), allowing any creative use of the stereo effect returns. When a CV is patched to any of these inputs, the *Level* pot (B.7) acts as an attenuator.



Practice the *Send/Return* modulation with this Technique: [Sidechain #1](#)

6.3 GROUP OUTPUTS

Every group has two *Group Outputs* that are stereo paired (A.16, A.17). The *Group output selector* (A.18) on the front panel lets you configure them to output just the sum of the processed signals (from the stereo returns) or the overall sum of the channels and effects.

When the switch is set on the left, the output signal is the effects return only: this mode is excellent for multi-track recording or advanced parallel processing.

When the switch is on the right, they output the same signal routed to the Master module: a sum of all the channels, plus the yellow and green effect return. This mode is handy for smaller setups, where a Master module is not needed because it allows you to use the Group module as your final mixing unit.

6.3.1 G 2016 Jumpers Configurations (DISCONTINUED)

In the older G module, now discontinued such a change was made through two jumpers on the PCB.



Figure 19: Pins 1 and 2.



Figure 20: Pins 2 and 3.

To set the first mode, place the two jumpers on the back of the PCB to pins 1 and 2 from the left (Figure 19).

To set the second mode, place the two jumpers on the back of the PCB to pins 2 and 3 from the left (Figure 20).

Any of these jumper configurations will not affect the signal routed to the Master module via IDC cable.

It is imperative not to connect the jumpers to any other connector except the two mentioned in this section and shown in the pictures below. Frap Tools may not be held responsible in any way for problems or damage to persons or property or to the device itself if the device is not connected as indicated above.

6.4 CREATIVE FUNCTIONS

Every Group has three creative controls: the *Group Mute* button (C.1), for all the connected Channels and send/return signals; the *Safe Solo* switch (C.3), which enables the *Solo In Place* function on each of the connected Channels when moved to the left, and the *Stereo PFL* (C.4), accessible via the *Master* module for all the connected Channels and *Send/Return* signals.

6.4.1 Group Mute

The Group Mute button (C.1) shuts the whole group, including the effect sends and returns. It equals turning the Group Fader (A.19) to zero.

Please note that the group outputs won't be affected by the mute button: to take advantage of the Group Mute function, the group needs to be routed to a master module, and the audio taken from this last one.

6.4.2 Safe Solo

The *Safe Solo* function allows the musician to isolate specific channels in the mix, thus muting all the remaining ones. It is achieved through two operations: pushing the *Solo in Place* button on the *Channel* module and moving the *Safe Solo* switch on the *Group* module. The *Solo in Place* button will determine which channels will be soloed (marked with the white LED) and which ones muted; the *Safe Solo* switch will put this selection into practice (and the group too will display a white LED). It is called *Safe Solo* because it safely allows you to select the channels you want to solo in advance without affecting the ongoing performance.



Practice the *Safe Solo* with this Technique:
[Safe Solo](#)

6.4.3 PFL

The *Stereo PFL* button (C.4) allows you to prelisten the group when it is muted or when its fader is set to the lowest position. To take advantage of this function, you need to connect the group to a master module with its PFL Blend (C.5, see below §8.2.2).

7 INSERT

The insert module allows you to connect stereo effects to your CGM setup, either by inserting them between two points of the internal summing bus or by placing them in parallel, as in a rudimentary stereo send-and-return.

It consists of two couples of outputs and inputs with dedicated gain switches. The first O/I stereo couple is the *insert* circuit, while the second is the *parallel* circuit.

The Insert module can be used:

- between a group and a master;
- between a group and a group;
- between a channel and a group;
- between a channel and a channel;
- between a channel and a master (without a group).



Watch the video tutorial here:
[CGM Insert Overview & Tutorial](#)

7.1 POWER

The Insert module has a standard Eurorack power socket, but it is not always necessary to use it. It becomes necessary only when the insert module is placed after a group. Conversely, when placed after a channel, the Insert draws power from it just like a regular group.

7.2 POSSIBLE CONFIGURATIONS

There are six 10-pole IDC plugs on the back, but they serve different purposes and must not be used all at the same time. The connectors are arranged so that they are located exactly in the same spot as the previous and the following CGM modules in the chain.

The Insert comes with two short Link cables like those used to connect the Group to the Master: they should get you covered in most cases, and for other scenarios, you may purchase every Link System configuration.

Beware! Never connect the insert plugs between themselves. Never use the same cables from the inputs and the outputs. The insert module is a literal break in the CGM summing buses, so it requires separate cables from the input and the outputs.

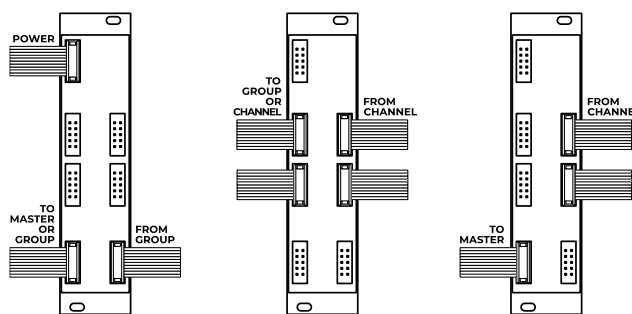

Figure 21: Insert connection types.

It is possible to have a multi-insert configuration, so more than one insert placed in series, after different groups, or after different channels, but one must pay attention to the gain staging, on which see below §7.4.

7.2.1 Group-Insert-Master

To insert the module between a group and the master, use the bottom plugs. Connect the group's IDC plug to the Insert's *From G* plug and use a separate cable to connect the *To M* socket to the master socket.

In this case, you must also connect the Insert module to the PSU through the boxed power plug.

In this scenario, the effects patched to it will equally affect all the group sums before it.

7.2.2 Group-Insert-Group

It is also possible to install the insert module earlier in the chain, for example between two groups of channels. In such a configuration, the effects patched in the insert will process only the groups before it, leaving the following group(s) untouched.

Even in this case, it is necessary to connect the Insert module to the PSU through the boxed power plug.

7.2.3 Channel-Insert-Group

The other main position for the insert module is after one or more channel modules, either QSC, SC, or the discontinued mono channel.

For this kind of connection, you must connect the channel sockets to the *From G* plug and the *To G* plug to the group plug using both cables that come with the Insert.

It is not necessary to connect the Insert to the PSU when using it after the channel modules since it can draw its power from them like a regular group.

When the Insert is placed between a channel and a group, the whole channel-group system retains its send/return and solo-in-place functionalities.

The yellow and green send/return pass through the insert and are not affected by whatever signal pa

7.2.4 Channel-Insert-Channel

It is also possible to install the Insert between two or more channels. Here, it will only affect the channels before it, leaving the following ones untouched.

By doing so, the Insert will create two sorts of channel sub-groups. The effect sends will retain their function whether the channels are before or after the insert, but the solo-in-place will work separately in each sub-group. In other words, the solo-in-place switch of the channels before the insert will not affect the channels after it, and vice-versa. It is thus possible to activate the Safe Solo function on a subgroup only, leaving the other one playing.

7.2.5 Channel-Insert-Master

Finally, it is possible to place the insert after one or more channels (up to 8) straight before a master module without a group. This solution is a bit limiting because it inhibits the functions of the CGM like the group's send and return, the Safe Solo, and the PFL, but it may be useful in smaller setups where the stereo insert and send/return have priority.

7.3 FUNCTIONS AND CONTROLS

The insert module performs two tasks: *insert* and *parallel*. The difference between them is that any signal patched to the *Insert* I/O replaces the internal CGM sound going out of the Insert module, while a signal patched to the *Parallel* I/O is summed to it.

7.3.1 Insert I/O

The proper *insert* function opens the circuit between what gets into the module and what gets out, allowing to put anything in between.

When nothing is patched, the all-analog signal flow makes the insert module almost non-existent, because the insert outputs ([A.34](#)) are semi-normalled to the insert inputs ([A.36](#)). To insert any effect, connect the insert output to the desired effects or effect chain, and then the effect or effect chain to the insert inputs.

As soon as you connect these last jacks, you will override the internal semi-normalled connection, and the signal going out of the insert module will now be the processed one.

7.3.2 Parallel I/O

The *Parallel* section allows you to connect a stereo signal on top of the main audio sum. It is useful when it is important to maintain a dry copy of the signal, like for adding stereo ambiance effects.

To do so, patch the parallel outputs ([A.38](#)) to your effects and the effects output to the parallel input ([A.40](#)).

Please note that the parallel section always picks the signals before the *Insert* section, so it will ignore whichever effect you patched to the *insert* input.

7.3.3 Gain Controls

This is the only control featured on the module, so it is crucial to familiarize yourself with it.

Every output and input has a three-position switch that defines its gain ([A.35](#), [A.37](#), [A.39](#), [A.41](#)). The outputs have three degrees of attenuation, while the inputs have three matching degrees of amplification.

In every input and output the leftmost position, labeled as =, is the most neutral solution, where the sound is not modified.

The middle position, labeled as - in the outputs and + in the inputs, halves the sound's amplitude when going out and doubles it when coming in.

The third position labeled as -- and ++, offers the highest possible attenuation over the outputs and the corresponding amplification over the inputs.

When nothing is patched, try experimenting with the insert switches ([A.35](#), [A.37](#)) over the semi-normalled connection: moving them by the same amount, so matching = with =, - with +, and -- with ++, will result in no discernible amplitude variation.

It is worth noting though that the most extreme positions will also cause the noise floor to be four times higher. It is no big deal since the CGM is pretty silent, but it is worth keeping this notion in mind and using these extreme settings only when needed.

The primary function of the switches is to preserve the unity gain without any unwanted overload of the external effects. If we have a compressor that is particularly sensitive to hot signals, we may attenuate the sound going out of the CGM and compensate when coming back in.

However, it is also possible to use them to deliberately alter our sound's amplitude. For example, we can attenuate the sound going out of the parallel output ([A.38](#), -) without compensating it at the parallel input ([A.40](#), =), so to keep our reverb back in the mix.

Or, we can keep the semi-normalled connection active, leave the insert output equal ([A.34](#), =), and then set the insert input to the maximum level ([A.36](#), ++) to saturate the summing stage.

7.4 A NOTE ON THE CGM'S GAIN STAGING

The CGM's open architecture implies that it is possible to connect many audio sources to it and obtain large configurations. It is thus mandatory for us to put particular care into preserving the mixer's headroom.

For this reason, every summing stage (like a group or a master) reduces the input by a few dB's, which then compensates afterward. This allows cleaner mixes and makes

the groups or master saturation possible only when deliberately needed.

Since most summing stages have knobs that can go way past the unity gain, this feature is almost irrelevant. With the insert module and its switch-based gain scale, though, we need to get more technical.

Conceptually, the = position is the one that preserves the purest gain staging, but from an electronic standpoint, it also preserves the -6 dB attenuation for headroom safety peculiar to every CGM summing stage.

So, even though the equal-out-equal-in behavior is the neutral one, it will ultimately translate into a gain reduction. In other words, if you put the insert between the group and the master in the neutral position, the sound will be 6 dB lower than without the insert.

We recommend this setting for the sake of headroom, especially after multiple groups or channels, but if you want to have a more electronically accurate behavior, at the cost of some potential distortion, you may leave the insert output to = and give it a six extra dB by setting the insert input to +. Knowing this feature might be especially helpful in setups that involve multiple insert modules in series.

The following table shows the absolute gain scale values of the Insert module.

	=	-/+	--/++
Output	-6,5 dB	-13 dB	-24 dB
Input	0 dB	+6,5 dB	+18 dB

Table 3: Insert gain scale (subject to 1 dB of tolerance)

8 MASTERONE

The Masterone replaced the Master module as the gateway from the modular system to the outside world. Following and expanding the Master concept, we designed it with the sole purpose of providing high-quality outputs in as many formats as possible. For this reason, since it is not meant to be connected to any other Euro-rack module, it is the only Frap module that does not have any 3.5 mm jack connection (as of today).

It consists of the amplitude control (white) and the Headphones/PFL section (blue). An additional mono output (light green) is part of the amplitude section.

Two arrays of 12 LEDs act as a stereo VU meter: they measure the amplitude increments from -40 to 15 dBu, with peak memory.

8.1 AMPLITUDE CONTROL

The primary control is the *Master Fader* (A.22), which sets the overall amplitude of the sounds coming from the connected groups. At this stage, it can add 6 dB of gain: it is thus possible to saturate the circuit to introduce distortion and nonlinearities in the sound.

The Master features two columns of 12 LEDs that act as a graphical VU-meter of the audio levels on the left and right channels.

The Masterone has three kinds of outputs: pseudo-balanced stereo TRS, balanced stereo XLR, and pseudo-balanced mono.

8.1.1 Pseudo-balanced TRS Outputs

These 1/4" jack outputs (A.20, A.21) are technically identical to ones on the Master module: they output an unbalanced (or pseudo-balanced, see below) stereo signal (left and right channels, respectively).

The line signal is at the Eurorack level¹⁰, so, in case it is too hot for some destinations, it is possible to attenuate it through the Line/Inst switch (A.28). Once the switch is set to the lower position, the output is attenuated by ~15dB.

Just like the Master outputs, these outputs are pseudo-balanced. If you use a standard 1/4" mono jack, you'll obtain an unbalanced output. If you patch a 1/4" TRS jack, you can connect them to a balanced system with better performance since the ring and the sleeve are both connected to ground. However, the best option for balanced systems is to use the balanced outputs (see below).

8.1.2 Balanced XLR Outputs

These XLR outputs (A.29, A.30) provide a balanced line signal that mirrors the one routed to the TRS outputs. However, due to the nature of the balanced systems,

their output will sound twice as louder as the pseudo-balanced one (+6 dB).

Even in this case, if the signal is too hot, it is possible to scale it down. Once the Line/Mic switch (A.31) is set to the lower position, the signal will be attenuated by 30 dB.

8.1.3 Mono Out

The bottom output (A.32) provides an additional, pseudo-balanced monophonic output with an attenuator.

It outputs the sum of the left and right channels. It can be used for live monitoring or for more creative uses, such as patching it to a specific amplifier for parallel processing in a studio environment.

An amplifying circuit provides an additional 6 dB of gain and 15 dB of attenuation calculated from the reference 0, the Line level of the pseudo-balanced stereo outputs. Rotate the mono-out fader (A.33) to the left to attenuate the signal and to the right to amplify it.

8.2 CREATIVE FUNCTIONS

The Masterone features a *Headphones* section designed for two purposes: 1) monitoring the mix through a pair of headphones with independent level, and 2) listening to individual channels without them being mixed through the Pre-Fader Listening controls.

8.2.1 Headphones

The headphones must be connected to the stereo jack output (A.26). Then, the rightmost potentiometer (A.27) sets the volume of the headphones, and the leftmost one (C.5) blends the main out signal (white) with the *PFL* signal (blue).

The headphones level is independent of the main fader's one.

8.2.2 PFL

PFL (*PreFader Listening*) allows the musician to send to the *Headphones* output any channel or group when their main fader is at 0, for instance, to preview it before being mixed.

PFL is achieved through two operations: pushing the *PFL* button (C.4) on the Channel or Group modules or on the *Aux* input (the blue LED will light up) and adjusting the *PFL* level through the *PFL Blend* knob (C.5).

PFL previews the channel's sound before the main fader: this means that its amplitude will be determined by the Red VCA level, which means that the green and yellow *Sends* cannot be *PFL'd* from the channel.

This is when the Group PFL comes in handy: to prelisten the effect sends and returns before sending them in the mix, you can mute the Group's and activate its PFL button: from now on, everything that the Group manages

¹⁰ See the *Core Concepts* chapter, section 12, p. 10.

will be safely prelistened without affecting the main mix, including individual Channels' Main Fader settings, sends and returns.

Please note that *Safe Solo* overrides *PFL*: this means that you can perform *Safe Solo* when a group is in *PFL*, but you cannot *PFL* a channel whose Solo in Place button is off when its group is in *Safe Solo* mode: the reason is that, as explained above, the *Safe Solo* works as a “*Mute* region,” i.e., muting all the unselected channel's red VCAs.

9 MASTER (DISCONTINUED)

The Master module is the last step in a CGM setup, and its primary purpose is to deliver the Eurorack system's audio to the outside world.

It consists of three sections: the amplitude control (white), the Headphones/PFL section (blue), and the Auxiliary input (purple).

9.1 AMPLITUDE CONTROL

The main control is the *Master Fader* ([A.22](#)), which sets the volume of the sound at the Master's left and right outputs ([A.20](#), [A.21](#)). This is the overall amplitude of the sum of the connected group: at this stage, it can gain an additional 6dB.

The Master features two columns of five LEDs each (three green, one yellow, and one red) that act as a visual monitor of the audio levels on the left and right channel, respectively. It acts a LED VU-meter, with the LED values being, from bottom to top: -6dBu, -1dBu, +4dBu, +7dBu, +10dBu.

9.2 AUXILIARY STEREO INPUT

The Master module's purple section features a stereo 3.5 mm jack input ([A.23](#)) with a dedicated amplitude control knob ([A.25](#)). Patching any audio source to this input will add it to the main mix.

The Auxiliary Input features a PFL button ([C.4](#)), just like the Channels and the Groups, which allows you to monitor the sound before blending it to the mix.

9.3 CREATIVE FUNCTIONS

The Master module features a *Headphones* section designed for two purposes: 1) monitoring the mix through a pair of headphones, with an independent level, and 2) listening to individual channels without them being mixed through the Pre-Fader Listening controls.

Read more about these functions on section [8.2](#) above.

10 TECHNICAL DATA

10.1 FLOW CHARTS

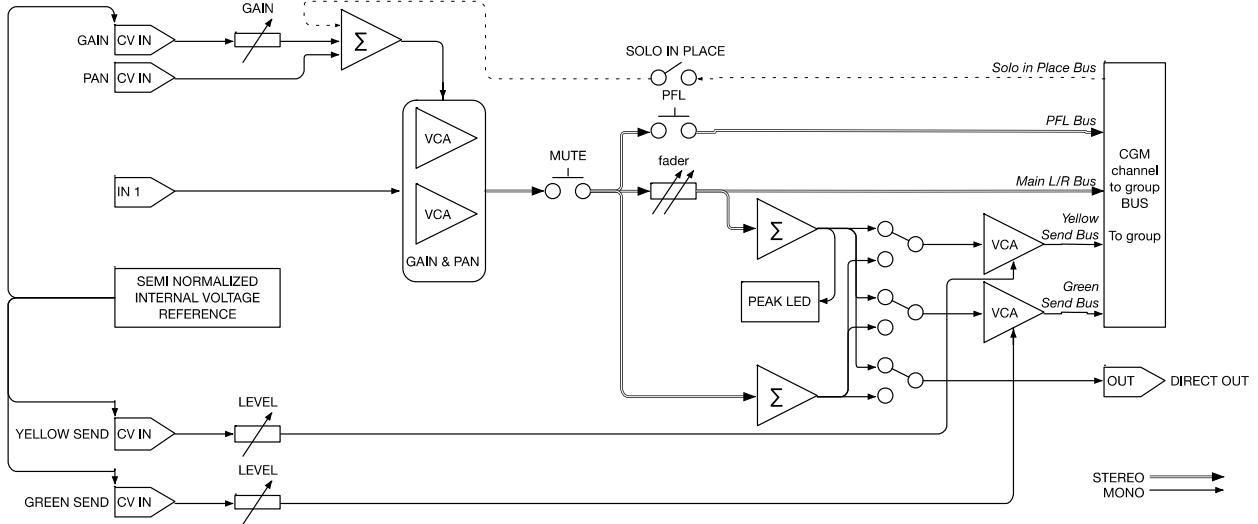

Figure 22: Channel flow chart.

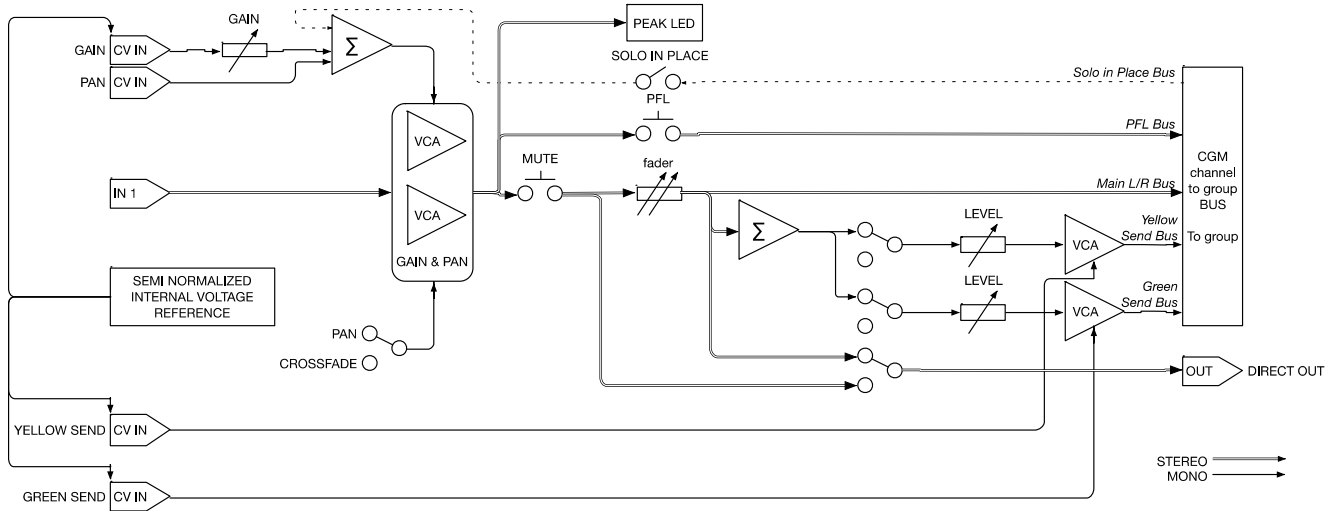

Figure 23: Stereo Channel flow chart.

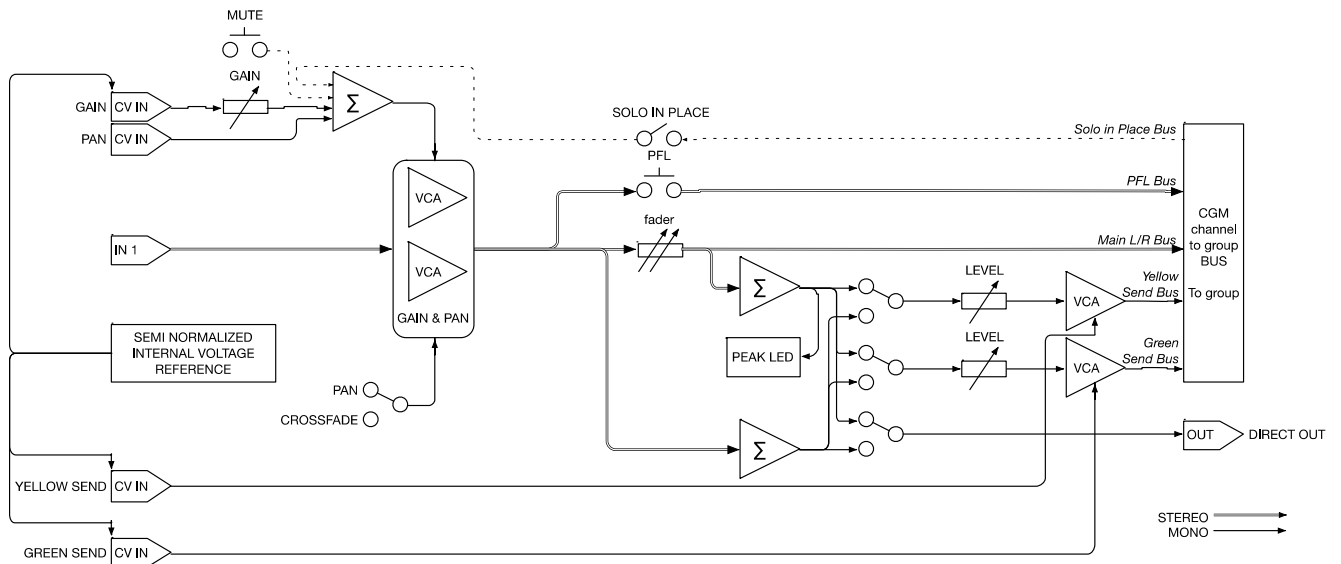

Figure 24: Quad Stereo Channel simplified flow chart (one of the four sections).

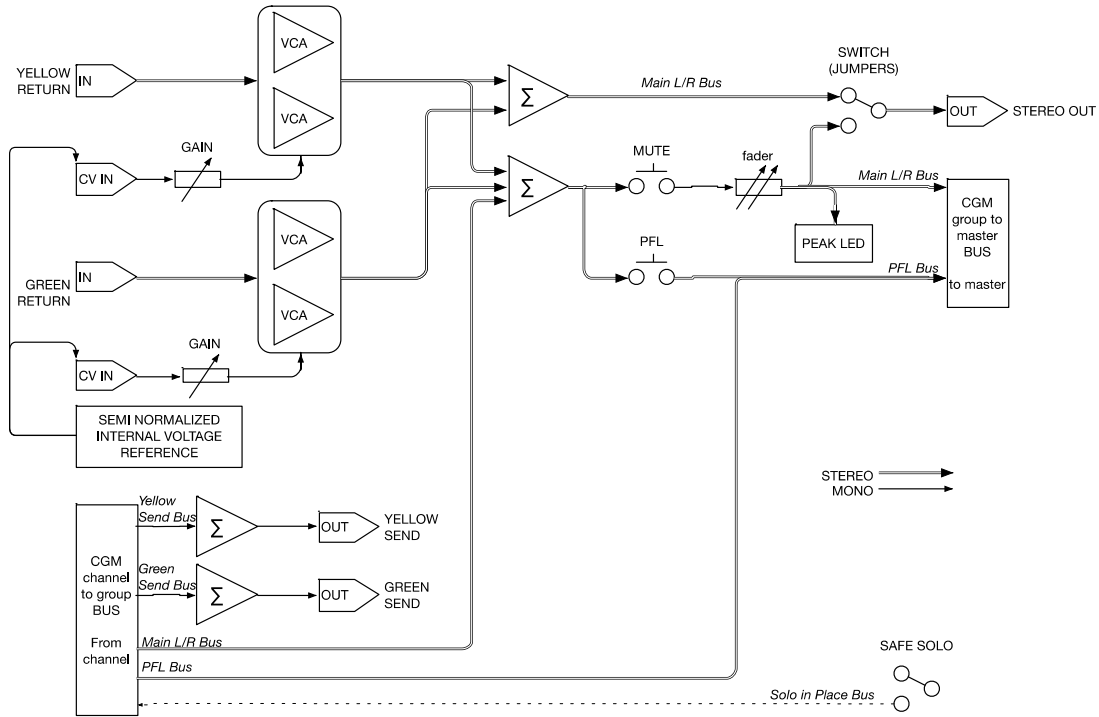

Figure 25: Group flow chart.

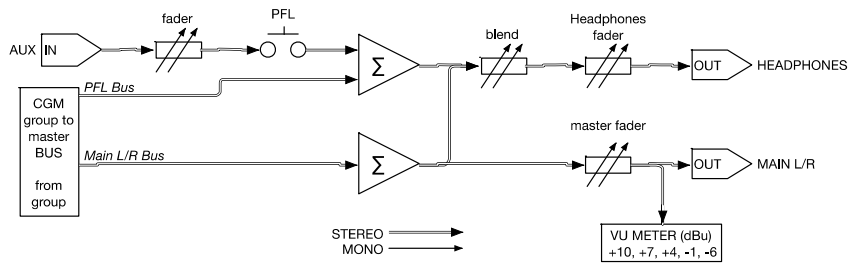

Figure 26: Master flow chart.

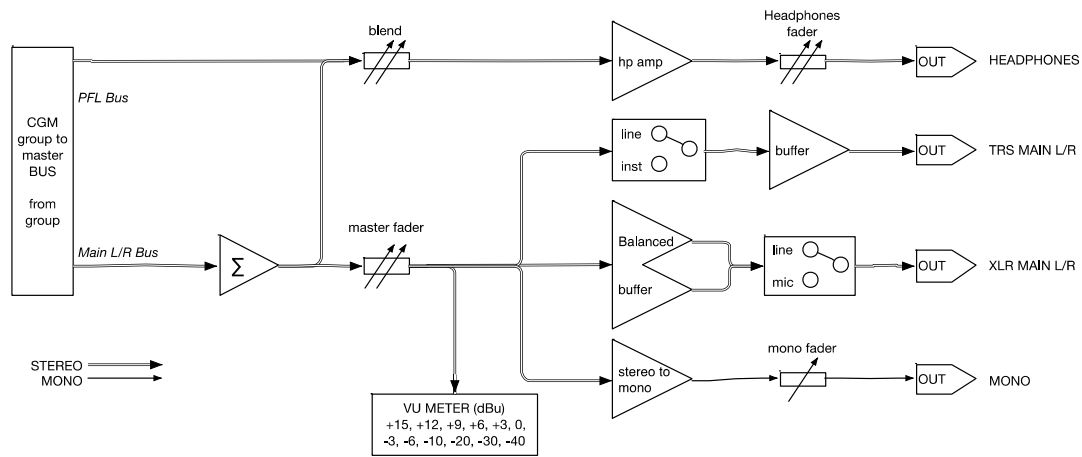

Figure 27: Masterone flow chart

10.2 SPECIFICATIONS

Parameter	Details	Min	Typ	Max	Unit
Size	C		6		HP
	SC		6		
	QSC		18		
	G (2016)		6		
	G		6		
	M		6		
	M ^{ONE}		12		
Depth	I		6		mm
	All modules		38		
Current Draw (I)	C	+12 V	80		mA
		-12 V	80		
	SC	+12 V	70		
		-12 V	45		
	QSC	+12 V	170		
		-12 V	170		
	G (2016)	+12 V	80		
		-12 V	75		
	G	+12 V	60		
		-12 V	60		
	M	+12 V	62		
		-12 V	44		
	M ^{ONE}	+12 V	80		
-12 V		80			
+12 V		110			
-12 V		105			
I	+12	35			
	-12	35			
Recommended warmup time	All modules		30		min
			>25		
Audio Input Impedance	C	Mono	>10		K Ω
		Stereo	>20		
	QSC	Mono	>10		
		Stereo	>20		
		Aux	10		
	G (2016)	Mono	>20		
		Stereo	>40		
	G	Mono	>10		
		Stereo	>20		
	M (2)		>3		
	I		>30		

Audio Output Impedance	C direct output		≥35	Ω	
	SC direct output		≥100		
	QSC local output		≥100		
	G (2016)		≥100		
	G		≥35		
	M ^{ONE}	¼" TRS	Unbalanced		≥35
			Pseudo-balanced		≥70
		XLR	Line level		≥220
Mic level	≥440				
I			≥100		
CV input range	VCA	Usable voltages	0	10	V
		Absolute knob offset	7		
	Send	Usable voltages	0	10	
		Absolute knob offset	7,5		
	Pan	Usable voltages	-10	10	
		Absolute knob offset	10		
Return	Usable voltages	0	10		
	Absolute knob offset	7,5			
CV Input Impedance	C		>90	KΩ	
	SC				
	QSC				
	G (2016)				
	G				
	M				
Maximum output level before clipping	All the CGM modules' outputs		≥17	dBu	
Gain scale	C (4)	Direct output	11		dB
		Send to G (2016)	18		
		Send to G	18		
	SC (4)	Direct output	10		
		Send to G (2016)	12		
		Send to G	12		
	QSC (4)	Local output	8		
		Local send output	8		
		Send to G (2016)	8		
		Send to G	8		
	G (2016) (4) (5)	Output referred to C and SC	6		
		Output referred to QSC	0		
		Return to G (2016) output	12		
	G (4)	Output referred to C and SC	6		
		Output referred to QSC	0		
Return to G output		12			
M/M ^{ONE}	Output referred to G output (4)	5			
	Headphones referred to G output (4)	7			
M aux input (7)			27		
Frequency response (8)			0.01	40	KHz
Harmonic Distortion (9)			<0.3		%
Panpot Center Position Tolerance	C		<2		dB
	SC		<2		
	QSC		<1.5		
Max VCA attenuation	C		≤70		dB
	SC		≤70		
	QSC		≤70		

- (1) Max data obtained with heavy driven output onto low impedance load.
- (2) Stereo signal on a single stereo jack.
- (3) ≥3% THD.
- (4) Without any CV applied and all pot at maximum. Measures subject to ±2 dB tolerance.
- (5) Jumpers allowing output of sum of channels and return.
- (6) Masterone measured from a single unbalanced ¼ " output.
- (7) Referred to master outputs. Measures subject to ±2 dB tolerance.
- (8) Within 1 dB, measured at +10 dBu at master output onto a 1 KΩ load.
- (9) THD+N. On a complete system (Channel to group to master) measured at 1 KHz with output signal of +10 dBu onto 1 KΩ load with a 10 Hz to 80 KHz bandwidth measurement system.

SAPÈL

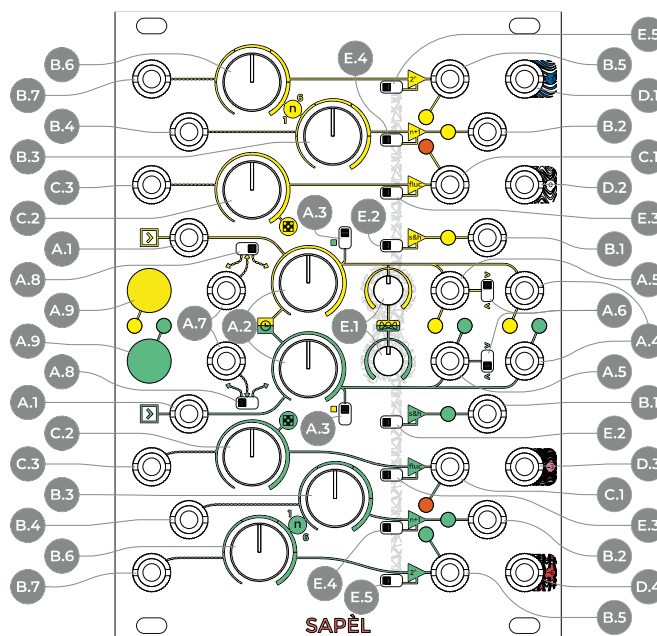

Figure 28: SAPÈL interface.

A Clocks

- A.1 Clock Input
- A.2 Clock Rate
- A.3 Single/Both Switch
- A.4 Main Clock Output
- A.5 Random Clock Output
- A.6 Random Clock Mode
- A.7 Gate/CV Modulation Input
- A.8 Gate/CV Modulation Switch
- A.9 Sample-and-Hold (S&H) Button

B Stepped Random Voltages

- B.1 S&H Output
- B.2 $n+1$ Output

B.3 $n+1$ Value

- B.4 $n+1$ Value CV Input
- B.5 2^n Output
- B.6 2^n Value
- B.7 2^n Value CV Input

C Fluctuating Random Voltages (FRV)

- C.1 FRV Output
- C.2 FRV Rate and Global Rate of Change
- C.3 FRV Rate and Global Rate of Change CV Input

D Noise Outputs

D.1 Blue Noise Output

- D.2 White Noise Output
- D.3 Pink Noise Output
- D.4 Red Noise Output

E Probability Distribution

- E.1 Probability Distribution
- E.2 S&H Probability Distribution Switch
- E.3 Fluctuating Probability Distribution Switch
- E.4 $n+1$ Probability Distribution Switch
- E.5 2^n Probability Distribution Switch

1 PHILOSOPHY AND DESIGN

SAPÈL is an analog generator of random control voltages for Eurorack modular systems. It generates a wide variety of random values to add dynamics to your patches. Such values are sampled on analog thermal noise, to guarantee the truest random generation.

Its main section is composed of two identical clusters of four Sample and Hold circuits each (yellow and green), which continuously generate as many different random values.

Three of the four S&H circuits in each cluster provide stepped random voltages: two are quantized (in “notes”) and one is unquantized; the last S&H circuit features an integrator to generate a fluctuating stream of random voltages.

The three stepped voltage generators are synced, which means that they will output three different values at the same time. The yellow and green generators have two

independent internal clocks, which can be replaced with an external one, or temporarily overridden either via external gate or manual button. A copy of the trigger used to sample the stepped random values is available, as well as a random trigger output.

The fluctuating voltage generator, on the other hand, is independent and has its own potentiometer to define its rate.

Each of the two S&H clusters samples its values from analog noise, thus providing a “true” and completely unpredictable randomness.

The second section of SAPÈL features four analog noise outputs, which are derived from the analog noise used to sample random values.

2 NOISE OUTPUTS

This section features four analog noise outputs, which are, from top to bottom:

- [D.1 Blue Noise](#) (+3dB/oct spectrum);
- [D.2 White Noise](#) (0dB/oct spectrum);
- [D.3 Pink Noise](#) (-3dB/oct spectrum);
- [D.4 Red Noise](#), also known as brown or Brownian (-6dB/oct spectrum).

Each noise “color” has its own distinct tone, which can be used for sound-designing purposes.

Theoretically, White Noise has an equal distribution of intensity across all the frequencies per bandwidth. Practically, in the analog domain, White Noise is a sound which has a flat spectrum in the audible range, or, in simpler terms, which can “hit” all the frequencies with equal amplitude at the same time. It is perceived as a highly inharmonic sound but, to the peculiar nature of the human ear, it appears slightly unbalanced towards higher frequencies.

For this purpose, SAPÈL also features a Pink Noise output. Pink Noise is basically a White Noise filtered through a -3dB/Oct filter, which “smoothens” its higher frequencies in order to deliver a more “balanced” sound for the human ear. Pink Noise features an equal distribution of intensity per octave, instead of bandwidth.

Red Noise is similarly generated, but the filter has a slope of -6dB per octave. The result is a low, “rumbling” tone.

Finally, Blue Noise is a kind of inharmonic sound whose intensity increases proportionally to the frequencies. In other words, the higher part of the spectrum will appear to be louder, and the overall result is a high-pitched hissing sound which lacks bass frequencies.

Practice the *Noise Outputs* with these Techniques:



[Percussion Sounds #1](#)
[Percussion Sounds #2](#)
[Percussion Sounds #3](#)
[Accents #2](#)
[Noise Oscillator #1](#)
[Noise Oscillator #2](#)

3 VOLTAGE SAMPLING

The yellow and green generators, as said above, work independently the one from the other. Each of them samples three random values at the same time from a different noise source. The three voltages are thus uncorrelated: one is unquantized (i.e. with no fixed “pitch”), one is quantized in semitones, and one quantized in octaves.

The sampling process happens when a trigger or gate activates the S&H circuit, which “picks” the value played

by the noise source at a given time, and “holds” it until another trigger or gate is generated. There are four ways to activate the S&H circuit for each of the two generators: internal clock, external clock, manual S&H button, external S&H gate, plus an “extra” mode which combines the clocks (let it be internal or external) of both the green and yellow generators.

By default, each generator is driven by an internal clock. The clock section generates a regular clock signal (called *Main Clock*) and two *Random Clocks* (on which see below). Both the yellow and the green random sources have their own independent clock. The regular train of impulses provided by the *Main Clock* is used to sample the random values and is also routed to the *Main Clock* output ([A.4](#)). The *Random Clock* does not affect the S&H circuit, but it is available for advanced modulation purposes through the *Random Clock* output ([A.5](#)).

3.1 INTERNAL CLOCK AND CLOCK MODULATION

The built-in clock frequency is managed by the *Clock Rate* knob in the center of the module ([A.1](#)). Rotate the knob counterclockwise to decrease the sampling rate and clockwise to increase it.

It is possible to modulate the frequency of the clock via the Gate/CV Modulation Input ([A.7](#)).

This input can have two separate functions, selectable via the dedicated switch ([A.8](#)): it can route the incoming CV to modulate the clock frequency, or it can use any voltage higher than 3V to trigger the S&H cluster (see below, [§3.5](#)).

When such a switch is set to the right, the incoming CV will modulate the clock frequency: a positive CV will increase the clock speed, and a negative one will decrease it.

3.2 EXTERNAL CLOCK

It is possible to use any external trigger to activate the S&H by patching it to the External Clock Input ([A.1](#)).

Whenever a cable is patched to this input, the internal clock is bypassed (i.e., it will no longer trigger the S&H circuit). This input accepts triggers and gates only: this means that in order to sample a value, it needs an incoming signal with a really steep rising edge, such as square waves, pulse waves or sawtooth waves with negative ramp (beside of course trigger and gate impulses). Other kind of impulses such as sine or triangle waves will be ignored.

3.3 CLOCK MIX

It has been said that the green and yellow sections of SAPÈL have their own independent clock generation. It is possible, however, to blend them in a more creative way through the *Single/Both* switch ([A.3](#)), which feeds the other generator’s clock into the one currently in use. To

activate the clock mix, set the switch to the position marked by a square of the other generator's color.

This feature works with both internal or external clocks, and it affects the sampling section only: all the clock outputs will maintain their regular behavior.

3.4 MANUAL SAMPLING

No matter if you are using the built-in clock or an external one, that stream can be temporarily bypassed with the manual S&H Button (A.9).

By pushing the S&H button the stream of impulses is overridden by a gate high signal, which samples a value and holds it until it is released. A dedicated LED will light up as long as the button is pushed. The main clock output, however, will still output a trigger signal.



Practice some uses of the buttons with this Technique: [Hold](#)

3.5 EXTERNAL GATE SAMPLING

This last operation can be automated using the *Gate/CV Input* (A.7).

When the switch (A.8) is set to the leftmost position, any CV signal higher than 3V can be patched in the *Gate/CV Input* and used to override the internal clock.

With this configuration it is possible to use other signal than gates and triggers to drive the S&H cluster, such as sine or triangle waves or even the internal fluctuating random, however a gate or a square signal generally provide best results.

3.6 CLOCK OUTPUTS (MAIN AND RANDOM)

Every time the S&H Cluster samples a value, a 2ms trigger is outputted from the *Main Clock output* (A.4). If a steady pulse is used, such as the internal clock or an external one, this output will provide an exact copy of the clock.

On the left of the *Main Clock output* lies the *Random Clock output* (A.5), which can either add or subtract triggers from the one in use through its switch (A.6), located between the two clock outputs.

When the switch is up, or in additive mode, it outputs all the clock impulses generated from the clock with the addition of other random clocks; when the switch is down, or in subtractive mode, it randomly subtracts triggers from the ones generated to trigger the S&H Cluster, i.e., it outputs only some of the triggers that are outputted by the *Main Clock out*.

In both modes, the random clock density depends on the *Global Rate of Change* (See below, §4.3).



Practice the clocks with these Techniques:

[Random Clocks #1](#)

[Random Clocks #2](#)

[Ratcheting-Like Effect #3](#)

[Clock Bursts #1](#)

[Clock Bursts #2](#)

[Double-Clock Trick](#)

[Random-Clock Sequencing](#)

Since SAPÈL's clock is 2 milliseconds long, it works really well if patched to FUMANA's *Modulation Input*:

[Percussion Sounds #2](#)

4 RANDOM VOLTAGES

SAPÈL is designed to provide a vast array of random voltages with different articulations at the same time. Each of the two S&H clusters (yellow and green) can be divided into two units: the first one generates three random voltages simultaneously, and it is activated by the clocks or gates described above; the second one generates continuous, fluctuating random values and it is completely independent from the clocks and gates.

Remember that SAPÈL samples random values from thermal noise: it is recommended to warm it up adequately to make it reach the operation range.

4.1 NON-QUANTIZED RANDOM VOLTAGES

The most basic stepped random values generator is the Sample and Hold circuit, which outputs its values through the *S&H* output (B.1)

This generator is designed with an independent random generator and creates non-quantized stepped voltages with a range varying from 0 to 7.5 V. Non-quantized means that if the values are used, for example, to modify the pitch of an oscillator, the result will be a series of sounds whose frequency may not sit within the conventional 12-semitone Western chromatic scale. It can be used for more experimental music compositions or, more traditionally, to modulate other non-melodic parameters such as timbre, filter frequency, amplitude...



Practice the S&H circuit with this Technique: [Ratcheting S&H](#)

4.2 QUANTIZED RANDOM VOLTAGES

The other two stepped random voltage generators output voltages which are quantized (i.e., "forced") to the 1V/octave standard. If applied to an oscillator's frequency, the result will be a series of random "notes"

The design of these two generators follows the historical Buchla module Source of Uncertainty Model 266, but with a substantial different approach. The circuit has been designed from scratch in order to obtain a more “random” voltages distribution and an extremely precise voltages quantization, capable of generating precise semitones or octaves.

At first glance, the main difference with the *S&H* circuit mentioned above is that the quantized random voltage generator features a knob which controls the n parameter and whose range goes from 1 to 6, as in the original 266 module. The role of the n parameter varies according to each generator’s label: 2^n and $n+1$.

The 2^n Output (B.5) is quantized in 1/12 V steps, or semitones in the 1V/oct scale. In this case, the *Value* knob sets the exponent of 2 which, in turn, determines the number of different values that may be generated by the circuit. Given that n can be any number from 1 to 6, there are 6 possible ranges of values that this circuit can generate:

n Knob value	Number of generated voltages
2^1	2
2^2	4
2^3	8
2^4	16
2^5	32
2^6	64

Table 4: n values for 2^n quantized random voltages.

Please note that as n gets higher, a larger range of voltages (or “notes”) are generated, starting from 1 (0 V) up to 64 (5.25V). This will guarantee the musician more control over the final output and will lead to more expressive results: for example, a low n value will always generate smaller intervals and low pitches, while a high one may provide larger leaps from one semitone to the other, as well as higher notes. Please refer to the graph below (Figure 29) for a graphic representation of the exponential note distribution across all the n settings:

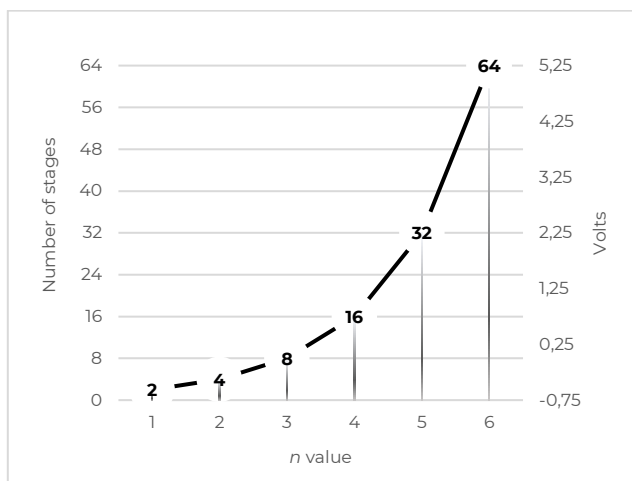

Figure 29: 2^n quantization chart.

Please note that the graph shows an ideal behavior: the actual number of voltages may differ due to the mechanic potentiometer tolerance, even at its extreme positions.

The $n+1$ output (B.2) is quantized in 1V steps, or octaves in the 1V/oct scale. In this case, the *Value* knob (B.3) sets the number which will be summed to 1, which, in turn, determines the number of different octaves that may be generated by the circuit. Again, given that n can be any number from 1 to 6, there are 6 possible ranges of octaves that this circuit can generate:

n Knob value	Number of voltages generated
1+1	2
2+1	3
3+1	4
4+1	5
5+1	6
6+1	7

Table 5: n values for $n+1$ quantized random voltages.

Even in this case, that higher is the number, the larger becomes the range of voltages (or “octaves”) that are generated, starting from 1 (0 V) up to 7 (6 V). Please refer to the graph below (Figure 30) which displays the linear increment of the octaves across the different n settings.

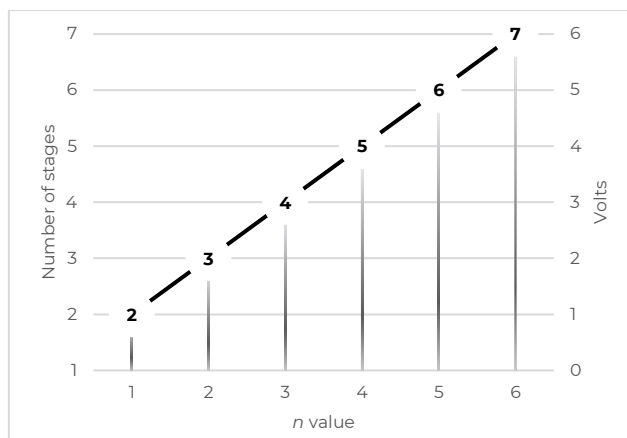

Figure 30: $n+1$ quantization chart.

Both the $2n$ and the $n+1$ can be controlled via external CV (B.4, B.7) thus allowing the musician to automatically vary the range of values to be outputted.



Practice the use of the $n+1$ output with these Techniques:
[Ratcheting-Like Effect #2](#)
[Voice Spread #1](#)
[Random Delay](#)

4.3 FLUCTUATING RANDOM OUTPUT AND GLOBAL RATE OF CHANGE (RANDOM CLOCK DENSITY CONTROL)

The main purpose of this section is to output (C.1) a continuous, fluctuating random voltage which ranges 0

to 7.5 V and whose rate of change (or “frequency”) is controlled by its potentiometer (C.2).

This random generator is the only one (in both the S&H clusters) which is not affected by the main clocks or gates; however, on the other hand, it can affect the clock generation itself.

The second purpose of this section, is in fact, to control the *rate of change* of the random clocks: by rotating the C.2 knob clockwise, both the fluctuating voltage frequency and the random clock density (let it be in *more than* or *less than* mode) are increased, and vice versa.

Just like for the quantized voltage generators, this parameter can be modulated with any CV using its CV input (C.3). The external modulation will affect both the fluctuation rate and the random clock density.



Practice the *Global Rate of Change* with this Technique:
[Fluctuating Random & Global Rate of Change](#)

5 PROBABILITY DISTRIBUTION (STORED RANDOM VOLTAGES)

The four S&H generators can be controlled as for magnitude of the voltages that are more likely to be generated: this parameter is called probability distribution, it is globally set by the *Probability Distribution* knob (E.1) and it can be activated independently per each of the four S&H circuits through the four Probability Distribution Switches (E.2, E.3, E.4, E.5).

The knob sets the magnitude of voltages which will be generated more frequently: by default, it is set to the middle position, which means that medium voltages will be outputted more often than high or low ones. Rotate it to the left to raise the probability of generating lower voltages, and to the right for higher ones.

Please note that this setting will not block the SH& circuits to generate different voltages than the ones whose probability is set to be higher: they will just be generated less frequently.

This is a significant difference, for example, from the n Knobs function of the quantized random voltages: in that case, the value defines the “pool” of values that may be picked; here, on the contrary, the Probability Distribution Knob sets the magnitude of voltages that are more likely to be generated within the “pool” selected above.

6 TECHNICAL DATA

6.1 REVISIONS

Starting from lot no. 220101 we rearranged the board layout to ease the assembly, shorten the supply chain, reduce the needed components, and reduce the manufacturing waste. The functions of the modules and its tech specs have not been changed.

6.2 FLOW CHART

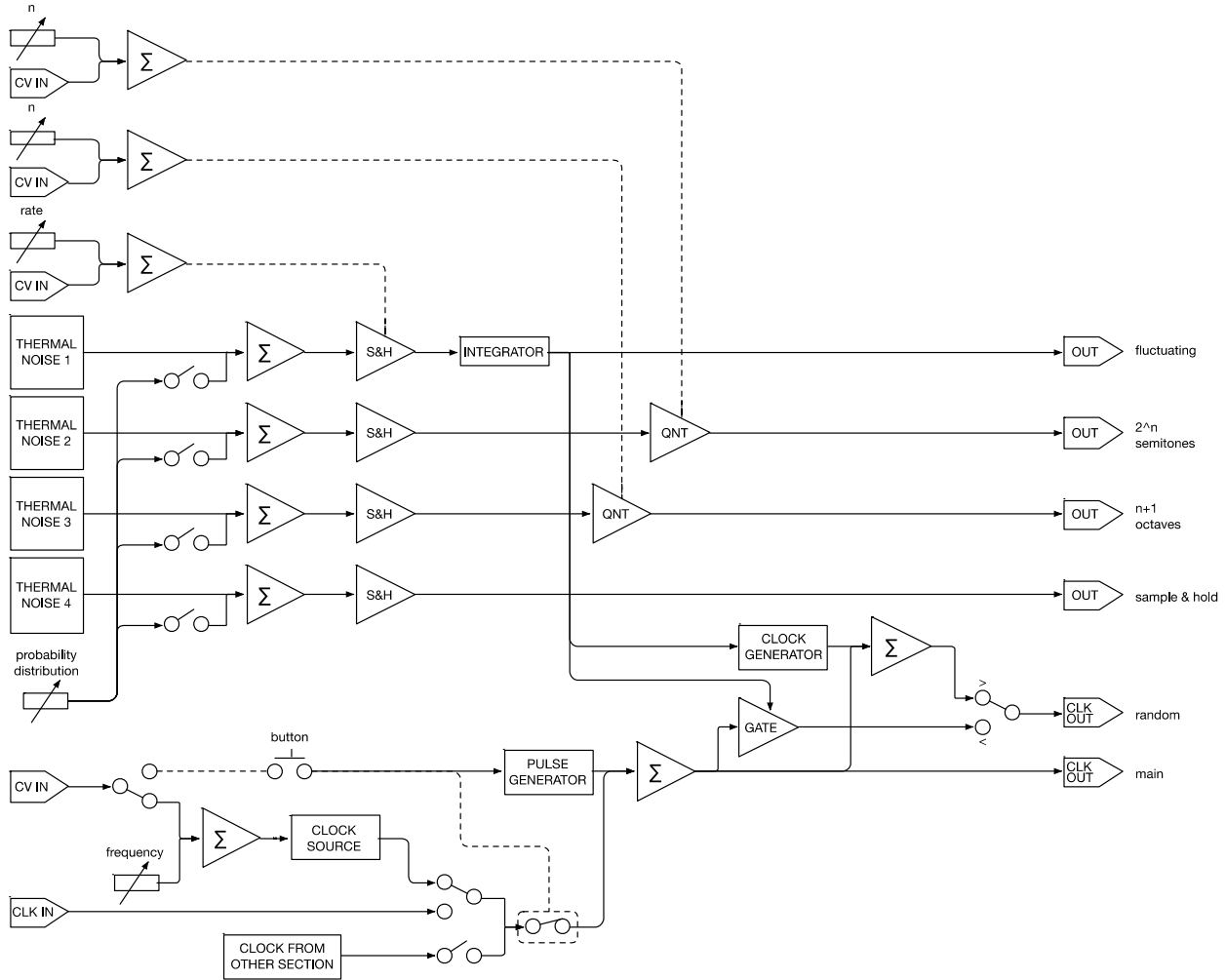

Figure 31: SAPÈL's flow chart.

6.3 SPECIFICATIONS

Parameter	Details	Min	Typ	Max	Unit
Size			18		HP
Depth			38		mm
Current Draw	+12 V			250	mA
	-12 V			170	
Recommended warmup time			30		min
CV input impedance			>90		K Ω
Clock input impedance	on positive pulses		>90		K Ω
	clamping negative pulses		~30		
Built-in clock frequency (10)		~0.1		60	Hz
Quantized Random Voltage Tolerance			<1		%
	global offset	-10		10	mV
Clock output	period		~2		ms
	amplitude		~9		V
Sampling Glitch	on sample & hold			<400	μ s
	quantized outputs			n.a.	
Colored Noise Output	blue		10		dBU RMS
	white		10		
	pink		7		
	red		4		
	global tolerance	-2		2	dB
CV input range	2 ⁿ	Usable voltages	-10	10	V
		Absolute knob offset	7,5		
	n+1	Usable voltages	-10	10	
		Absolute knob offset	7,5		
	Fluctuating random voltages speed	Usable voltages	-10	10	
		Absolute knob offset	15		
Clock modulation	Usable voltages	-10	10		
	Absolute knob offset	15			

(10) Lower frequencies may be achieved (longer times) with a negative CV used as modulation.

FUMANA

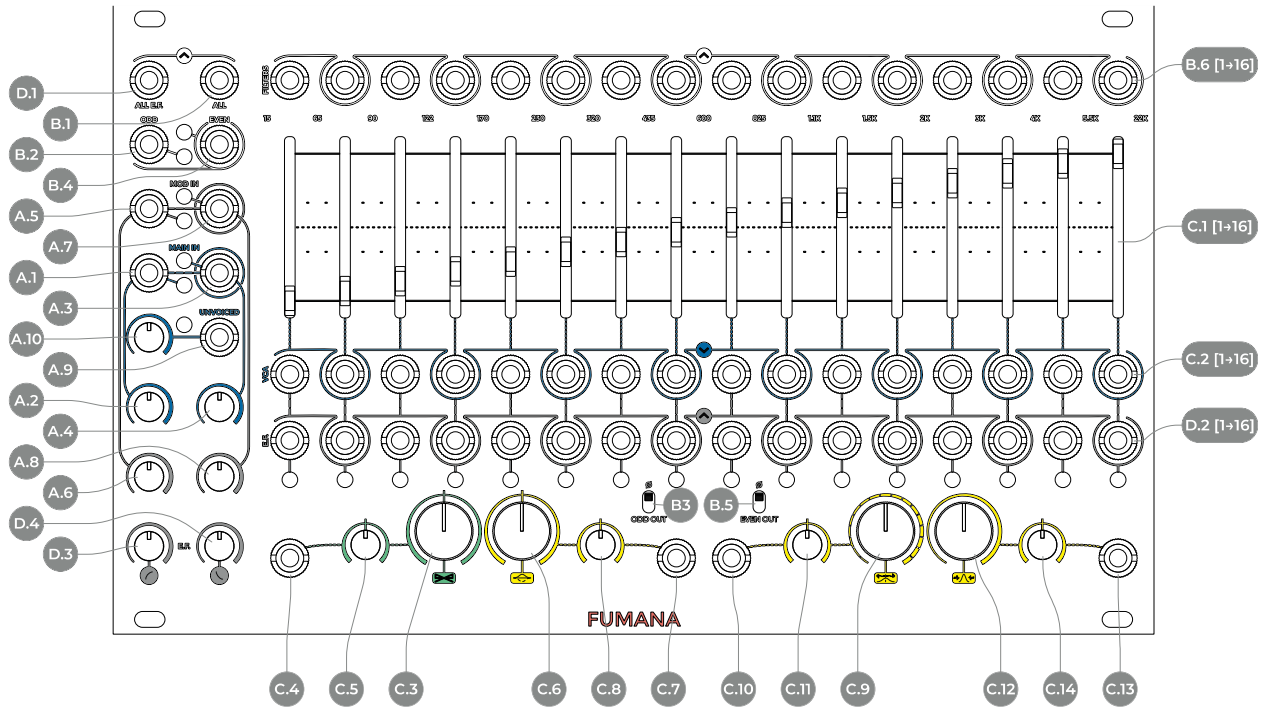

Figure 32: FUMANA interface.

A Audio Inputs

- A.1 Main Odd Input
- A.2 Main Odd Level
- A.3 Main Even Input
- A.4 Main Even Level
- A.5 Mod Odd Input
- A.6 Mod Odd Level
- A.7 Mod Even Input
- A.8 Mod Even Level
- A.9 Unvoiced Input
- A.10 Unvoiced Level

B Audio Outputs

- B.1 All Output

- B.2 Odd Output

- B.3 Odd Output Phase

- B.4 Even Output

- B.5 Even Output Phase

- B.6 Individual Band Outputs

C Controls and CV Inputs

- C.1 VCA Faders

- C.2 VCA CV Inputs

- C.3 Tilt Control

- C.4 Tilt CV Input

- C.5 Tilt CV Input Attenuverter

- C.6 Peak/Notch Control

- C.7 Peak/Notch CV Input

- C.8 Peak/Notch CV Input Attenuverter

- C.9 Center Control

- C.10 Center CV Input

- C.11 Center CV Input Attenuverter

- C.12 Width Control

- C.13 Width CV Input

- C.14 Width CV Input Attenuverter

D Controls and CV Outputs

- D.1 All Envelope Followers Output

- D.2 Individual Envelope Followers Outputs

- D.3 Envelope Followers Rise Control

- D.4 Envelope Followers Fall Control

1 PHILOSOPHY AND DESIGN

FUMANA is a dual all-analog fixed filter bank. Each filter bank is composed of an array of 16 independent bandpass filters tuned to specific frequencies.

FUMANA is designed around one basic core principle: modify the spectral content of the incoming audio signal by filtering it through 16 bandpass filters in parallel and then vary the amplitude of each resulting band.

Even though this core principle is relatively simple, the key feature of FUMANA is that it provides a wide set of controls over the bands' amplitude. Each band feeds a VCA, and the spectral content of the incoming sound can thus be modified:

- by the faders, which are individually CV-controllable;
- by the envelope followers which are generated by the analysis of the sound patched in the Modulation input;
- by the global parametric controls such as Tilt and Scan.

Furthermore, a flexible input/output signal routing allows the musician to “split” the 16 filters into two 8-band spectral processors by grouping the odd and even bands separately. It will be possible to process two independent signals, or to blend two signals into one output, or even to perform two different sonic treatments over the same signal and route it to two different output sections.

Individual outputs are available for each band, both for the Main sound (i.e., the filtered one) and for the Mod sound (i.e., the resulting envelopes).

Since a spectral transfer tool may be used as a “vocoder-like effect”, the FUMANA provides an input for an external noise which may be used for fricative/sibilant sounds.

1.1 SPECTRAL TRANSFER: A BRIEF HISTORY

In the modular synth domain, the most famous device for performing spectral transfer was the legendary Model 296, designed by Donald Buchla in the seventies. It was a 16-band filter bank, which featured one input for the odd bands and one for the even bands: this solution allowed the artist to process two different signals at the same time, but it also allowed to transfer the harmonic content of one to the other via dedicated switches. It was thus possible to analyze the odd bands and transfer their amplitude to the even bands, and vice versa.

This design was clever because it took advantage of a single array of 16 filters, but the resulting spectral transfer was somehow “approximated” because the modulation signal came from the analysis of the adjacent band, i.e., another frequency area of the spectrum, albeit quite close.

The FUMANA pushes this concept even further, but still within the analog domain. An additional bank of 16 filters is added, specifically for analysis purposes, with a different band-pass slope (see below §5).

When performing a spectral transfer, it is fundamental to consider the harmonic content in both main and modulation audio signals.

Poor harmonic content on the *Main* signal: if a pure sine (one harmonic) or any signals with poor harmonic content is used, there are not many chances to hear good results exciting several bands. Supposing it is a sine wave with a frequency of 105 Hz (which lies then on band 3), theoretically something happens only when band 3 is excited from the modulation signal.

Rich harmonic content on *Main* signal: this means more chances to have several bands excited by the envelope followers control voltages created by the modulator filterbank.

Poor harmonic content on *Modulator* signal: allows creation of very selective envelope followers signals, which translates in a very selective spectral transfer. If the modulation signal changes pitch or has a very variable content, it will for sure result in a more heterogeneous spectral transfer.

Rich harmonic content on *Modulator* signal: allows a very rich spectral transfer. Just keep in mind that if you are using a square wave in the modulation with frequencies varying from 100 to 200 Hz, probably you won't hear

that much difference, due to the richness of harmonics of the square wave.

Since this operation works on the individual bands' amplitude, the general setting for spectral transferring requires the faders all the way down, so that when the modulator signal is silent, the main signal is silent as well.

It is also possible, however, to combine the amplitude increments of spectral transferring with the faders, leaving the main signal a little or completely open and using the main one to add some accents to some or all the bands.

1.2 PANEL OVERVIEW

A consistent color and graphic coding make the front panel easy to understand at a glance, once properly understood.

The main graphic solution is the distinction between the odd and even bands: since the two groups can work independently, every input or output related to the even bands is marked by a circle around the jack socket. (The bands are numbered 1-16 from left to right: odd bands are band 1, 3, 5, 7, 9, 11, 13, 15; even bands are 2, 4, 6, 8, 10, 12, 14, 16).

Another key coding is the distinction between the *Main* filter array and the *Mod* filter array. Everything that relates to the *Main* filter bank, which is the circuit directly affecting the sound that is heard, is marked by the color blue, let it be audio output, CV input or even the faders' LED color.

On the other hand, everything that relates to the *Mod* filter bank, which is the one that extracts the envelopes from the modulating signal and modifies the harmonic content of the main filter bank, is marked in grey, including the individual envelope output LEDs (which flash white when active).

Finally, the green and yellow colors mark the Global Spectral Editing tools: the former relates to the Tilt control, the latter to the Scan controls.

2 AUDIO INPUTS

FUMANA has two pairs of inputs, which are called *Main In* (blue), and *Mod In* (gray), short for “modulation input”, plus a fifth input called *Unvoiced*. ([A.1](#), [A.3](#), [A.5](#), [A.7](#), [A.9](#)).

Each pair consists of inputs for the *Odd* and *Even* bands, which are semi-normalled together. This means that when only one patch cable is connected to one of the two inputs, it automatically feeds the other. If you want to use different sources for odd and even bands, simply use two different cables. If, however, you want to feed only the odd bands and not the even (or vice versa), simply plug a dummy cable to the undesired input.

Each of the four inputs has a dedicated amplitude potentiometer (A.2, A.4, A.6, A.8): it is thus possible to different levels for the odd or even filters within each pair of inputs. This also means that if you want to emphasize the even bands on the main signal, you can simply add more gain to them, and less to the odd ones.

The fifth input, named *Unvoiced*, is designed for adding some depth to the fricative consonants that might be missed when performing vocoding-like operations. It features its gain control as well (A.10). However, we suggest not to limit yourself to this very specific use: its design allows for other creative uses (see below, §4.4)

The red LEDs connected to the odd and even inputs light up displaying the amplitude of the incoming audio after the gain level.

3 AUDIO OUTPUTS

FUMANA's main audio outputs are the three in the top left area: *All* (B.1) outputs all the bands, while *Odd* (B.2) and *Even* (B.4) output respectively only the odd and only the even bands.

In addition to these, FUMANA features 16 direct outputs (B.6) on top of each band. The main difference between these and the other three outputs is that, while the *All*, *Odd* and *Even*, are sums of groups of bands after their respective VCAs, these 16 *band outputs* are pre-VCA outputs, directly from the bandpass filters.

These are useful, for example, to parallel process only a single band or a group of selected bands. In that case the 333 can be very helpful, since it is capable of perfectly summing up to 7 signals into a single jack.

The use of the individual filter outputs does not affect their respective band's presence in the *Odd/Even/All* outputs: these stages are completely independent.

The *Odd* and *Even* outputs also feature a phase inversion switch (B.5): this switch may be useful in case you want to merge one of those signals with the *All* output, and dynamically emphasize (phase summing) or dynamically attenuate (inverted phase summing) only the *Odd* or *Even* bands.



Practice the various outputs with these *Techniques*:
[Fumana Feedback #1](#)
[Reverb Feedback](#)
[Odd/Even Crossfade](#)
[Individual Outs #1](#)

The result of the sum of *Odd* and *Even* outputs is slightly different from the *All* output, because the *All* output uses an additional low pass filter at 18 KHz in order to obtain a less "sharp" upper end. This circumstance can happen when using harmonically dense signals, or heavy

modulations (see more in the Transfer Functions section, §7.1). In case you need a crispier sound, consider using the *Odd+Even* combination.

4 AUDIO PROCESSING AND MODULATION PATH

FUMANA's filter bank processes the sound patched to the *Main* input by varying each band's amplitude through a VCA circuit. Such variation can be achieved in four different ways, many of which can easily co-exist:

- through the individual band faders;
- through the individual band CV inputs, right below the faders;
- through the Macro Spectral Editing tools (Tilt and Scan)
- through the spectral transferring function performed by any sound patched to the *Mod* input.

The result of all these modulations is outputted by the *All*, *Odd* and *Even* outputs, and it is visually displayed by the 16 blue LEDs placed on the 16 band faders, whose intensity graphically displays the amplitude of the respective band after any modulation applied. The relationship of the modulations is displayed in Figure 33, and it will be further explained in the next paragraphs.

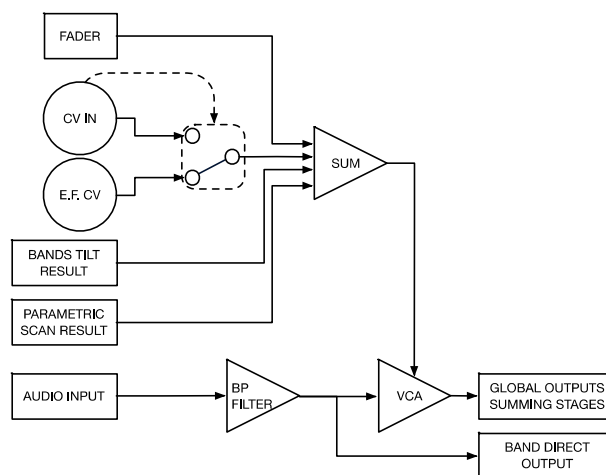

Figure 33: FUMANA's modulation routing.

4.1 FADERS AND CV

The main CV comes from the 16 faders (C.1), one per band. In the lowest position, the VCA is closed: raise the fader to increase the selected band's amplitude. This operation can be automated through the 16 individual jack sockets below each fader (C.2), which provide inputs for external CVs. The CV inputs accept any signal either bipolar or unipolar, even at audio rate, up to ~1000 Hz

(after which a lowpass filter is applied, see Figure 34): it is thus possible to perform AM over an individual band!

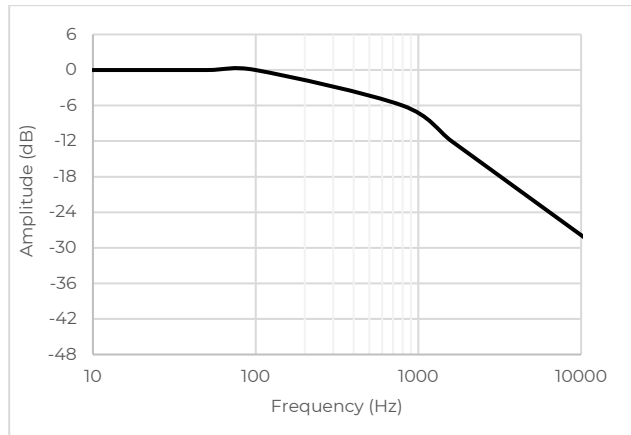

Figure 34: CV frequency roll-off.



Practice the individual bands' CV inputs with this *Technique*: [Spectral Sequencing](#)

4.2 MACRO SPECTRAL EDITING

The yellow and green areas at the bottom of the module are, respectively, the bands' parametric scanning and tilting. These two functions are independent from one another, and we designed them to quickly modulate multiple bands with a few controls. Each of these parameters has a main potentiometer ([C.3](#), [C.6](#), [C.9](#), [C.12](#)) and its CV input ([C.4](#), [C.7](#), [C.10](#), [C.13](#)) with a dedicated attenuverter ([C.5](#), [C.8](#), [C.11](#), [C.14](#)).

4.2.1 Tilt

The green section is the *Tilt* parameter ([C.3](#), [C.4](#), [C.5](#)). Assuming a fixed fulcrum in the middle of the 16 bands (between band 8 and 9), the Tilt allows to gradually emphasize half of the bands and simultaneously attenuate the other half. The more a band is far from the fulcrum the more it will be emphasized or attenuated: it is thus possible to change the balance between lower or higher frequencies.

When the knob is set to its center, no band is affected. Move it counterclockwise to emphasize bands 1-8, with an emphasis that gradually decreases from the first to the eighth. At the same time, bands from 9 to 16 are progressively attenuated from the center towards the edge. Rotate the knob clockwise to emphasize bands 9-16 and attenuate bands 1-8.

Please note that, due to the pot's tolerance, the "off" position lies around noon, but it may slightly vary from unit to unit.

One of the possible uses of the band tilt is to temporarily attenuate the lower frequencies' presence when the mix is particularly "crowded" in that frequency range.

Feed the CV input with the same envelope of your bassline or kick drum and regulate the attenuverter to dynamically attenuate FUMANA's low end and emphasize its higher register at the same time. It is a sort of spectral sidechain!

4.2.2 Parametric Scanning

The yellow section is called *Parametric Scanning* due to its similarity to a three-variable parametric equalizer. In any parametric EQ, it is possible to set the center frequency, the gain value, positive or negative (often called peak/notch), and the slope. Fumana's parametric scanner is similar, but it works as a voltage controlling the amplitude of multiple bands, rather than a single filter with variable slope.

The first control is called *Peak/Notch* ([C.6](#), [C.7](#), [C.8](#)) and it selects the amount of emphasis or attenuation of the scan: when the knob is around the middle, there is no emphasis; rotate it clockwise to add a positive gain and counterclockwise to add a negative gain, which can be useful to perform notch-filter-like operations.

The *Center* control ([C.9](#), [C.10](#), [C.11](#)) sets where, among the bands, this emphasis/attenuation has its maximum/minimum level: when fully counterclockwise, no band is emphasized; by rotating it clockwise, the central position shifts from band 1 to band 16; when fully clockwise, no band is emphasized as well.

With the *Width* parameter ([C.12](#), [C.13](#), [C.14](#)) it is possible to emphasize the bands to the left and right of the central position set by the Center control: you can set a width from 0 to all the 16 bands (16 bands are audible only if the *Center* knob is set to noon).

Please note that, due to the pot's tolerance, the "off" position of the Peak/Notch lies around noon, but it may slightly vary from unit to unit: it may thus be normal to experience some emphasis of reduction when the knob is at noon.

If you want to bypass the parametric scanner, use the Width control and rotate it completely counterclockwise.



Practice the different parametric scanning controls with these *Techniques*: [Percussion Sounds #1](#), [Percussion Sounds #3](#), [Raw CV](#)

4.3 SPECTRAL TRANSFERRING: MODULATION FILTERS AND ENVELOPE FOLLOWERS

The modulation circuit performs spectral transfer from one signal (the modulator) to another (the carrier).

The modulating signal must be patched to the *Mod* input, which feeds an array of 16 band-pass filters similar

in design to the ones in the main array; then, each filter feeds a dedicated envelope follower; the resulting 16 envelopes create as many different control voltages that are semi-normalled to the VCA input jacks of the main filter bank (C.2). By doing so, the energy of each band of the modulating signal will open or close the corresponding band of the carrier signal, thus “transferring” (hence the name) the modulator’s harmonic footprint to the carrier.

As said above in the paragraph about the Modulation Routing, patching a jack into any individual band CV in will break the semi-normalled connection of the envelope followers.

A common modulator signal, as we said earlier, is the human voice, which changes its spectral content with every phoneme, and thus excites different bands over time, but we encourage experimenting with any other sound source.

The duration of the resulting envelopes can be modified with the *E.F. Attack* and *Release* control knobs (D.3, D.4). The leftmost position offers the fastest envelope response; rotating it clockwise will result in slower envelopes.

Usually, the only parameter in the time domain used to modify the envelope followers’ signals is the Release time. FUMANA is equipped with the Attack time as well, in order to have more control over the harmonic content modification and obtain more subtle results.

The circuit response is non-linear, meaning that the knobs allow for more precise control over the fast times rather than the long ones, which is useful when processing a signal with fast transients. Given that the more conventional use of this circuit is to perform vocoding-like operations, it is also more frequent that fastest envelopes are required.

Each envelope has an independent time-scaling factor, longer for lower frequencies and faster for the higher frequencies, in order not to cut any audio wave semi-period.

The envelopes resulting from this spectral analysis are also available on the 16 *E.F. outputs* (D.2), which can be used as CV for otherpoints of the patch without affecting their transfer to the VCAs of the main filters.

An *All E.F.* output is also provided, which sums all the envelopes together (D.1).



Practice the All EF out with this *Technique*:
[Sidechain #2](#)

The amplitude of the Envelope followers also depends on the level of the modulation source: the FUMANA is designed to work with input potentiometers in center position (12 o’clock) when modular levels are used (bipolar 10 Vpp). Potentiometers can be used to amplify weak signals or attenuate hot ones.



Practice some peculiar spectral transferring patches with these *Techniques*:

[Kick Drum #2](#)

[Percussion Sounds #2](#)

[FUMANA Feedback #3](#)

[TZFM Spectral Transferring](#)

[Spectral LFO](#)

4.4 THE ‘UNVOICED’ SECTION

Unvoiced sounds (fricative/sibilants) are common in human languages and can be found in words containing or starting with s, f, z, ch and other fricative sounds ([s] [z] [ʃ] [tʃ] [dʒ] [ts] [ʂ] [f] [v] [ϕ] [θ] [ʒ] etc.).

Historically, all vocoders have an additional section to manage these kinds of sounds, because they have a major impact in the speech clarity and also tend to disappear during spectral transferring.

Usually that section worked with a sort of “unvoiced detection circuit:” you can get an approximated idea of it imagining a “de-esser”, which detects the presence of certain frequencies in the sound spectrum, and instead of doing a selective band compression attenuating that frequencies, it controls a sort of mixer that changes the input of the filter from the main to a noise signal, and is capable of very fast transients.

FUMANA has been designed to be a spectral editing tool, more than a vocoder: for this reason, since its sketches shared a lot of things with vocoding circuits, we developed our own approach of the *Unvoiced* section, which can also lead to different results.

It manages the amplitude of the patched signal, filters it roughly between 3000 and 5500 Hz, and sums the result to the main signal whenever the modulator hits bands 14 and 15. The main difference between our circuit and other implementations is thus that it preserves the main sound, instead of switching to the unvoiced only.

The jack socket in the *Unvoiced* area is the audio input (A.9): a good sound for the unvoiced management is white or pink noise, such as SAPÈL’s ones, but we recommend experimenting with other sounds, like a copy of the very modulator, or other unorthodox sources. The potentiometer (A.10) sets the signal level.

It is also important to specify that even if the input is one (mono), the detector and the amplitude manager of that noise is dual: bands 14 and 15 have independent envelope followers and VCAs. This means that when used with two different modulation signals and two outputs (odd and even), the result of the unvoiced signal added to the main one is totally independent between the two outputs.



Practice the Unvoiced input with this *Technique*:
[Unvoiced Input](#)

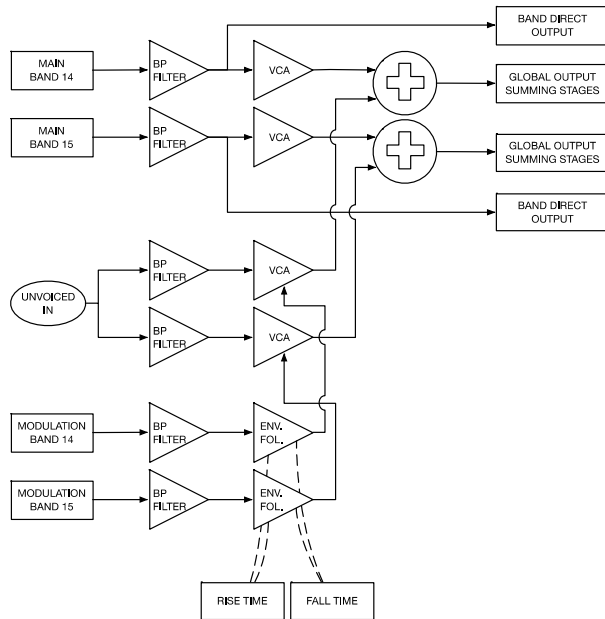

Figure 35: FUMANA's *Unvoiced* section.

The envelope generators for the unvoiced input have a peculiar design: in the FUMANA, they tend to be much “softer” than normal to reduce risks of “envelopes bounces” resulting in abrupt and unpleasant “noise sparks”.

This approach allows to use the unvoiced section also for non-vocal purposes. A good example is using drums with cymbals/hats as modulation source: in this case, the unvoiced section helps to detect when there is material and recreate cymbals or snare wires. Anyway, this does not limit you to put any kind of waveform in the unvoiced input and start to experiment by yourself.

5 FILTER DESIGN

Each of the two filter arrays is based on 16 parallel analog bandpass filters. The main filter bands from 2 to 15 are mainly based on Bessel calculation, while bands 1 and 16 are respectively a lowpass and highpass filter with a custom method to obtain better musical results. All bands on the main filter array use an 8th order slope (48 dB/oct).

Conversely, the modulation filter array uses a 6th order filter slope (36 dB/oct), and an additional stage to compensate each band's energy. The calculation method used was optimized for this specific purpose.

The crossover frequency between each filter from band 2 to 15 approximates an interval of ~ 5.5 semitones (or $11/24$ of an octave). This results in a distance between odd bands (and also between each even band) of ~ 11 semitones ($11/12$ of an octave), or a Major 7th. The ratio is defined to limit the chance of a recursive tone emphasis/attenuation over the whole audio spectrum.

The first and last band's frequencies are calculated to achieve the best regulation of “sub-bass” and “upper-end”.

We designed the filters to guarantee the flattest frequency response on the ALL output, which within ± 1.5 dB from band 2 to 15, and globally between ± 4.5 dB. This achievement translates into an extremely transparent filter.

Each band has an individual trimmer to set its band amplitude in case a different result is needed. The trimming procedure is NOT present in this manual since it MUST be performed by Frap Tools' authorized personnel only. Frap Tools may not be held responsible in any way for problems or damage to persons or property or to the device itself if any trimming or disassembly is tried or performed without authorization.

6 PATCH EXAMPLES

The following examples assume the same starting point. The first time you use the FUMANA and you're not 100% familiar with it, we suggest keeping these settings:

- set the 4 volumes of the *Odd* and *Even* bands of both the *Main* and *Modulation* section to the middle (at 12 o'clock);
- keep the envelope followers' *rise* and *fall* times at minimum (counterclockwise);
- put all volume faders to the minimum.

6.1 16-BAND SPECTRAL TRANSFER

The easiest thing to perform a 16 bands spectral transfer is patching a square wave to any of the main input (blue) and a triangle or sine wave to the modulation input (grey). Patch only one cable to the inputs and leave the other unpatched: this automatically feeds the other input thanks to internal semi-normalled connections. Now patch only one output (ALL output) to the input of your mixer to hear what happens.

At this point, if the modulation signal is within the audio range and has a “modular” amplitude level (bipolar 10 Vpp), you will notice that at least one of the white LEDs lights up. This means that an envelope follower CV has been created in the modulation filter array and has been transferred to the main filter section VCA of that band. Change the modulation signal's frequency to see the white LEDs flashing up and down the spectrum.

6.2 DUAL 8-BAND SPECTRAL TRANSFER

You need four signals to do a proper dual 8-band spectral transfer: two carriers and two modulators. For this example, you can proceed with a square and a pink noise into the main inputs (blue). The modulation inputs (grey) may use, only for example purposes, a simple triangle wave on the odd bands and a percussive signal on the even bands. Now patch two outputs (Odd and Even) to two different inputs of your mixer to hear what happens.

If the modulation signals are within the audio range and have a “modular” amplitude level (bipolar 10 Vpp), you’ll notice that, when varying the frequency of the triangle wave onto the odd bands, the odd LED will start to light up, and you will hear the result of this spectral transfer via the odd output, while the even bands LEDs will light up based on the amplitude and the harmonic content of the percussive signal.

6.3 HYBRID SPECTRAL TRANSFER

You can even do a sort of hybrid spectral transfer using, for example, two different signals for the main input and one as modulator. In this case, if the modulator waveforms both from the same oscillator, and you pick up the output from the All output, you’ll obtain a behavior that

merges two different waves, in-phase. Otherwise, using different sound sources and picking up the signals from the Odd and Even outputs, you’ll obtain two different signals, which can be processed independently, but which share a similar harmonic emphasis.

Of course, you can do the opposite, using two modulators on the same single source applied onto the main filter array.

6.4 VOCODER-LIKE BEHAVIOR

The easiest way to perform a 16 bands kind of vocoder is very similar to the 16 bands spectral transfer: you can patch a square wave, or any signal with rich harmonic content (which may also vary in pitch and timbre), or a noise (i.e., a non-pitched sound) to any of the main input (blue). Then, apply a voice to the modulation input (grey). This automatically translates in a vocoding effect. The use of the unvoiced section may also be of interest. Remember that the vocal signal should be at “modular” level, 10 Vpp

Having two main signals and two separates voices translates the FUMANA in a coarser dual 8-band vocoder: of course, the results cannot be at the level of the 16 bands, since it is using only half of them.

7 TECHNICAL DATA

7.1 TRANSFER FUNCTION

All tests performed after 30 minutes of warmup at room temperature of 23°C using pink noise at a sampling rate of 96 KHz. The resolution used is 65*536 points which corresponds to ~0.732421875Hz of windowing.

Please note that the transfer function of the module may vary from module to module, $\pm 2\text{dB}$ is still accepted. The causes are the components tolerance and the trimming which is done manually per each band to define their amplitude. The trimming is done to achieve the flattest band on the all output. Results on odd or even are then a consequence of this setting.

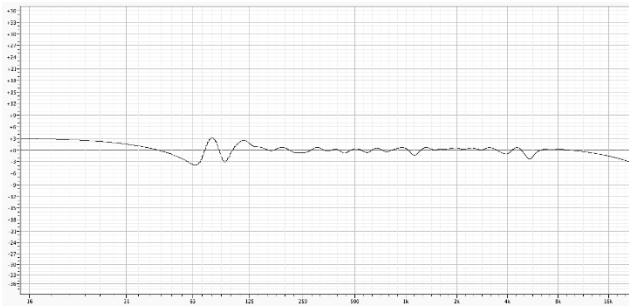

Figure 36: All bands output, complete.

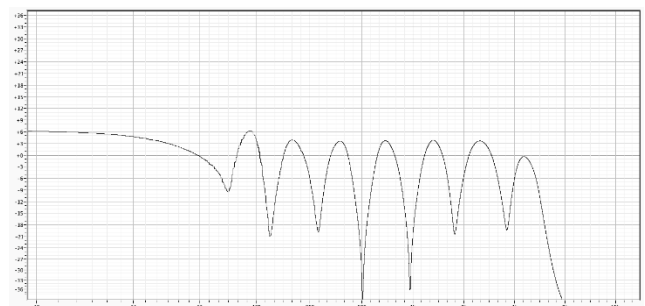

Figure 37: Odd bands output, complete.

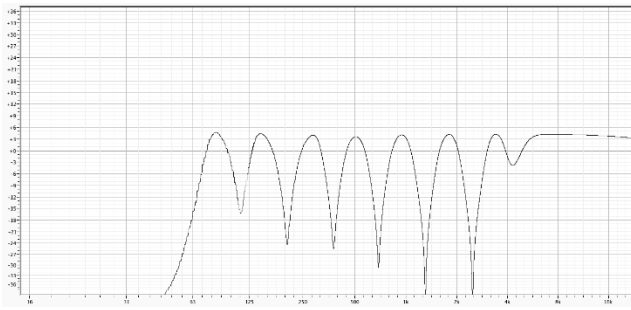

Figure 38: Even bands output, complete.

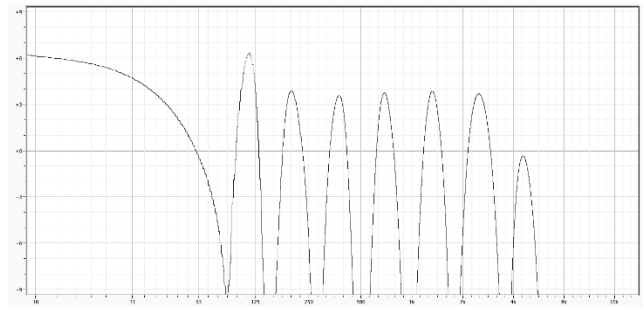

Figure 40: Odd bands output, detail.

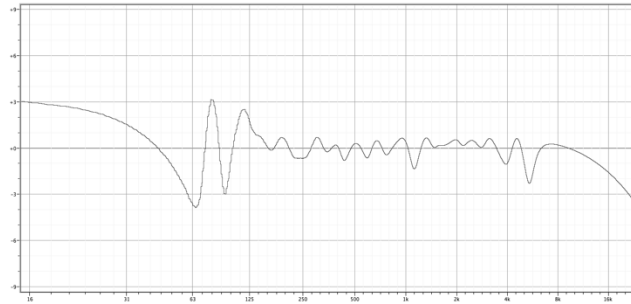

Figure 39: All bands output, detail.

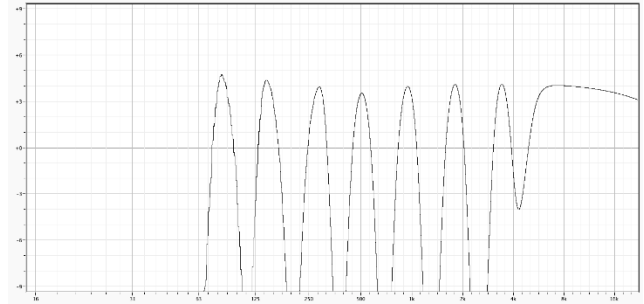

Figure 41: Even bands output, detail.

7.2 SPECIFICATIONS

Parameter	Details	Min	Typ	Max	Unit
Size			42		HP
Depth			38		mm
Current Draw				430	mA
				390	
Recommended warmup time			30		min
CV input impedance			>90		K Ω
CV output impedance			<50		Ω
Audio Input impedance			>20		K Ω
Audio Output impedance			<50		Ω
	Individual Filters		<250		
Envelope followers' amplitude from 0/10 V. (1)			± 5		%
CV input range	Tilt	Usable voltages	-10	10	V
		Absolute knob offset	10		
	Gain	Usable voltages	-10	10	
		Absolute knob offset	12		
	Position	Usable voltages	-10	10	
		Absolute knob offset	12		
	Width	Usable voltages	-10	10	
		Absolute knob offset	9		
Individual band VCA	Usable voltages	-10	10		
	Absolute knob offset	5			

(1) To avoid incorrect behavior when driving external VCAs, a slight negative BIAS voltage is applied to each envelope circuitry to prevent a minimum positive voltage on output due to components' tolerances.

FALISTRİ

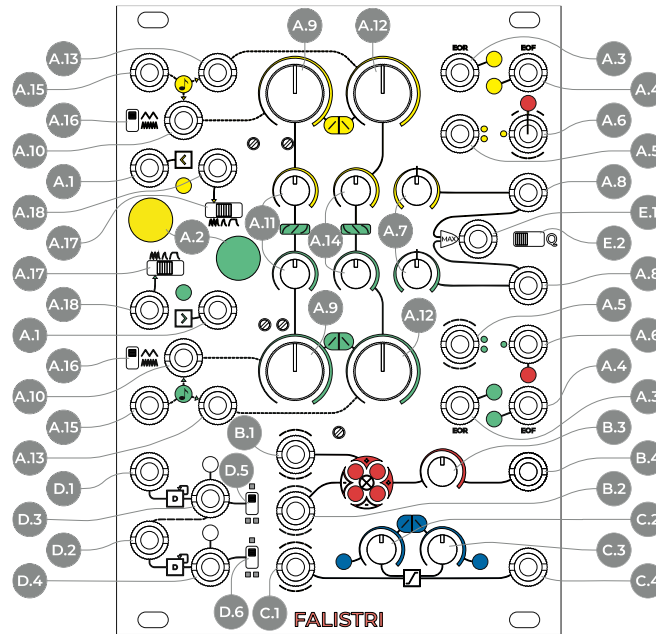

Figure 42: FALISTRİ interface.

A Generators

- A.1 Trigger/Gate input
- A.2 Trigger/Gate Button
- A.3 End Of Rise
- A.4 End Of Fall
- A.5 Bipolar Output
- A.6 Unipolar Output
- A.7 Attenuverter
- A.8 Attenuverted Output
- A.9 Rise Time
- A.10 Rise CV Input
- A.11 Rise Shape
- A.12 Fall Time
- A.13 Fall CV Input

A.14 Fall Shape

- A.15 V/oct Input
- A.16 Time Scale
- A.17 Play Mode
- A.18 Force Loop Input

B Four-Quadrant Multiplier

- B.1 Four-Quadrant Multiplier Input 1
- B.2 Four-Quadrant Multiplier Input 2
- B.3 Four-Quadrant Multiplier Level
- B.4 Four-Quadrant Multiplier Output

C Linear Slew Limiter

- C.1 Linear Slew Limiter Input
- C.2 Linear Slew Limiter Rise Control
- C.3 Linear Slew Limiter Fall Control

C.4 Linear Slew Limiter Output

D Dual Cascaded Frequency Divider (DCFD)

- D.1 DCFD Input 1
- D.2 DCFD Input 2
- D.3 DCFD Output 1
- D.4 DCFD Output 2
- D.5 DCFD Range 1
- D.6 DCFD Range 2

E Quadrature Section

- E.1 Max Output
- E.2 Quadrature

1 PHILOSOPHY AND DESIGN

FALISTRİ is an analog control voltage generator and processor: we call it our “movement manager” because it adds motion to any patch through envelopes, LFOs, and many other voltage transitions.

The module consists of two main parts: the upper two-thirds of the panel contains two identical function generators, while the lower third contains a dual cascaded frequency divider, a linear slew limiter, and a four-quadrant multiplier.

2 FUNCTION GENERATORS

The generators provide a “function”, i.e., a continuous transition from a low voltage to a high one and back with a definable duration. If the function is momentary,

meaning that it needs a timing pulse to start, we often call it an envelope. If the function retriggers itself right when it reaches the lowest point, it becomes an LFO. If the LFO is faster than 20 Hz, it becomes an audio oscillator. The main difference between a function generator and a “simple” oscillator or LFO is that it can have more stages than just a plain oscillation up and down, and it gives control over each stage’s time, rather than a unique frequency control that changes the whole waveform period.

We call “stage” any portion of our voltage function with a precise duration, shape, and trajectory. Conventionally, only the “active” parts of an envelope are called stages: an envelope that ramps up, stays high, and then ramps down has three stages, an ADSR has four, and so on. However, the portion where the function stays at 0 is a

stage too, which we will need when we'll talk about quadrature mode.

Falistri's functions have thus four stages: one where the voltage ramps up, one where it stays high, one where it ramps down, and one where it stays low.

The high and low "static" stages can be so fast that they become undiscernible, thus making the voltage go up and down and back with no pauses, like an oscillator.

The two "dynamic" stages, where the voltage ramps up or down, have controls over their times and shapes, making it possible to precisely define the voltage trajectory:

- The times are independent of the shapes – when sculpting an envelope, you can freely morph from logarithmic to linear to exponential slope, without changing the time needed to complete Rise or Fall (and their Loop time when used as an oscillator);
- The shapes are exclusive per stage – you can have logarithmic Rise and logarithmic Fall, Linear Rise and Logarithmic Fall, or any other combination of the modes. Of course, any blending in between these shapes is achievable, allowing deep sculptures of sound when used as control voltage as well as an audio source.
- To have finer control over the envelope times, a switch changes between a "fast" and a "slow" generator time scale.

Since a function develops over time, it must start with a timing pulse, which can be an external gate, a manual button pressing, or the end of the envelope itself, which creates a looping envelope.

2.1 ANALOG OUTPUTS (ENVELOPE, LFO, OSCILLATOR)

Each generator provides 5 different outputs: two gates and three CV.

The Control Voltage outputs are:

- Bipolar ([A.5](#), marked with two dots): range ± 5 V, useful for bipolar LFO or when the function is used as an audio rate oscillator.
- Unipolar ([A.6](#), marked with one dot): range 0/+10 V, useful for any traditional envelope modulation.
- Attenuverted ([A.8](#), connected to the A.7 attenuverter): ranges from 0 V to anything up to +10 V or 0 V to any down to -10 V. It is still unipolar, but with assignable polarity and amplitude.



Practice the attenuverters with these Techniques:
[Complex Envelopes #2](#)
[Kick Drum #1](#)

2.2 TRIGGERS AND MODES

The switch on the right ([A.17](#)) defines FALISTRIS' "play modes", which are, from left to right:

- *Loop*: the function automatically retriggers when it reaches the end of its cycle (use this for an LFO or an audio oscillator);
- *Transient*: creates a one-shot rise-fall function, or AD envelope;
- *Hold*: when the signal used to trigger the function stays high (more than 1.5 V) for a longer time than the Rise stage, the function holds the highest value as long as the input gate does not come low again, thus being an AHR envelope. The time of "hold" is the difference between the gate time and the rise time. After that, when the gate goes low, the fall stage is recalled.

When the switch is in *Transient* or *Hold* mode, patching a positive voltage into the jack socket will force the play mode to *Loop*. This input also accepts audio-rate signals, for more experimental effects.

If a gate-high signal is patched to the jack connected to the switch ([A.18](#)) it forces the play mode to loop, ignoring the physical position of the button.



Practice the Force Loop with these Techniques:
[Ratcheting-Like Effect #1](#)
[Force Loop #1](#)
[Force Loop #2](#)

The *Trigger/Gate Input* and the *Trigger/Gate Button* trigger the envelope: you can use either the manual button or an external trigger or gate (for details concerning trigger and gate thresholds see the technical specification section below, 4.1).



Practice some uses of the buttons with this Technique:
[Hold](#)

If the function is running, any retrigger signal recalls the function's rise stage, this means that:

- if the function is already in its *rise* stage, nothing changes;
- if the function is in its *hold* stage, nothing changes;
- if the function is in its *fall* stage, it goes back to rise, starting from the *level* on which it left the fall stage;
- if the function is in its *rest* stage, it starts a new function.



Create a sort of flip sync oscillator through FALISTRi's retrigger behaviors:
[Falistri Sync](#)

To see how the different envelope shapes affect the retrigger behavior, continue reading until section 2.4.

2.2.1 Green Alternative Retrigger (On Rest)

The green function generator offers a unique feature that can be activated with a switch on the back of the module. It is up to the user to decide how it should behave:

- *To Rise* (lower position): same behavior as the yellow one;
- *On Rest* (higher position): the retrigger is effective only when the generator is at its rest stage.

This last feature allows you to use the generator as a formant oscillator, maintaining roughly the spectral content of the function you designed across several notes, and resulting in frequency divisions ($/2$, $/3$, $/4$, $/n\dots$) of the external frequency used to trigger it, when this “secondary” period is longer than the “master” one.

Since this switch is on the back of the module, it is meant to provide a set-and-forget option. However, in case of more than one FALISTRi on the same system, one might actually forget the setting: for this purpose, when the green generator is set *On Rest* and its play mode is *Transient* (see above, §2.2), the trigger/gate LED will not light up.

To check whether the green generator is set *On Rest* or *To Rise*, set the generator to *Transient Mode* and push the *Trigger/Gate* button (A.2): if the LED lights up, it's *To Rise*; if it doesn't, it's *On Rest*.

Please note that the *Quadrature* mode forces the *To Rise* mode, so the switch is ignored (see below, §2.6.1).



Practice the two behaviors with these Techniques:
[On Rest/To Rise Formant/Sync](#)
Then, create more unconventional sounds through the *On Rest* behavior:
[Undertones](#)
[Formant Arpeggiator](#)

2.3 TIMES

The stage times are managed by the *Rise* and *Fall Time* knobs (A.9, A.12). The *Rise* knob lets you set how much time the function takes to reach the maximum level. The *Fall* knob lets you set how much time the function takes to decrease and “rest” after the rising stage (when in *Transient* mode) and/or after hold (when in *Hold*).

These parameters can be independently modulated via any control voltage using the jack sockets connected to them on the left (A.10, A.13). Any positive voltage increases the knob value, while a negative one decreases it.

It is also possible to modulate these parameters simultaneously through the *V/oct input* (A.15), which is connected to the rise cv in and fall cv in. This input works in the opposite way; positive signals decrease the time and negative ones increase it. This socket is marked with a note symbol to point out that it is the one you may want to use as *V/oct Input*.

Keep in mind that to obtain perfect behavior over various octaves, you may want to keep both the *Rise* and *Fall* stages at similar values to make them use the same portion of the V/oct converter.

It is possible to choose between two different *time scales* using the switch on the left (A.16): the upper position has longer times, and it is thus more suitable for envelopes and LFOs; the lower position, on the other hand, provides extremely short functions on the microsecond time scale, and when looping it can be used as an audio-rate oscillator. This is just a general reference, as any possible combination of fast/slow and transient/cyclical is at hand for your sonic palette.



Practice the *Rise* and *Fall* CV inputs with these Techniques:
[Accents #2](#)
[Ratcheting-Like Effect #2](#)
[Percussion Sounds #1](#)
[FALISTRi Clock Manipulation #1](#)
[FALISTRi Clock Manipulation #2](#)
[FALISTRi Fake Delay](#)

2.4 SHAPES

Each stage's *shape* can be independently selected. A small potentiometer, below each time pot, allows you to morph between three shapes, from logarithmic to linear to exponential (A.11, A.14). It is extremely important to specify that the change of shape is completely independent of the time factor: this means that you can freely play with different wave shapes without changing the duration of the envelope / LFO, or without affecting the pitch when using FALISTRi as an oscillator. In this last case, the two small pots will play the role of an actual waveshaper.



Practice waveshaping with this Technique:
[Waveshaping](#)

It is useful to know that if the retrigger happens during the *Fall* stage and you are using different wave shapes

than linear, some interesting discontinuity will occur. This behavior happens because FALISTR1 is a triangle core generator and the wave shaping stage lies after the core.

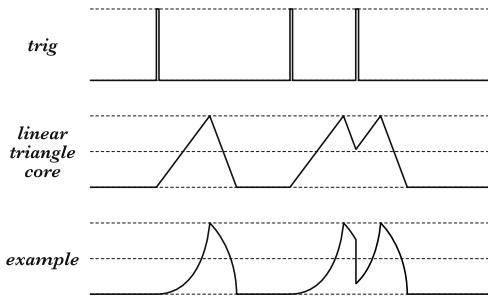

Figure 43: FALISTR1's retriggers with different envelope shapes.

2.5 DIGITAL OUTPUTS (GATES)

The Gate outputs are, from left to right, *End Of Rise* (EOR) and *End Of Fall* (EOF).

The EOR output provides a gate-high signal as soon as the rising stage ends. The EOF provides a gate-high signal when the falling stage ends.

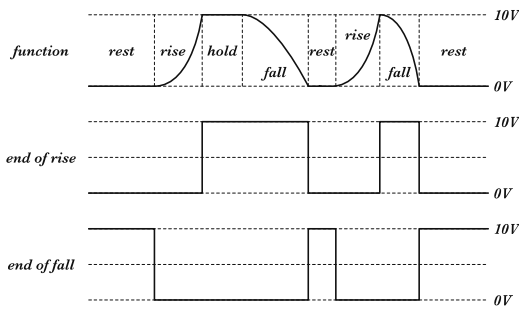

Figure 44: FALISTR1's envelope shapes, EOR, EOF.

The high/low times depend on the envelope setting and mode.

2.5.1 End of Rise (EOR)

If the generator is set to *Transient* or *Loop*, the EOR gate will stay high from the end of the rising stage to the end of the falling stage. In other words, its output will provide a high signal for the whole duration of the falling stage. If the falling stage is set to the minimum value, for a “ramp” envelope, the EOR will be as fast as a trigger signal.

If the generator is set to *Hold* mode, the EOR gate will stay high for the falling stage plus any previous hold value. It will thus vary according to the input gate.

2.5.2 End of Fall (EOF)

If the generator is set to *Transient* or *Hold*, the EOF will stay high as long as the envelope is idling, from the

end of the falling stage until the beginning of the rising one.

If the generator is set to *Loop*, the EOF will output a fast burst between the end of a cycle and the beginning of the new one. It will be an actual trigger.

2.6 ADDITIONAL GENERATOR FEATURES

2.6.1 Quadrature

The *Quadrature* switch (E.2) enables the quadrature mode when moved to the right. *Quadrature* is a particular function that allows chaining the stages of both generators to obtain more complex functions. You may want to think of it as a couple of envelopes whose stages are interdependent.

Here is the sequence:

- begin of cycle → yellow starts to rise;
- yellow rise ends → green starts to rise/yellow in hold;
- green rise ends → yellow starts to fall/green in hold;
- yellow fall ends → green starts to fall/yellow in rest;
- green fall ends → end of cycle.

To achieve quadrature, move the *Quadrature* switch to the right, and set the green generator in *Hold* mode. You may now achieve three kinds of results, basing on the yellow generator's mode in use:

- *Yellow in Loop*: a looping quadrature, which automatically restarts from the yellow *rise* stage when the green ends its *fall*;

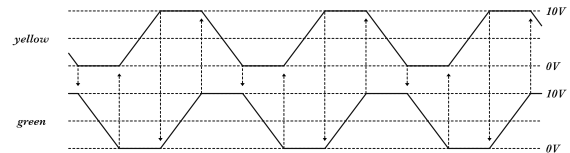

Figure 45: Quadrature mode with the same yellow and green times.

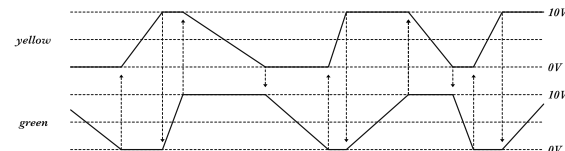

Figure 46: Quadrature mode with different yellow and green times.

- *Yellow in Transient*: a single-shot quadrature cycle;

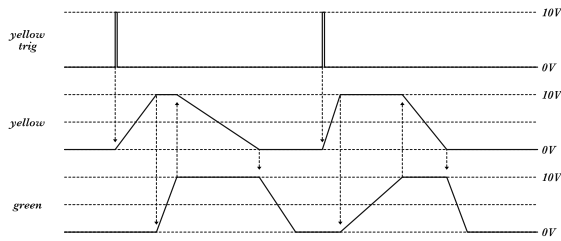

Figure 47: FALISTRi's *Quadrature*, yellow generator in *Transient* mode.

- Yellow in *Hold*: a single shot quadrature cycle, whose yellow hold stage depends on both green rise time and the length of the impulse/gate used to trigger the yellow generator.

As described in the *Green Retrigger* section (§2.2.1), the quadrature mode deactivates the retrigger mode *On Rest* for the green generator.

2.6.2 Max

The *Max* section outputs the higher value between the two attenuverted signals (also called *Analog OR* in some synthesizers). It is particularly useful to combine the yellow and green functions in order to achieve more complex envelopes or unconventional wave shapes.

2.6.2.1 ADSR

With *Quadrature* enabled it is possible to obtain envelopes such as ADSR (Attack-Decay-Sustain-Release)/AHDSR (Attack-Hold-Decay-Sustain-Release) by using the *Max output* (E.1) and the *attenuverters* (A.7) to set the relative levels.

The *Attack* is performed by the yellow *Rise*.

The *Hold* time, when needed, is determined by both the green *Rise* time and the yellow *Hold* time (when the yellow generator is in *Hold* mode).

When the yellow *Fall* starts, the green generator enters the *Hold* stage until the yellow envelope reaches its end. The green *Hold* level is set by its *Attenuverter* (A.7).

As long as the yellow *Fall* level is higher than the green *Hold* one, the envelope will be in its *Decay* stage. When the green *Hold* stage level is higher than the yellow *Fall*, the envelope will be in its *Sustain* stage, whose duration is set by the yellow *Fall* time.

When the yellow *Fall* reaches its end, the envelope begins its *Release* stage, which is set by the green *Fall* time.

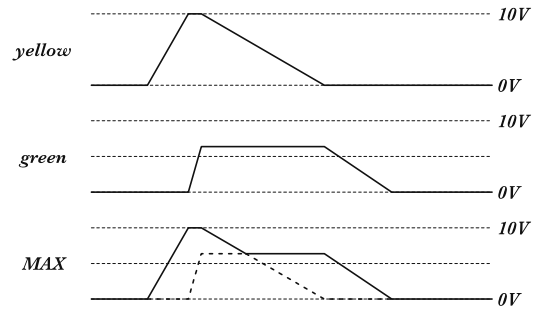

Figure 48: AHDSR envelope with FALISTRi's *Quadrature*.



Practice the *Quadrature* mode and the *Max* output with these *Techniques*:

- [Quadrature #1](#)
- [Complex Envelopes #1](#)
- [Accents #1](#)
- [Bouncing Ball](#)

3 FUNCTION PROCESSORS

3.1 DUAL CASCADED FREQUENCY DIVIDER

This section contains two frequency-dividing circuits, also known as flip/flops or sub-octave processors. They change their logic state whenever a low-to-high transition passes through their input. In other words, it needs two gate-high signal inputs to generate one gate-high output, so it divides by two the number of state changes passing through it.

The top left jack sockets (D.1, D.2) are inputs, and the bottom right ones (D.3, D.4) are outputs. The first circuit is the top one, the second circuit is the bottom one.

The two sections are semi-normalled in order to achieve 1/2 and 1/4 outputs from a single input. Output *Range* switches (D.5, D.6) are useful to obtain unipolar (0 V/+10 V) when the switch is high or bipolar signals (± 5 V) when the switch is low.

When an audio signal is used as input, it works as a sub-octave generator (we recommend a square or pulse wave). When the input is a clock, the circuit works as a clock divider. Bear in mind that if the input is a trigger, the output is always a gate, since the flip flop retains its state (high or low) until it detects a new rising edge at its input.

Random clocks from SAPÈL create interesting variable-length sequences of gates.

The following example uses a clock as input, obtaining half and a quarter of that clock frequency.

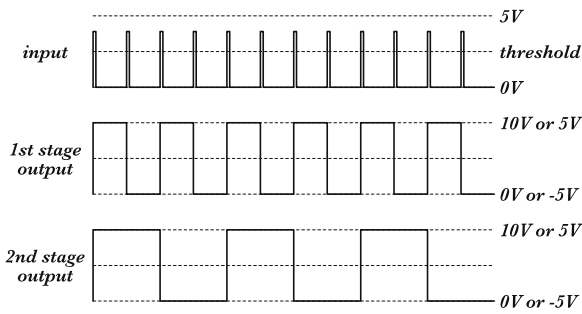

Figure 49: FALISTRi's DCFD as a double clock divider.

The following example uses a random clock stream as input.

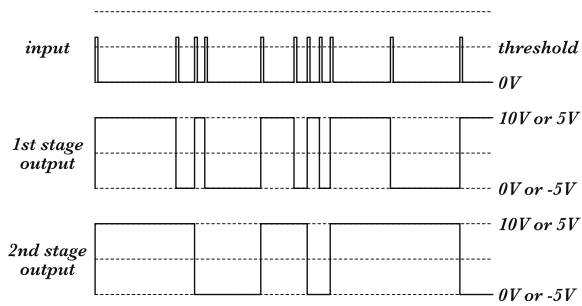

Figure 50: FALISTRi's DCFD as a random flip-flop.

This last example uses a square-ish wave as audio rate source, obtaining -1 and -2 octave as output.

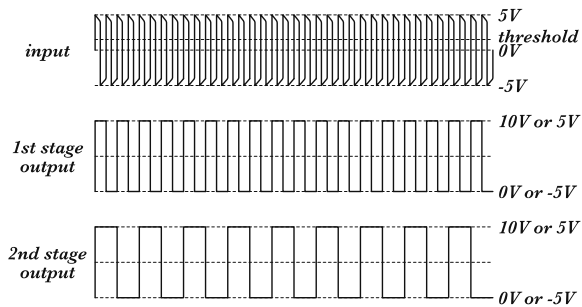

Figure 51: FALISTRi's DCFD as a sub-octave generator.



Practice the DCFD with these Techniques:
[Ratcheting-Like Effect #1](#)
[Octave Blends](#)

3.2 FOUR-QUADRANT MULTIPLIER

The *Four-Quadrant Multiplier* (4QM) is a circuit that multiplies two signals by one each other. It is similar to a VCA, with the main difference being that it accepts bipolar signals on both inputs, allowing any possible combination of positive and negative polarities, which can be thought of as the four quadrants (hence its name) of a

two-dimensional Cartesian plane. It can be thought of as a ring modulator, a balanced modulator, a through-zero VCA, or, more simply, a voltage-controlled attenuverter.

With exceptional linearity and a bandwidth from DC to more than 20 KHz, the result of this operation is completely up to the sources in use.

The two inlets are the jack sockets on the left: the first from the top (B.1) is semi-normalled to the yellow unipolar output; the second (B.2) is semi-normalled to the green bipolar one: in this way you can use the yellow as an envelope and the green as an audio source, without patching any cable.

The *Level* knob (B.3) sets the amount of the two signals, affecting the *Output* as a whole (B.4).

The four-led matrix shows which of the quadrant is currently in use: *Input 1* (B.1) moves the lights vertically (negative bottom, positive top), and *Input 2* (B.2) moves the lights horizontally (negative left, positive right).

3.2.1 Amplitude Modulation & Ring Modulation (2 vs 4 quadrants)

When one of the signals is bipolar and the other is unipolar, the 4QM works like an actual linear VCA: this is the default behavior. It means that if, for example, the green generator is working as an oscillator, the yellow one controls its amplitude.



This configuration allows you to use FALISTRi as a simple, yet effective synth voice. Practice this Technique:
[Synth Voice](#)

If the yellow generator too is brought to audio rate, FALISTRi starts to perform amplitude modulation (AM), also called unbalanced modulation because one of the two signals is positive-only and only two of the four quadrants of our hypothetical Cartesian plane are in use.

In case both signals are bipolar, FALISTRi starts to perform the so-called Ring Modulation (RM), or 'balanced modulation' because it uses all the four quadrants (i.e., the combinations of positive and negative polarities). On AM and RM, see section 8 of the *Modular Synthesis: Core Concept* chapter, page 12.



Practice AM and RM with this Technique:
[VCA/AM/RM](#)

If you patch two unipolar signals, you'll use just one quadrant, thus obtaining a sort of analog and:
[Fake Analog And](#)

3.2.2 Trimming

The front panel features a trimmer in the 4QM area. This may be useful to set the zero level when used with a

unipolar envelope that falls at zero, reducing possible DC offset that would cause a lower attenuation. By default, it is trimmed with the yellow unipolar signal.

3.3 LINEAR SLEW LIMITER

Also known as *portamento* or *glide* when using a quantized CV, this processor comes into play when any voltage smoothing is needed. This section smoothens any kind of voltage transition with independent controls over the rising and falling edges of the incoming signal.

The pot on the left (C.2) sets the slew of the rising voltages patched to its input (C.1), while the pot on the right (C.3) of the falling ones. The result is routed to the *Output*

(C.4) The two LEDs are also helpful to display what is happening under the hood.

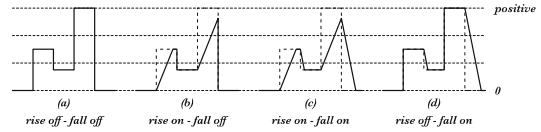

Figure 52: Linear slew limiting.



Practice this tool with the following Technique:
[Pitch Smoothing](#)

4 TECHNICAL DATA

4.1 REVISIONS

Starting from lot no. 201001 until lot 211201 we rearranged the board layout to facilitate the calibration procedure in the lab. The functions of the module and its tech specs have not been changed.

Starting from lot no. 220101 we rearranged the board layout to facilitate the calibration procedure in the lab. The functions of the module and its tech specs have not been changed.

4.2 SPECIFICATIONS

Parameter	Details	Min	Typ	Max	Unit	
Size			18		HP	
Depth			38		mm	
Current Draw		+12 V		170	mA	
		-12 V		170		
Recommended warmup time			30		min	
CV input impedance			> 90		K Ω	
CV input range	Attack/Release	Usable voltages	-10	10	V	
		Absolute knob offset		15	V	
Trigger/Gate Input	Input Trigger Threshold	Amplitude		> 1.5	V	
		Maximum Frequency (at 1.5 V)		> 6	KHz	
		Minimum Pulse Period		< 80	μ s	
		Impedance		> 90	K Ω	
Loop input	Input Trigger Threshold	Amplitude		> 3	V	
		Maximum Frequency (at 3V)		> 6	KHz	
		Minimum Pulse Period		< 80	μ s	
		Impedance		> 50	K Ω	
Times & Frequencies	Single stage (Rise or Fall) with Long Times	from		0.9	ms	
		to	> 8	10	s	
	Complete Cycle with Long Times	from		1.9	ms	
				520	Hz	
		to	> 16	20	s	
	Complete Cycle with Short Times		< 0.06	0.05	Hz	
		from		0.16	ms	
				6.1	KHz	
		to	> 1	1.5	s	
			< 1Hz	0.67	Hz	
Generators Voltages Output	Unipolar Amplitude		> 10	V		
	Bipolar Amplitude		> \pm 5	V		
	Unipolar Offset (in Rest)			< 35	mV	
	Impedance		> 100		Ω	
	Waveshapers amplitude tolerance (e.g. overshoot)			< 1	%	
Generators V/oct Tracking	Audible range		< \pm 5	ϵ		
MAX output	Impedance		> 100		Ω	
Generators Gate Output	Amplitude		> 10	V		
	Offset	-20		20	mV	
	EOF min positive pulse period		1		ms	
	Impedance		> 220		Ω	
	Frequency dividers	Input Trigger Threshold	Amplitude		> 3	V
Maximum Frequency (at 3V)				40	KHz	
Minimum Pulse Period				< 10	μ s	
Output		Unipolar amplitude (high)		~9.5		V
		Bipolar Amplitude		> \pm 4.5		V
Impedance		Input		> 90		K Ω
		Output		> 220		Ω
Four Quadrant Multiplier	Dynamic Range (1)(2)		75	78	dB	
	Residual THD+N (1)			0.015	0.02	%
	Maximum Allowable Gain (1)(3)		6	6.5	7	dB
	High Frequency Roll Off	-3 dB		36		KHz
	Impedance	Input		> 90		K Ω
Output			> 100		Ω	
Slew Limiter	Slew Rate	Minimum		1	1.25	V/ms
		Maximum		0.5	0.6	0.7
	Impedance	Input		> 28		K Ω
		Output		> 100		Ω

(1) Using a DC on one input and a sine wave at 2.4 KHz at 3V rms on the other. Pot fully clockwise.

(2) Filtered with 30 KHz LPF and 400 Hz HPF.

(3) 10 Hz=80 KHz

USTA

(Refer to firmware v. 155)

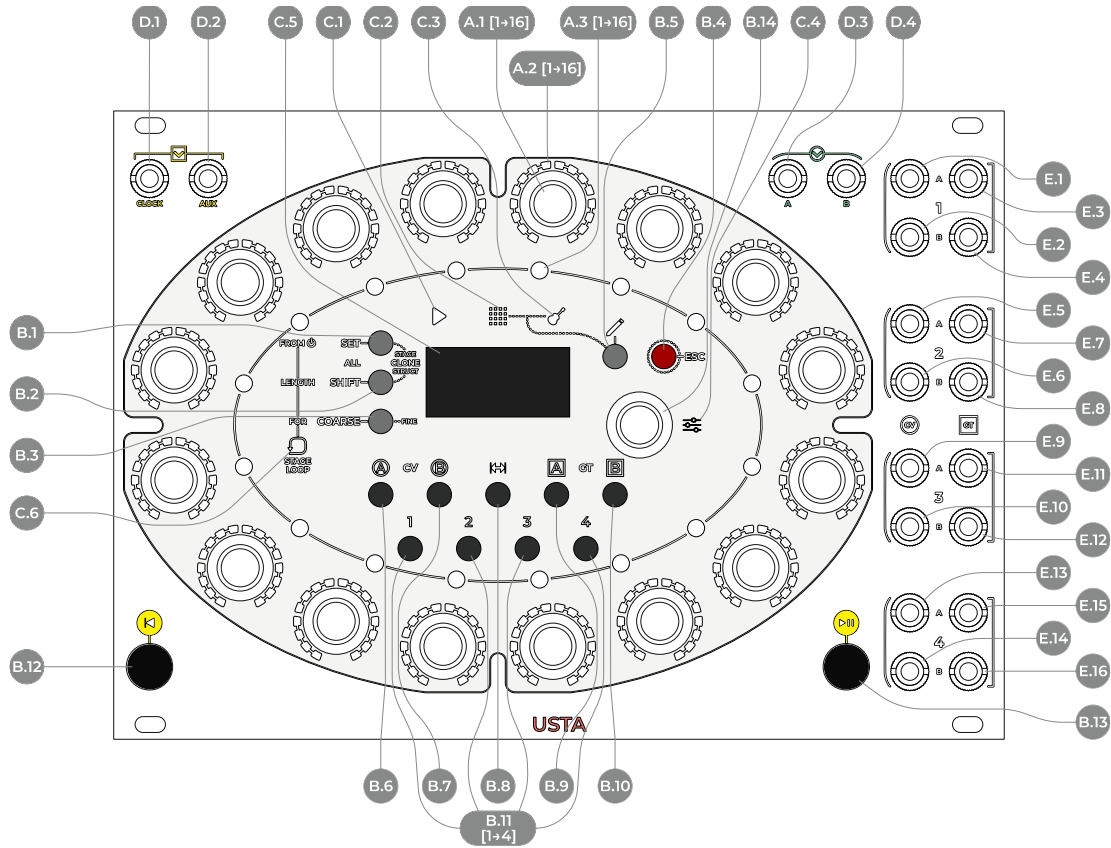

Figure 53: USTA interface.

A Stages

A.1 Stage Encoders [1→16]

A.2 Stage Arc

A.3 Stage RGB LEDs

B Buttons and LEDs

B.1 Set All

B.2 Shift All

B.3 Coarse

B.4 Esc

B.5 Pencil Button and LED

B.6 CV A button and LED

B.7 CV B button and LED

B.8 Length button and LED

B.9 Gate A button and LED

B.10 Gate B button and LED

B.11 Track buttons and LEDs [1→4]

B.12 Reset

B.13 Play

B.14 Navigation Encoder

C Other Visual References

C.1 Play LED

C.2 Pattern LED

C.3 Song LED

C.4 Menu LED

C.5 7-Segment OLED Display

C.6 Stage Loop LED

D Inputs

D.1 Clock Input

D.2 Auxiliary Gate Input

D.3 CV A Input

D.4 CV B Input

E Outputs

E.1 Track 1 – CV A

E.2 Track 1 – CV B

E.3 Track 1 – Gate A

E.4 Track 1 – Gate B

E.5 Track 2 – CV A

E.6 Track 2 – CV B

E.7 Track 2 – Gate A

E.8 Track 2 – Gate B

E.9 Track 3 – CV A

E.10 Track 3 – CV B

E.11 Track 3 – Gate A

E.12 Track 3 – Gate B

E.13 Track 4 – CV A

E.14 Track 4 – CV B

E.15 Track 4 – Gate A

E.16 Track 4 – Gate B

1 QUICK START

Once you have installed USTA and powered up your system, you will see a fast boot screen with the Frap Tools logo on the OLED Display (C.5), then a screen with various details concerning the project you are about to

create. *Track 1* (B.11) and its *CV A* (B.6) are already selected and ready to be edited.

Start rotating the 16 encoders (A.1) and you will see that the LEDs surrounding them (A.2) are progressively lighting up, and at the same time, a changing note name appears in the lower-left corner of the Display, indicating

the pitch of the selected stage of the sequence. This is the content of the sequence, which will be outputted by the *CVA* jack port of the first track (E.1).

Patch it to the 1V/oct input of your oscillator and then push the *Play* button (B.13) to hear the sequence.

Now you may need gate signals to separate the notes and add dynamics to your sequence. Push the Gate A button (B.9) to access the *Gate Channel* and rotate the *Stage Encoder* (A.1) as before.

You are now defining the individual gate-high time for each of the 16 notes you entered. Patch the *Gate A* output of Track 1 (E.3) e.g. to an envelope controlling the VCA, or the filter.

What you just obtained is a sequence of 16 notes with equal duration. Feel like something is missing? It actually is. To learn how to work with full polyphony, have faster or slower sequences at the same time, change the length of the notes, make a single note vary every time it is played, but still in the key you chose, have some random ratcheting on a given stage, loop a section within a song structure, and many other things, please take a deep breath and keep reading.

2 PHILOSOPHY AND DESIGN

USTA is a 4×4-tracks variable-stage-length sequencer for voltages and gates.

Variable stage length means that every single stage duration can be individually set in relation to the clock, instead of being constrained to a one-to-one ratio (i.e., one step per every clock impulse).

4×4-tracks means that every *stage* can store and generate up to four separate voltages (two CV and two gates) and that up to four independent sequences can be arranged as simultaneous tracks.

USTA's user interface is based on a straightforward 16-stage circular design with an array of multi-functional pushable encoders and buttons. This allows users to easily navigate within the sequencer's flexible software architecture and to quickly display and edit relationships between the different stages.

Those main features are what makes USTA the Euro-rack *Voltage Score*: its flexibility on the time, rhythm, and harmony domain, its large set of independent outputs, and its performance-oriented interface allow the user to achieve nearly any musical result, from fine Baroque polyphony to the most extreme polyrhythmic noise live performance.

2.1 ARCHITECTURE

USTA's architecture is designed to provide a wide set of compositional tools without sacrificing user-friendliness.

The smallest “brick” of the sequencer is the *stage*, which contains two separate control voltage values, two separate gate values, and all the behavioral information necessary to generate four synchronous musical events, including pitch, volume, timbre, repetition, probability...

A sequence of up to 16 stages (one per encoder) forms a *pattern*, in the same way that a series of individual musical events forms a melody.

Up to 32 patterns are contained in a *track*, which can be compared to a musical piece for a solo instrument. Besides all the melodic content stored in a pattern, a track also contains the performance information, including which pattern is currently playing, which external control is used as a modulator, and so on. Four tracks are simultaneously available in USTA, and they can have different tempos, number of stages, and patterns.

Just like any musical piece, the track can be either improvised, when the musician decides all these performance details on the go, or carefully composed first, and then played back: to accomplish this last task, USTA allows an alternative playing mode called *song*, in which all the patterns can be arranged in a pre-determined set.

This information can be independently set per each of USTA's four tracks. All four tracks along with their data and information are contained in a *project*, which is the general operational framework of the sequencer. A project can be stored on the included micro-SD and recalled whenever needed (one project at a time). On the first startup an empty project is created (called **NONAME**), then at every other startup USTA automatically will recall the last opened project, according to how it was saved. Projects and trimming settings can be backed up on your computer from the micro-SD.

2.2 TEMPO MANAGEMENT

Conventional step sequencers use the reference clock to jump from one step to the other. This means that the step duration, which is the time from one step to the other, corresponds to the period between consecutive clock impulses.

USTA, on the other hand, allows every stage to have a different length that can be set in relation to the reference clock (and this is one reason why the term *stage* is preferred over *step*).

Such relation is achieved through two deeply connected concepts: *time units* and *time ratio*. The *unit* is the shortest possible duration of a given stage, while the *ratio* defines the unit length in respect of the clock tempo.

It is possible to have 16 different time ratios: 8 are clock divisions, thus providing units that are longer than the clock impulses; 7 are clock multiplications, thus providing units that are shorter than the clock impulses; one is the exact clock period, thus providing units that are as long as the clock impulses.

The following chart displays the clock-to-unit ratios available: on the left is the number of clocks, on the right is the number of units.

24:1	
8:1	
7:1	
6:1	Clock division (n clock impulses per 1 unit)
5:1	
4:1	
3:1	
2:1	
<hr/>	
1:1	1 clock impulse per 1 unit
1:2	
1:3	
1:4	
1:5	Clock multiplication (1 clock impulse per n units)
1:6	
1:7	
1:8	

Table 6: Clock-to-unit ratio

Each *stage length* can measure from 0 to 16 units, where 0 means the stage has no length in the time domain and will thus skip.

The combination of time ratio and units allows extremely flexible sequences of stages. For example, with the same clock, it is possible to achieve fast 16th sequences if the time ratio is set to 1:4 and the stage duration is set to 1 unit, or slow sequences of whole notes if the time ratio is set to 2:1 and the stage duration is set to 4 units. It is also possible to have extremely slow sequences by cranking up the stage length to 16 units and the ratio to 24:1.

Another benefit of USTA’s architecture is the efficient use of stages to create melodies: in the image below, the melody (a) needs 16 steps and four gates to be performed on a standard step sequencer with a regular clock (b), while on USTA it takes only four stages, one per each musical event (or “note”), each one with its relative duration and gate (c).

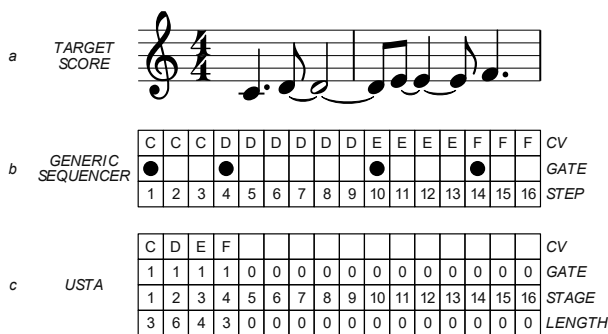

Figure 54: Step versus stage sequencing.

3 BASIC EDITING AND VISUAL FEEDBACK

The interaction between the musician and USTA happens both through the navigation menu and more “manual” operations such as button and encoder combinations. Likewise, the visual feedback combines the color-coded LEDs and the information provided by the default screen on the display (C.5), called *Dashboard*.

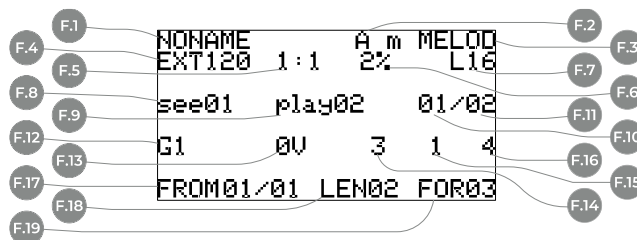

Figure 55: USTA’s *Dashboard*.

- | | | | |
|------------|--------------------------|-------------|-------------------|
| F | Dashboard | F.10 | First pattern |
| F.1 | Project Name | F.11 | Last pattern |
| F.2 | Root Note | F.12 | CV A value |
| F.3 | Scale | F.13 | CV B value |
| F.4 | Clock Source and BPM/PPM | F.14 | Length Value |
| F.5 | Time Ratio | F.15 | Gate A value |
| F.6 | Swing | F.16 | Gate B value |
| F.7 | Total pattern length | F.17 | Stage Loop From |
| F.8 | Selected pattern | F.18 | Stage Loop Length |
| F.9 | Playing pattern | F.19 | Stage Loop For |

As a rule of thumb, all the data regarding the general behavior of USTA (track settings) are accessed through the *Project Menu* and *Track Menu* (see below, §§ 3.1-3.2), while all the data concerning the very musical content, such as individual stage data, are set via dedicated encoders and buttons (§ 3.3 below).

3.1 EDITING PROJECTS – PROJECT MENU

On its first boot, USTA automatically creates an empty project called `NONAME`, which is ready to be edited. All the live editing is stored in a volatile memory that resets at shutdown, but the edited project can be permanently saved into an SD card. To perform these tasks, push and hold the navigation encoder (B.14) for three seconds until the *Menu LED* (C.4) lights up red: this will open the project menu.



Figure 56: Project Menu LED.

Once there, rotate the same encoder to navigate through the menu items, and push it to select the desired one.

It is possible to perform five operations concerning projects:

New...	create a new project, which will be called NONAME
Save as...	save the current project with a new name
Load...	load a previously saved project;
Save	save the current project
Delete...	delete a previously saved project
Rename...	change the name of a previously saved project.

When performing tasks such as **Load...**, **Delete...** or **Rename...**, a new window will open with all the saved projects: rotate the navigation encoder to select the desired project and push it to perform the desired task.

When saving the project as a new one, or when renaming an existing one, a new window will open to let you type in the new name. You will notice an angle bracket after the last character of the name (<): it is the *delete* symbol, and when it is present you may press the encoder to delete a letter or number.

To add a new character, rotate the encoder and skim through the alphabetical series. Push the encoder again to confirm and move on to the next character. Once the new letter is confirmed, the *delete* symbol will appear again and it will be possible to delete the last entered character.

Once the name is set, press the *Play* button (B.13) to save it and the *Reset* to cancel the operation.

These operations are not designed for live performance; still, they can be easily performed while USTA is playing, without major issues. In case a project is saved while USTA is playing, the machine temporarily freezes on the current step, then gets back to play. When loading a project while playing, USTA does not stop, but all the user interface elements (LEDs, OLED screen, RGB LEDs, and Stage Arc) are momentarily disabled for half a second. During these operations, USTA might slightly slow down or even miss a clock impulse when using an external clock, with direct consequences on the Clock-to-Unit Ratio calculation. Please note that you cannot rename a freshly created project unless you save it first.

A high number of projects can be stored in USTA's microSD, but only the first 128 projects in alphabetical order will be used/recalled.

Once you are done editing the project, press Esc to return to the dashboard: the name of the selected project will then be shown in the top section (F.1).

If you happen to select **Save** instead of **Save as...** USTA will automatically save your current project as NONAME; however, this procedure is not recommended since any other project accidentally saved as NONAME will overwrite this last one.

3.2 EDITING TRACKS – TRACK MENU

Once a new project is created, you can start to compose or improvise. USTA allows you to edit one track at a time. Track 1 is selected by default: to select another track, press one of the four *Track Buttons* (B.11).

Once the desired track is selected, the LED above its button will light up green. At this point, USTA's interface displays the information relative to the selected track and it is possible to play or edit it.

3.2.1 Clock Settings

To set the clock, push once the *Navigation Encoder* (B.14) to access the track menu: the *Menu LED* (C.4) will light up green.

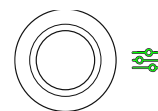

Figure 57: Track Menu LED

First, it is possible to choose whether your clock will follow an internal or external clock (see below § 7.1).

If you choose to have the selected track controlled by the internal clock, you shall then define the internal tempo (expressed in BPM) by editing the **Int BPM** parameter.

With firmware version 155 it became possible to “fine-tune” the clock by adding decimal values to the selected BPM number.

To do so, use the menu voice **Fine BPM** right below the **Int BPM** parameter: the number expresses BPM cents.

Practice the clock settings with these Techniques:



- [Clock and Ratio](#)
 - [Random-Clock Sequencing](#)
 - [USTA Multitempo #1](#)
 - [Clock Cross-Modulation #1](#)
 - [Clock Cross-Modulation #2](#)
 - [FALISTRI Clock Manipulation #1](#)
 - [FALISTRI Clock Manipulation #2](#)
-

Whether you choose to use an internal or external clock, you can select the time ratio on which USTA calculates the step unit through the **Ratio** parameter.



- Practice the use of clock ratios with this Technique:
 - [USTA Polyhythm #1](#)
-

If you want to apply the same *Track Menu* settings to all the tracks, hold the *Set All* button (B.1) before pushing the navigation encoder to save the setting (see below § 4.1).

Once you finished, press *Esc* (B.4) to exit the track menu and return to the dashboard: the information concerning BPM and time ratio is now displayed in the second row, right below the project name (F.4, F.5).

If you chose to use the internal clock, the tempo value is expressed in BPM, after the abbreviation *INT*; if you chose to use an external clock, patch it to the *Clock Input* (D.1): USTA will calculate its Pulses Per Minutes, which will be displayed on the *Dashboard* after the abbreviation *EXT*.

3.3 EDITING, PLAYING, AND LOOPING PATTERNS

Once the time dimension has been set, it is time to define the content of your track, that is to say, the *patterns*. 32 patterns are available per track, which can be edited one at a time. Please note that the patterns are not “created”: instead, they are always present in each track, with all the values set to 0, and ready to be edited. The default play mode of USTA is *Pattern Mode*, where a loop of patterns is played in numeric order. (It is possible to change this order through the *Song Mode*, on which see § 5.3) When a new project is created, only the first pattern is looping in *Pattern Mode*: let’s focus on this one for now.

Pattern Mode is displayed by the *Pattern LED* (C.2) when it’s lit up green.

USTA allows you to perform two main kinds of tasks with patterns: editing them and playing them back. These two operations can be performed separately (in a more “compositional” approach) or simultaneously (in an improvised performance), but always require two different operating modes, respectively called *Edit* and *Performance*.

These modes are accessed through the *Pencil* button (B.5), which switches from one to the other, and their status is displayed by the pencil-shaped LED: red when in *Edit* mode, and green when in *Performance*.

When the pencil LED is red, USTA is in edit mode, which is also the default setting once a project is created, and a track is selected. In this mode, you can modify whichever parameter you want.

As said above, it is also possible to play the sequence while editing: the visual feedback for the current stage playing is provided by a cyan stage RGB LED, called playhead. The playhead is displayed only when the selected pattern is playing. For example, when editing pattern 2, if pattern 2 is playing, the playhead is displayed, but if pattern 1 is playing, no playhead will be displayed.

In performance mode – the pencil RGB LED is green – the displayed pattern is always the one that is playing, according to the track: in this mode, it is no longer possible to edit patterns, but other operations are possible (see below § 5.4).

The third row of the *Dashboard* (Figure 55) displays all the information concerning the patterns that are currently being edited or played.

see (F.8) indicates the pattern that is currently selected for editing purposes. To select a pattern, make sure to be in *Edit Mode*, then rotate the *Navigation Encoder* (B.14). You will see this number changing accordingly.

play (F.9) indicates the pattern that is currently being played.

The two numbers separated by a slash indicate the beginning (F.10) and the ending point (F.11) of your pattern structure. By default, they are set to 01/01, which means that the pattern loop will be limited to the first pattern only. It is possible to edit any other pattern while pattern 1 is playing, however, the result of such an operation will not be heard unless the newly edited patterns are included within the pattern loop.

To change the extension of the pattern loop, enter *Performance Mode*, then hold the *Set All* button (B.1) and rotate the *Navigation Encoder* (B.14) to set the first pattern of your looping structure, or hold the *Shift All* button (B.2) while rotating the *Navigation Encoder* to set the last one. From now on, USTA will loop all the patterns contained within those two, including them.

Please note that the last pattern needs to be higher than the first pattern (or the same) because in *Pattern Mode* the playhead moves from one pattern to the other in numeric order. To obtain different pattern orders, please refer to the *Song Mode* (§ 5.3).

Another way of editing the pattern loop is through a button combination. When USTA is in *Performance mode*, every editing option is disabled: the 16 *Stage Encoders* (A.1) are now associated with the first 16 patterns, and while holding the *Shift All* button (B.2) they are associated with the last 16 patterns (or from the 17th to 32nd). They can be pushed to manually recall a given pattern (on which see *Pattern Recall*, § 5.4), but they can also be used to define the pattern loop on the fly. Push and hold the *Set All* button (B.1) and then push the encoders corresponding to the first and last patterns to set the new ends of the pattern loop: remember to hold also *Shift All* (B.2) to select patterns 17-32.

If you want to apply the same pattern loop settings (first and last pattern) to all the tracks at the same time, double-click *Shift All* when in *Performance Mode*.



Practice the Pattern Loop with these Techniques:
[Edit & Performance Mode](#)
[Pattern Loop](#)

3.4 EDITING STAGES

To modify the content of your pattern, you need to edit its stages. Each stage can have its *length*, expressed in terms of *units*.

Furthermore, each stage can store information for two separate control voltages and two gates, which form each stage's *channels*.













	Value	Variation Index	Variation Range
CV	 	 	 
GATE	 	 	 

Table 7: Channel LEDs

To access and modify these data, it is required to select the desired channel through the four *Channel Buttons* (B.6, B.7, B.9, B.10) or the *Length Button* (B.8) and then modify its value with the respective stage encoder (A.1). Each encoder corresponds to one and only one stage per pattern, numbered clockwise from the topmost one on the right.

Both CV and Gate channels have three different *layers* of data: *Value*, *Variation Index*, and *Variation Range*. By pressing a channel button (B.6, B.7, B.9, B.10) multiple times, the user cycles through its layers. The currently selected layer is indicated by the LED color above the channel button (see Table 7).

An arc of 16 yellow LEDs, the *Stage Arc* (A.2), provides visual feedback for the current value selected or edited for each stage. Furthermore, an RGB LED per each stage (A.3) provides information about the *stage color*, which defines the way a CV or gate is played (slide, freeze, ratchet, tie... see below §§ 3.4.3-3.4.5). This color is temporarily overwritten by the cyan *playhead* when that stage is played.

All the data of the stage which is currently being edited are also displayed in real-time in the fourth line from the top of the dashboard.

The five numbers are in the same order as the channel buttons: from left to right, they display the value of the last edited stage's *CV A* (F.12), *CV B* (F.13), *Length* (F.14), *Gate A* (F.15) and *Gate B* (F.16).

When entering *Performance Mode* (green *Pencil LED*, B.5), this row of the dashboard can be set to display, in real-time, the values of the stage that is currently being played (see below, § 3.4).

The four outputs per track are grouped on the right side of the front panel (E.1 to E.16). The number in each group refers to the track and the letters to the individual CV or Gate channels. As a rule of thumb, the symbols with a letter in a circle refer to CVs, while the ones with a letter in a square refer to gates.

Each pattern by default has a sequence of 16 stages with an equal length of one unit, whose speed depends on the

clock and the time ratio previously selected. First, let's edit the individual stage length.

3.4.1 Length

The *Length* section determines the duration of each stage in terms of *units* (see above), and it is accessed by pressing the *Length button* (B.8).

By default, the length of each stage is 1 unit. To increase it, turn the respective encoder (A.1) clockwise. Each step of the encoder increases the stage duration by 1 unit, up to a maximum value of 16: the *Stage Arc* (A.2) will light up accordingly, displaying the exact number of units per stage.

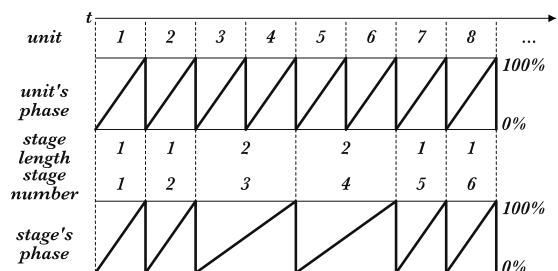

Figure 58: Stage Length and stage phase.

It is possible to turn the encoder counterclockwise until no LEDs are lit: in this case, the stage will have length 0, so it will be skipped during the playback.

When a given stage's length is being edited, the unit number is displayed also by the third digit from the left of the fourth line from the top of the dashboard (F.14).

The total length of a pattern is displayed at the right of the second row from the top, beside the letter L: this value may come in handy when you want to edit the length of two stages without changing the overall pattern length, as described in the following section.



Practice these basic concepts with the following Techniques: [CV, Gate, Length Stage Vs. Gate](#). Then, move on to a more complex patch with this one: [USTA Polymer #1](#)

3.4.1.1 Maintain Pattern Length on Variation

While performing it may be useful to hold the length of your pattern fixed while editing stage lengths. Adding or subtracting units can unintentionally shift the pattern's rhythm out of alignment. To reduce this chance, hold down the *Coarse button* (B.3) while changing the stage length. This causes a neighboring stage length to receive a compensating adjustment.

For example, assuming your pattern has only the first 4 stages with length 1 and the others with length 0, rotating

the stage 2 encoder clockwise will give stage 2 a 2-unit length for a pattern length of 5 units. Rotating the encoder counterclockwise gives stage 2 a 0-length stage, resulting in a 3-unit length pattern. If these steps are performed while the *Coarse* button is held down, the clockwise rotation will increase the stage 2 length to 2, but the 3rd stage will be reduced to length 0 to compensate. Likewise, a counterclockwise rotation will decrease the stage 2 length to 0, while the 3rd stage will be increased to length 2. In both cases, the pattern length of 4 units is retained.

3.4.2 CV Layers

The CV channels' parameters can be modified through three different *layers*, which are accessed by pressing the respective channel button (B.6, B.7) multiple times.

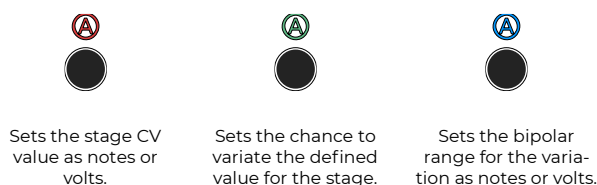

Table 8: CV Layers Comparison.

The first layer is marked by a red LED and determines the CV value (such as the pitch), while the second and third layers (respectively marked by green and blue LEDs) manage possible variations of the red layer's value.

3.4.2.1 Red CV Layer: Value



Figure 59: CV A's Value layer is selected.

The red layer is displayed by default once a channel is selected. It contains the data concerning the stage *value* (i.e., the actual voltage that will be output by USTA).

Such values can be quantized (as in 12 semitones) or raw (i.e., continuous voltages with down to 1 mV of resolution). The default setting is *Pitch* for *CV A*, which can be used for generating melodic lines, and *Raw* for *CV B*, which can thus be used to add dynamics and to modulate other “musical” parameters such as filters, VCAs, timbre... It is possible to change these settings and have both CVs in raw or quantized mode (see below § 8.1).

To edit this value, select the desired channel (*CV A* or *CV B*) through its button (B.6, B.7), then rotate the encoder corresponding to the step you want to edit (A.1). Each time you edit a stage value, the fourth row from the top of the dashboard updates showing the *CV A*, *CV B*, *Length*, *Gate A*, and *Gate B* for that stage on that pattern of

that track: this is helpful to understand relationships of the same stage across channels.

Pitch CV channels display notes using the standard notation letters from A to G followed by the octave number, while *Raw* CV channels display Volts. The octave number can be set to change on A or C through the reference note (see below § 9.4).

In *Pitch* mode, the *Stage Arc* (A.2) will also precisely display the selected note. 12 LEDs from left to right display the note value in half steps: none for C, one for C#/D^b, and so on until eleven lit LEDs stand for B. The note references apply when the project reference note is C. To change it to A (see below § 9.4). The four remaining LEDs will display the octave, from right to left. For a precise chart of this visualization system see *LED Pitch Tables*, §9.6.

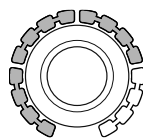

Figure 60: The grey LEDs display the semitones.

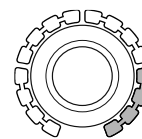

Figure 61: The grey LEDs display the octaves.

By default, USTA works with the 12-semitone equal temperament, which divides the octave into 12 equally spaced intervals. It is possible, however, to change this setting and work with other more complex octave divisions such as 15, 19, 22, or 24 intervals, on which see below § 9.2.

For raw channels, such as channel *CV B* by default, the encoder increases the stage CV value by steps of 0.05 V or 50 mV when turned clockwise. In this mode, coarse and fine editing is possible: with the *Coarse* button held down, the encoder steps are 0.5 V (500 mV), while with the fine (*Esc* held down and *Coarse* held down) steps are 0.001 V (1 mV). Visual feedback of the value is displayed on the 16 yellow LED of each *Stage Arc*, scaling the 10 V of range to 0/16 LED: in other words, each LED shows 0.625 V.



Practice the *Raw* voltages with this Technique: [Raw CV](#)

3.4.2.2 Green CV Layer: Variation Index



Figure 62: CV A's Variation Index layer is selected.

The green layer is accessed by pressing the channel button (B.6 or B.7) a second time: it controls the probability

that USTA will shift the red value up or down in a given bipolar range (see below, Blue CV Layer).

By default, the stage values are at 0, with the *Stage Arc* (A.2) completely off: this means that there is no chance that the note (or voltage) will change, so USTA will stick to the value assigned in the red layer.

By turning the *Stage Encoders* (A.1) clockwise, you increase the chance that the note will be replaced with another one (*Variation Index*), picked by a pool of values whose range is defined by the blue layer (*Variation Range*, see the following chapter). In this mode, USTA tosses a coin at every stage with an *Index* bigger than 0 and decides whether the stage will pick the *Value* defined in the red layer or shift it.

When 8 LEDs out of 16 of the *Stage Arc* are lit up, the chances are 50-50: the probability that the defined value will be played or not is the same. When all 16 LEDs are lit, another note or voltage will certainly be evaluated.

It does not mean, however, that the *Value* defined in the red layer will not play at all, since it is still within the *Variation Range* defined by the blue layer, so it might be picked by the coin toss.

3.4.2.3 Blue CV Layer: Variation Range



Figure 63: CV A's *Variation Range* layer is selected.

The blue layer is accessed by pressing the channel button (B.6 or B.7) a third time: it determines the range of values which the variation index will refer to (the *Variation Range*, i.e., the values that may or may not be “picked” by USTA instead of the one defined in the red layer).

The blue layer lets you choose the bipolar range of values that could be selected by USTA after tossing the coin. Such values are expressed in semitones for the *Pitch* channels and millivolts for the *Raw* ones. The range increments by steps of ± 2 semitones each for the quantized channels (up to ± 32 semitones) and in steps of ± 314 mV each for the raw channels (up to ± 5.024 V).

While some extreme settings of the green and blue layer might translate into a behavior comparable to the one of a random voltage generator such as SAPÈL, their overall approach is completely different, if not the opposite. SAPÈL is a true random module whose voltages are sampled using analog noise as a source, therefore there is no chance that a sequence of values will repeat itself over time. USTA, on the other hand, uses a digital “coin toss” algorithm to randomly pick a value within a given range defined by the user, whose result depends on the *Value* chosen as default. In other words, while SAPÈL shapes its stream of random voltages by “subtraction”, i.e., through sample-and-hold, quantization, and probability

distribution, USTA progressively “expands” the range of values according to the musician’s instructions.

3.4.3 CV Stage Colors

Each stage can be played in three different ways called *Stage Colors*, which can be accessed by pushing the *Stage Encoder* (A.1) multiple times. To better understand the relationship between *Stage Colors* and the *Layers* described in the previous chapters, one could say that *Layers* affect the *content*, i.e., the values that the stage will play, while *Colors* affect the *form*, i.e., the how such values will be played.

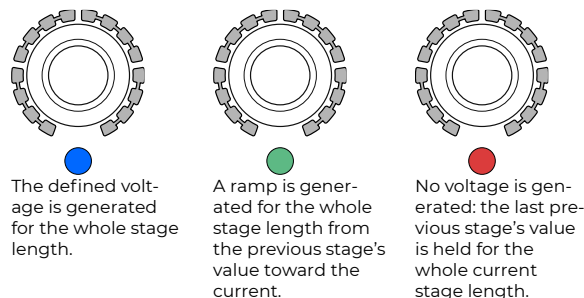

Table 9: CV Colors comparison.

The first CV *Stage Color*, called *Flat*, is selected by default once a channel (*CV A* or *CV B*) is selected, and it is indicated by a blue *Stage LED* (A.3). It simply plays the stage value (whether selected or randomly shifted) for the whole stage duration. It is the normal behavior you would expect from a traditional sequencer.

The second CV *Stage Color*, called *Slide*, is accessed by pushing the *Stage Encoder* (A.1) once, and it is indicated by a green *Stage LED*. In this mode, instead of playing the defined stage value, USTA will automatically generate a linear ramp from the previous value to the new one, in a sort of “glide” effect, interpolated for the whole length of the stage.

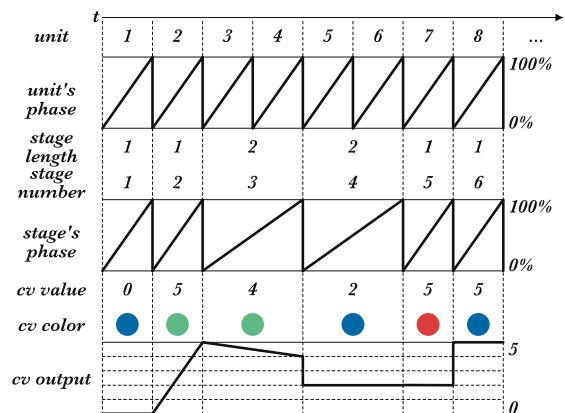

Figure 64: Unit phase, *Stage* phase, and CV output.

The third CV stage color, called *Skip*, is accessed by pushing the *Stage Encoder* a second time, and it is indicated

by a red stage LED. In this mode the stage skips the voltage generation, retaining its length (see below): USTA will simply play the last value generated by the previous stage.

Push the *Stage Encoder* again to return to the blue color layer.



Practice the CV Layers and CV Colors with these Techniques:
[CV Colors](#)
[CV Variation](#)
[USTA Envelopes #1](#)
[USTA Envelopes #2](#)

3.4.3.1 USTA Slide vs FALISTRIS Slew

The slide color may be similar to a slew limiter circuit (see FALISTRIS § 3.3), but it is very different in design and concept. A slew limiter integrates two values and generates an ascending or descending ramp with a fixed duration (lag). Such lag time is arbitrarily set and often allows the target CV to be noticeably performed by the machine. USTA’s slide, on the other hand, automatically calculates the lag time, which corresponds to the whole stage duration. This means that the stage value set in the blue layer is technically never played, becoming the target point of an ascending or descending CV from the previous stage value. Please note that if the gate value is shorter than the stage length, the slide will not be heard in full. This allows for more subtle nuances while composing and can create some interesting results while blended with peculiar Gate settings: a fully open gate will add more dynamic to the composition, while a ratcheting effect will create an ascending sequence of shorter notes, similar to a complex embellishment.

3.4.4 Gate Layers

The other two outputs per track (E.3, E.4, E.7, E.8, E.11, E.12, E.15, E.16) are responsible for the gates. Just like in the CV channels, each stage can have three different *Layers* and three different *Gate Colors*. The first layer determines the number of gates that USTA will play within each stage, while the second and third layers add various degrees of variation to the red layer’s value, similar to the CV.

Sets the gate value.	Sets the chance to varyiate the defined stage's gate number.	Sets the bipolar range for the variation of the gate number.

Table 10: Gate Layers comparison.

3.4.4.1 Red Gate Layer: Value



Figure 65: Gate A's Value layer is selected.

The first layer is active by default. Once a gate channel is selected (B.9 or B.10), it is marked by a red RGB LED. It sets the “gate value”, which can be either the gate duration (if the stage color is blue) or the number of individual gates (ratcheting) that are generated within the stage length (if the stage color is green). See below § 3.4.5 for the *Gate Stage Colors*.

To edit the gate number, turn the desired *Stage Encoder* (A.1) clockwise: it will select a value from 1 to 16, which is displayed by the Stage Arc surrounding the encoder. It is possible to set the gate number to 0: in this case, no gate will be generated, and the output will remain low for the whole stage duration.

3.4.4.2 Green Gate Layer: Variation Index



Figure 66: Gate A's Variation Index layer is selected.

The second layer is accessed by pushing the channel button (B.9 or B.10) a second time and it is represented by a green LED: it controls the probability that USTA will randomly change the gate number, according to the range set in the blue (third) layer.

Gate Variation Index works similarly to the CV variation index layer (see above): the *Stage Encoder* (A.1), when rotated clockwise, will increase the chance that USTA will change the value selected in the red layer. By default, no LED is lit in the *Stage Arc* (A.2), therefore there is no chance that USTA will change the gate value. When half of the LEDs are lit, the chances of a variation are 50-50, and when all the LEDs are lit it is 100% sure that USTA will not play the selected gate value: it is still possible, however, that the previously defined gate value will be played again as a result of the coin toss, being it still within the *Variation Range* (see below).

3.4.4.3 Blue Gate Layer – Variation Range



Figure 67: Gate A's Variation Range Layer is selected.

The third layer is accessed by pushing the channel button (B.9 or B.10) a third time and it is represented by a blue LED: it determines the range of values that USTA will consider when changing the default value after the “coin toss” set by the green layer.

The *Gate Variation Range* layer selects the possible values that USTA can pick to vary the division of the stage length when the second layer probability is higher than zero. 16 numbers are possible, displayed by the *Stage Arc* (A.2) around the encoder. The default value is 0 (no LEDs are lit).

For instance, if the gate number in the red layer is 2, and a variation range of 8 is selected, USTA will pick a pseudo-random number between -6 ($2-8$) and 10 ($2+8$). Every negative result corresponds to a gate-off (i.e., a pause).

3.4.5 Gate Stage Colors

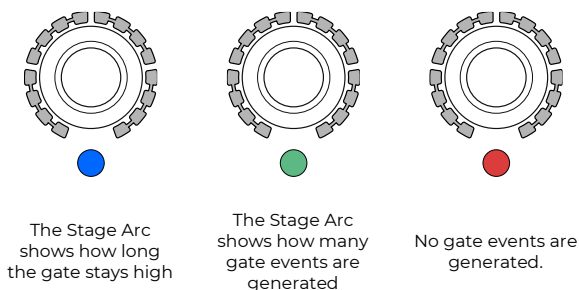

Table 11: Gate Colors comparison.

The first *Stage Color* is called *Gate Length*. *Gate Length* is available by default once a channel (*GATE A* or *GATE B*) is selected, indicated by a blue *Stage LED* (A.3). In this mode, the encoder sets the gate length, which is the portion of the overall stage in which the gate stays high. 17 lengths are available, indicated by the 16 LEDs of the *Stage Arc*. If no yellow LEDs are lit, the gate will remain low for the whole stage duration, which is the equivalent of a musical pause. By rotating the encoder clockwise, the gate length will be progressively increased, until all the 16 yellow LEDs are lit: in this position, the gate will remain high for the whole stage duration, and it will be tied to the next stage's gate. With the blue stage color selected, the Variation parameters set by the blue and green layers will modify the gate duration.

The second *Stage Color*, called *Gate Number*, is accessed by pushing the *Stage Encoder* (A.1) once, and it is displayed by a green *Stage LED*. In this mode, the encoder sets the number of gate events that will be generated within the overall stage length, which equals to a ratcheting effect. Again, 17 options are available, displayed by the 16 LEDs of the *Stage Arc*. If no yellow LED is lit, the gate will remain low for the whole stage duration, which is the equivalent of a musical pause. By rotating the *Stage Encoder* clockwise, the gate value will be progressively increased, until all the 16 yellow LEDs are lit. 1 LED means that 1 gate will be generated, and so on until 16 fast gates are outputted.

This division is performed by USTA based on the stage duration set by the length parameter, therefore, if the

gate number is 2, the individual gates will have different spacing and duration according to the stage length.

With the green stage color selected, the Variation parameters set by the blue and green layers will modify the gate numbers, thus creating a different number of gates (ratchet pattern).

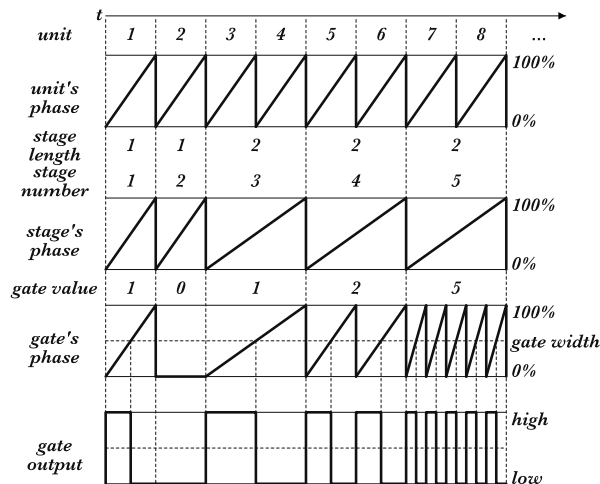

Figure 68: Gates in Repeat (green Color).



Practice the Gate Layers and Gate Colors with these Techniques:
[Gate Colors](#)
[Gate Variation](#)
[Wavefolder Ratcheting](#)
[USTA Polyrhythm #2](#)

The third *Color*, called *Skip*, is accessed by pushing the stage encoder a second time, and it is displayed by a red *Stage LED*. In this mode USTA will not generate any gate signal for the whole duration of the stage: it is the equivalent of a musical pause.

An identical effect can be obtained by setting the *Gate Value* to 0 (= no led on the LED Arc) either in the blue or green color; the *Skip* color, however, is useful in case you want to momentarily de-activate a stage while performing, while still retaining its specific *Gate Value*.

3.4.5.1 Setting the Ratcheting Gate Width

By default, with the green color the gate length is 50% of the time between two consecutive rising edges; it is possible to change this setting in the *Track Menu* (see above, § 3.2), under the *Gate Width %* option.



Practice the interaction of multiple tracks with these techniques:
[USTA Chords](#)

4 QUICK EDITING

Here are the functions that USTA provides to facilitate the compositional process. They are achieved through the three grey buttons to the left of the display, called *Mod Buttons*.

4.1 SET ALL AND SHIFT ALL

When in edit mode, the first two buttons allow you to edit multiple stages at the same time. Push them before rotating the stage encoders and hold them throughout the operation.

The topmost button, called *Set All* (B.1), allows you to set all stages in a pattern to the value of the stage being edited, regardless of their original value. It can be held while editing values (rotating the *Stage Encoder* – A.1) or colors (pushing the *Stage Encoder*), for CVs, Gates, and *Length*. It is also possible to hold the *Set All* button while setting *Track Menu* options through the *Navigation Encoder* (B.14): in this way, the setting will be applied to all four tracks at the same time.

The second button, called *Shift All* (B.2), works similarly but shifts all the stages by the same amount as the one being edited, thus transposing their values. Like *Set All*, this button works both for values (rotating the *Stage Encoder*) and colors (pushing the *Stage Encoder*). While shifting colors, all the following stages will change from one color to the next relative to their previous setting.

It is possible to change the *Shift All* behavior in the *Project Menu* (see above, § 3.1) through the **All Edits** option: select **From** to edit all the stages after the one which is being edited (it is particularly useful for quickly writing melodic lines); select **All** to edit all the stages of a pattern, including those before the one being edited.

4.2 COARSE AND FINE

In the *Value CV* layer (§ 3.4.2.1 above) it is possible to edit the stage values by increments of 1 octave or 1V (if the selected channel is working in *Pitch* or *Raw* voltages respectively): to do so, push and hold the *Coarse* button (B.3) while rotating the *Stage Encoder* (A.1) (see Figure 69).

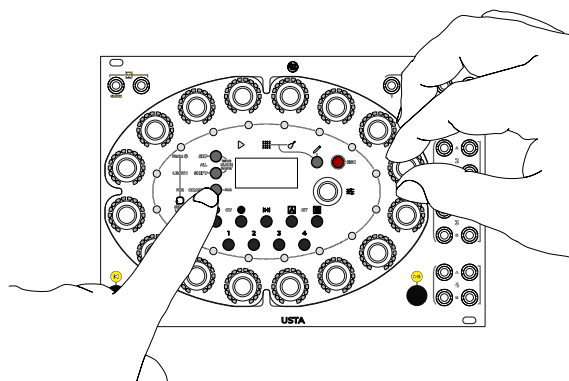

Figure 69: Coarse editing.

It is also possible to fine-tune the *Pitch* and *Raw* voltages. Hold pressed *Esc* (B.4) and then the *Coarse* button to access the *Fine* mode: now the *Stage Encoders* will change the

stage value by cents of a semitone in pitch mode and by milliVolts in raw mode.

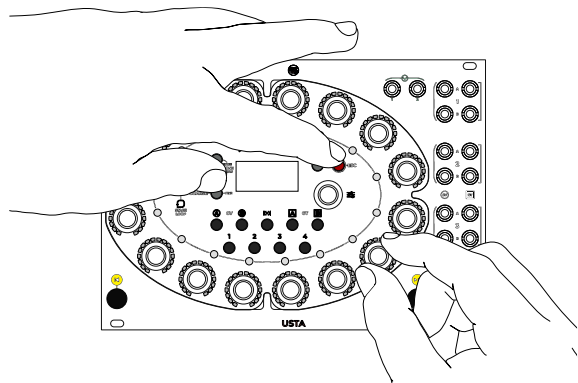

Figure 70: Fine editing.

4.3 COMBINING THE BUTTONS

It is possible to use the *Coarse/Fine* button (B.3) together with *Set All* (B.1) and *Shift All* (B.2) in order to perform tasks such as transposing the whole pattern by an octave or fine-tuning all the stages at once.



Practice the Mod Buttons with these Techniques:
[Set All and Shift All](#)
[Coarse and Fine Tuning](#)

5 PERFORMING

Once everything is set up according to your musical needs, you can start to perform with USTA.

5.1 PLAY/PAUSE, RESET, AND MASTER TRACK SETTINGS

In order to perform with USTA you need to start, pause and reset your sequence. Such controls are deeply connected and rely on the *Master* and *Slave* relationship between *Tracks*.

5.1.1 Master Track

The *Master Track* is the track other tracks refer to for play, pause, and reset purposes. The *Master/Slave* relationship is limited to these three operations: every other parameter such as tempo and time ratio will remain independent per each track. There can be only one *Master Track* for every project loaded into USTA.

To set the *Master Track*, enter the *Project Menu* by holding down the *Navigation Encoder* for three seconds (B.14), scroll to the *Master Track* option, and then select one of the four tracks. By default, a project's *Master Track* is track 1.

To subordinate a track to the *Master Track*, enter the *Track Menu* by pushing the *Navigation Encoder*, scroll to the

Reset On option, and set it on *Master*. By default, all the tracks are *Slave* to the *Master Track*. The *Master* and *Slave* tracks together are called *Master Track Group*.

Once the *Master Track Group* is defined, the *Play/Pause* and *Reset* commands (see below, §§ 5.1.2-5.1.3) will affect all the tracks, no matter which one is currently selected.

It is possible to detach a track from the *Master Track*: with this option, the *Play/Pause* and *Reset* commands performed within the *Master Track Group* will not affect this track, and vice versa. In case more than one track is detached from the master track, the *Play/Pause* and *Reset* commands will affect them all, whenever they are performed on one of these tracks.

To detach one or more tracks from the *Master Track*, select either the *Local* or *Instant* reset option in each track's *Reset On* menu item.

5.1.2 Play/Pause

In order to start or arrest your sequence, push the *Play/Pause* button (B.13). By default, this button works as a global control: if at least one track is playing, it pauses it; if all the tracks are playing, it pauses all of them; if all the tracks are paused, it plays all of them.

It is possible to play or pause only the selected track by holding *Esc* (B.4) before pushing the *Play/Pause* button.

Additional operations can be performed by combining the *Play/Pause* button with the *Set All* (B.1) and *Shift All* (B.2) buttons.

If the selected track belongs to the *Master Track Group*, pushing *Play/Pause* while holding *Shift All* will play or pause all the tracks of the group. In the case at least one track is paused, this combo will pause all the other ones within the group.

Hold *Set All* to set all the tracks of the *Master Track Group* like the one currently selected: if it is paused, all the related tracks will pause; if it is playing, all the related tracks will play. Each modification will happen after the current *Master Track* stage has ended.

If the selected track does not belong to the *Master Track Group*, pushing *Play/Pause* while holding *Shift All* will play or pause all the tracks which are unlocked from the *Master Track*. In case at least one track is paused, this combo will pause all the other ones outside the *Master Track Group*. Hold *Set All* to set all the non-*Master* tracks like the one currently selected, as described above for the *Master Track* group. Each modification will happen according to the reset setting of the track currently selected: if *Local*, it will happen after the current stage of the selected track has ended; if *Instant*, it will happen instantaneously.

The *Play/Pause LED* (C.1) will display the current state of the selected track: red if paused, and green if playing.

5.1.3 Reset

The *Reset* button (B.12) restores the playhead at the beginning of a pattern, i.e., at stage 1. It is possible to set whether the playhead returns to the first stage of the current pattern (*Reset Stage*) or to the first stage of the first pattern (*Reset Stage&Pattern*). To change this parameter, enter the *Track Menu* (see above, § 3.2), scroll until the **Reset What** option, and select either **Stage** or **Stage&Pa**. It is also possible to select the option **Nothing**, thus disabling the *Reset* button.

Each track can respond to the *Reset* command in four different ways. The first two depend on the track's relationship with the *Master* track:

- If the selected track is the *Master* track, the *Reset* button will reset it once the current stage has ended;
- if the selected track is a *Slave* track, the *Reset* button will reset it once the current stage of the *Master* track has ended: both these options are achieved by entering the *Track Menu*, scrolling to the **Reset On** option, and setting it on **Master**. This option is useful if you need to force several tracks to reset at the same time (for instance, if you are playing with different tempos or ratios).

If you want to reset a track independently, you have two more settings of the **Reset On** option, called **Local** and **Instant**:

- **Local** resets the selected track once its current stage has ended, without resetting any of the *Master/Slave* tracks;
- **Instant** resets the current track instantly, without waiting for it to end the current stage.

The *Reset* function can be executed through external triggers, see below § 7.2.

When *Pattern Shift* is enabled for a track (see below, §), the *Reset* button will set the sequence back to the first pattern plus the pattern shift number determined by the *CV offset*.

5.2 STAGE LOOP

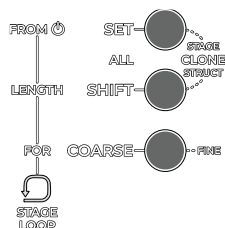

Figure 71: The *Stage Loop* section and controls (on the left).

In addition to the options above, USTA gives the chance to loop a specific portion of your pattern structure independently for each track through the *Stage Loop* option. Such a loop is nested within the main play mode and can work across different patterns. The looping function works only in *Pattern Mode*, and it interacts both with *Full*

Pattern Recall and *Pattern Mix* (see below, § 5.4). Once *Song Mode* is activated, the *Stage Loop* function will be automatically disabled.

Three variables are used to control the loop behavior: **FROM**, or the stage/pattern from where the loop starts; **LEN** (*Length*), how many stages are involved in this loop, and **FOR**, how many times it loops. These variables are shown in the bottom line of the *Dashboard* (F.17, F.18, F.19).

To define the *Stage Loop FROM*, hold the *Set All* button (B.1) and rotate the navigation encoder. The first number is the stage number, and the second one is the pattern number.

To define the *Stage Loop LENGTH*, hold the **Shift All** button and rotate the navigation encoder – length is expressed stages, so the resulting length depends on each stage length. Values go from 1 to 16.

To define the *Stage Loop FOR*, hold the **Coarse** button and rotate the navigation encoder – the **FOR** parameter express how many times these stages are looped until exiting this loop. Values go from 0 to 16 where 0 is no loop at all.

The only anchor point of the *Stage Loop* is the **FROM** parameter: it does not have a specific endpoint, but it is instead defined by a length which is expressed in number of stages.

To enable or disable the *Stage Loop*, double click the *Set All* button (B.1). When *Stage Loop* is active, the *Stage Loop LED* (C.6) will light up: if the playhead has not yet reached the *Stage Loop Section*, it will be red; if the playhead is already within the loop section, it will be green.



		
Stage Loop is disabled for the selected track	Stage Loop is enabled for the selected track, but the playhead is not yet in the loop	Stage Loop is enabled for the selected track, and it is in the loop

Table 12: *Stage Loop* LEDs comparison.

When *Stage Loop* is active, USTA will start the loop section once the playhead reaches the *From* point, it will play the stages within the *Stage Loop* for the defined number of times, then it will continue with the original sequence.

A small example with the following settings: **FROM** 02/03, **LENGTH** 04, **FOR** 02. This means that on *Pattern 3* it will play the following stages: 1 2 3 4 5 [2 3 4 5 2 3 4 5] 6 7... The stages between square brackets are the *Stage Loop*.

5.2.1 Infinite Stage Loop

If you set the **FOR** value to 0, the *Stage Loop* will loop endlessly once engaged: in this way, its duration is completely up to you. To make the playhead “exit” the *Infinite Stage Loop*, double-click the *Set All* button (B.1) to disable the *Stage Loop*.



5.3 SONG MODE

The *Song Mode* allows you to arrange your track's patterns in a custom sequence. It is an alternative mode of playing besides the default *Pattern Mode*: this means that *Song* and *Pattern Mode* cannot be active at the same time, but an option in the Track Menu lets you choose which one USTA will follow during the playback.

The *Song Mode* is a series of patterns that are assigned to *Slots*. A song can host up to 4 *Pages* of 16 *Slots* each for a total of 64 *Slots*. One song per track is available.

Once at least two patterns are composed in one track, the song mode allows you to arrange them in the desired order by fitting each of them into one or more slots. Each slot can be repeated up to 16 times before moving to the following one.

Bear in mind that the song is not a structural part of the track but an alternative arrangement of items, therefore, it cannot be cloned.

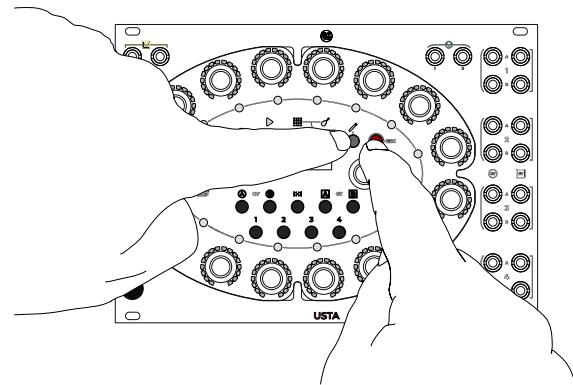

Figure 72: Edit Song combination.

You can create a *Song* while USTA is still playing in *Pattern Mode*. To do so, enter *Edit* mode (if you are not there yet) by pushing the *Pencil* button (B.5), and then enter *Edit Song Mode* by holding *Esc* (B.4) and pushing the *Pencil Button* again.

Now the guitar-shaped *Song LED* (C.3) will light up red, and the *Pattern LED* (C.2) will be green: this means that you are editing the song, while still being in *Pattern mode*.

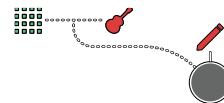

Figure 73: Editing a song while in *Pattern Mode*.

In this configuration, each of the 16 *Stage Encoders* (A.1) edits a slot of the selected page by performing two operations: selecting the pattern to be played in the desired slot and selecting the number of times that such pattern must be played (0 to 16). To change *Page* simply rotate the navigation encoder.

Once entering the Edit Song mode, all the five Parameter LEDs will turn red: this means that now USTA is editing the pattern number per slot.



Figure 74: The LEDs when editing the pattern number per slot.

Rotate each encoder to select the pattern to be played, numbered 1 to 32: the *Stage Arc* (A.2) will display the selected pattern number.

To edit the number of times that a pattern should be repeated per slot, push any of the Layer buttons to access the repetition parameter: the Layer RGB LEDs will all light up green.



Figure 75: The LEDs when editing the repetition number per slot.

In this mode, each encoder sets the number of repetitions, from 0 to 16, and the *Stage Arc* will light up accordingly.

To switch from *Pattern* to *Song* mode, enter the *Track Menu*, scroll to the *Play Mode* option, and change the setting from *Pattern* to *Song*. Exit the menu, and you will notice a different layout of the LEDs:

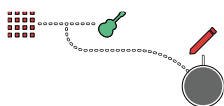

Figure 76: Editing a song while in *Song Mode*.

This will indicate that the selected track is currently in *Edit Mode* (red pencil LED – B.5), it is in *Song Mode* (green guitar LED – C.3), and you are seeing/editing the patterns (red pattern LED – C.2).

Once your song structure is set, push the *Play/Pause* button (B.13) to start the playback: while playing, the playhead will display and behave differently depending on the mode selected.

If the track is in *Edit Song Mode*, the stage LED:

- will be blue when that slot has a repetition bigger than zero,
- will be red only on the current playing slot
- will be cyan on the stages that are playing on that pattern. In the example below slots 1, 2, 3, 4, 7, 8, (maybe 9), and 16 have at least one repetition, the song is playing the 3rd slot, and in that pattern, the 9th stage is playing;

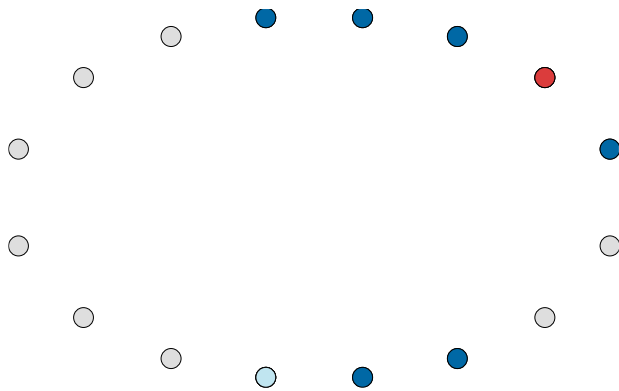

Figure 77: Stage LEDs in *Edit Song*. Note the playhead on Stage 9.

If the track is in *Edit Pattern Mode*, the playhead will follow the rules of this mode as described above (see *Editing, Playing, and Looping Patterns*, § 3.3): it will be visible only when USTA plays the pattern that is currently being edited.

If USTA is in *Performance Pattern Mode*, the playhead will move through all the steps of all the patterns following the structure determined by the *Song*.

When the *Song Mode* is enabled, the *Pattern Loop* indicators on the dashboard will be replaced by REP followed by two numbers: these stand for ‘repetition’ and display the current repetition of the pattern/the total number of repetitions set for that slot.

5.3.1 Pattern to Song While Playing (and vice versa)

It is possible to play in pattern or song mode, but it is also possible to change mode while playing without stopping the track or losing its sync: in the *Track Menu*, change the *Play Mode* option, and at the end of the pattern the selected mode will come into play.



Get an overview of the *Song Mode* with this Technique: [Song Mode](#)

5.4 LIVE PERFORMANCE TOOLS: PATTERN RECALL

When USTA is in *Performance* mode, either in *Pattern* or *Song* mode, every editing option is disabled: the 16 *Stage Encoders* (A.1) are now associated with the first 16 patterns, and while holding the *Shift All* button (B.2) they are associated with the last 16 patterns (or from the 17th to 32nd).

They work only as buttons, by pushing which it is possible to recall any of the patterns on the fly, thus temporarily bypassing the sequence of patterns you are expecting from the *Pattern Loop* rules or *Song Mode* set above. Once the selected pattern has been recalled and played, USTA will get back to the original sequence, with

different outcomes according to the play mode in use and the pattern loop selected.

USTA will memorize only one value: it means that if you push two encoders during this mode, only the latter will be effective.

Furthermore, there are two options: *Full Pattern Recall*, which is the default one, or *Pattern Mix*, available by holding down *Coarse* (B.3) before pushing the pattern encoder.

These recall options affect the selected track only.

With firmware version 155 we introduced the Voltage-Controlled Pattern Recall, on which see § 7.3.8).

5.4.1 Full pattern recall

With the *Full Pattern Recall*, USTA will wait until the active pattern has reached its end, then it will play the one selected by pushing its *Stage Encoder* (A.1).

If the selected pattern is *within* the *Pattern Loop*, USTA will continue to play the patterns after the selected one. (For example, if the *Pattern Loop* lasts from pattern 1 to 10, and you recall pattern 6 while being in pattern 2, the sequence would be: 2, 6, 7...).

If the selected pattern is *outside* the *Pattern Loop*, USTA will play it once, then continue after the previous pattern. (In the same example as above, if you recall pattern 15, the sequence would be: 2, 15, 3, 4...)

5.4.2 Pattern Mix

The *Pattern Mix* function is similar to the Full Pattern Recall, the main difference being when the pattern change happens. It is achieved by holding *Coarse* (B.3) before selecting the pattern through the *Stage Encoders* (A.1—Remember to hold *Shift All* to select patterns no. 17-32). Once the new pattern is selected by pushing the encoder, the playhead will wait for the playing stage to end and play the consecutive stage on the selected pattern, instead of the current one. For example, if you are playing stage 7 of the second pattern and select the fifth pattern, USTA will wait until the end of stage 7, then move to stage 8 of pattern 5, mixing them.

If the selected pattern does not have enough stages to maintain the sequence length of the current pattern, or if it is selected during the last stage of the current pattern, USTA will play the selected pattern starting with its first available stage.

To sum up, *Full Pattern Recall* juxtaposes patterns, while *Mix* combines them.



Practice the difference between these two functions with this Technique: [Pattern Recall and Pattern Mix](#)

5.5 MUTE

One of the most popular features of live performances is the *Mute* function, i.e., being able to immediately remove or add certain parts of the composition. USTA features two levels of muting: *Mute Track* and *Mute Channel*.

5.5.1 Mute Track

This function temporarily disables all the outputs of the muted track.

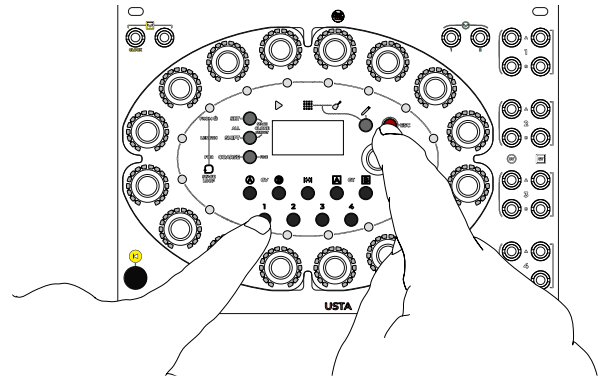

Figure 78: Mute Track button combination.

Muting a track causes it to have no Gate A and B output and no *CV A* and *B* output (all 4 outputs of the muted track provide a constant 0 V). To achieve this function, hold the *Esc* button (B.4) and push the button of the track you want to mute (B.11 see Figure 78). It is possible to mute any desired track, even if it is not the currently selected one.

A muted track shows the TRACK MUTED text on the current stage section of the *Dashboard* when selected.

5.5.2 Mute Channel

On a more specific level, the *Mute Channel* function allows muting solely the output of one or more channels per each track (*CV A*, *CV B*, *Gate A*, *Gate B*). This option may be useful in case you are using different channels of the same track to control different sound sources, such as *Gate A* for the kick drum and *Gate B* for the snare.

To mute a channel, hold the *Esc* button (B.4) and push any *Channel Button* (B.6, B.7, B.9, B.10).

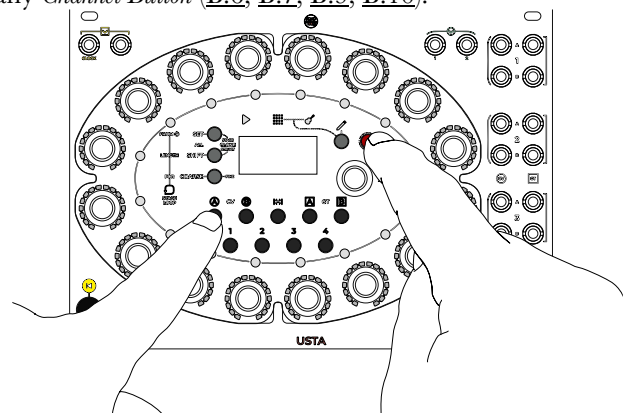

Figure 79: Mute Channel button combination.

5.6 HOLD

It is also possible to “freeze” the current channel value in a specific track through the *Hold* function: by holding *Set All* (B.1) and pushing one of the *Channel Buttons* (B.6, B.7, B.9, B.10), USTA will hold the values as they are playing in that specific moment until the buttons are released, see Figure 80.

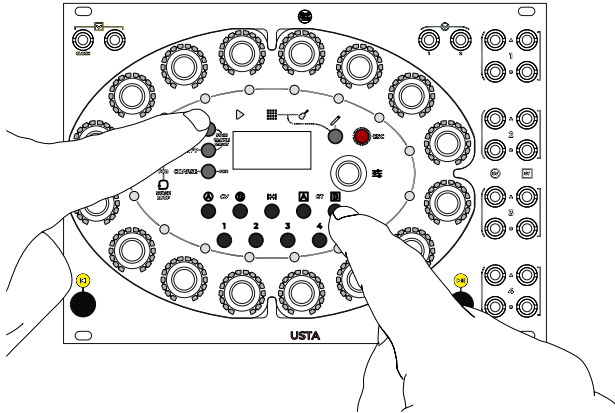

Figure 80: Hold button combination.

If the selected channel is *CV A* or *CV B*, USTA will hold the given value (i.e., it will not calculate other stages' values); if the selected channel is *Gate A* or *Gate B*, USTA will perform a sort of legato (if the gate is high when the channel button is pushed) or mute (if the gate is low).

After releasing the buttons, the sequence will return to playing from the position reached by the playhead in the meantime.



Practice the Hold mode with this *Technique*:
[USTA Hold](#)

in a different pattern than the selected one, the first stage of the selected pattern will become cyan and open its gate.

Rotate the *Navigation Encoder* (B.14) back and forth to move the playhead across the different stages: this will allow you to manually “scan” through the sequence to check and edit the current stage settings. This parameter will work in both directions just like an analog reel-to-reel recorder, and it will work through different patterns: once the 16th stage is reached, further clockwise rotation of the *Navigation Encoder* will move the playhead to the first stage of the following pattern, while rotating counterclockwise past the first stage of a pattern different than the first move the playhead to the last stage of the previous pattern.

The display will automatically update the stage data (*CV A*, *CV B*, *Gate A*, *Gate B*, and *Length*) according to the selected stage.

Once you have finished your editing operations, double-click again the selected track: USTA will get back to the original sequence and it will play it starting from the last played stage (i.e., before entering the *Composition Mode*). In case you want to hear your sequence from the beginning, simply push the *Reset* button (B.12).

If you push the *Play/Pause* button (B.13) while still in *Composition Mode*, the sequence will play after the one currently selected. This feature can be very useful in case you want to hear portions of your sequence starting in other stages than the first one.

Composition Mode is not available when the *Track Menu* is open, and it ignores Green or Red CV/Gate stage colors, being Gate on that track always high and CV always reproducing exactly the selected stage value.



Practice this mode with the following *Technique*:
[Composition Mode](#)

6 ADVANCED EDITING

6.1 COMPOSITION MODE

If you prefer to compose when USTA is not playing, e.g., if you must handle longer polyphonic sequences, crossing several patterns on multiple tracks, USTA provides a system for asynchronous voltage monitoring called *Composition Mode*.

When USTA is in *Edit Pattern Mode* and paused (red *Play/Pause LED* – C.1), select the CV layer you want to edit and double-click the desired track button: this will set *Gate A* and *Gate B* high, and the cyan playhead will light up on the last played stage. In case the last played stage is

6.2 USE AN EXTERNAL CV/GATE KEYBOARD

To compose your sequence with an external keyboard (or any other 1V/oct controller), you need the current track to be stopped (red *Play/Pause LED* – C.1) and in *Composition Mode*.

Connect the keyboard gate output to the *Auxiliary Gate* input (D.2) and the keyboard CV output to the *CV A* input (D.3). From now on, pushing a key on the keyboard will overwrite the defined note (*CV A*) of the stage highlighted in composition mode, and the keyboard gate output coming from the key release will move the playhead to the following stage.

This method inputs only the pitch values, regardless of the stage length: to set the rhythm, refer to the section about setting the *Length*, see above § 3.4.1).

Bear in mind that when composition mode is enabled, the main function of the *Auxiliary Gate* input is bypassed to allow the use of the external keyboard composition mode.



Practice this feature with this *Technique*:
[Keyboard Input](#)

6.3 STORE PATTERN: LAST PLAYED OR LAST FULL

Should you prefer a less deterministic compositional approach, e.g., by progressively adding some degree of variation through the green and blue layers, while your sequence is playing, or adding external modulations via CV, until you find the perfect combination, USTA stores the last played values of a pattern, allowing you to recall and reproduce them.

Every time USTA plays a stage, its values are stored in volatile memory until the playhead crosses it again, overwriting it. This leads to a constantly updating 16-element array, one per stage, per each track, which can be transferred anytime over the desired pattern.

The data stored per last played stage are the values for all the *Channels* (*CV A*, *CV B*, *Gate A*, *Gate B*) as well as the *Length*: no data about *Variation Index*, *Range*, or *Stage Colors* are stored.

There are two store modes, *Last Full Pattern*, and *Last Played*. The difference between the two is that the former updates the full array at the end of the pattern, while the latter updates the array every time a new stage is played while removing the oldest array element.

To access the stored values, select the track ([B.11](#)) whose stages you want to copy through the layer buttons, make sure you are in *Edit Mode* (*Pencil* button and LED, [B.5](#)) select the target pattern by rotating the *Navigation Encoder* ([B.14](#) – you can also leave the current pattern and overwrite its values while playing), then push the *Shift All* button twice ([B.2](#)) for the last full pattern, or the *Coarse* button twice ([B.3](#)) for the last 16 played stages: the result is now dumped in the desired pattern.

These actions work also when USTA is stopped, in case you want to dump multiple layer values or make more “copies” of a pattern. Every value is linked to its respective stage and will be dumped only on it.

All the values are set to 0 at startup. If you overwrite the current pattern, all the previous data concerning *Variation* (green and blue layers) will not be affected, so the resulting sequence might differ from the one you copied due to the *Variation* still being performed by USTA: if you want to hear the last played sequence, simply set all the *Variation Index* and the *Variation Range* to 0. The same approach is applied to possible CV modulations in use. If you perform the dump halfway through a pattern, which has, for example, stages 8-16 with length 0, or if the store is performed straight after the start-up, the dumped value of the non-played stages will be 0.

6.4 ROTATE PATTERN

It may happen that when improvising with various degrees of unpredictability, you end up with the perfect sequence, only to find out that it is one or two stages off-beat. To overcome this issue, USTA allows you to *Rotate* a pattern and align it to the other tracks, so that the beginning of your newly found sequence is exactly where it is supposed to be.

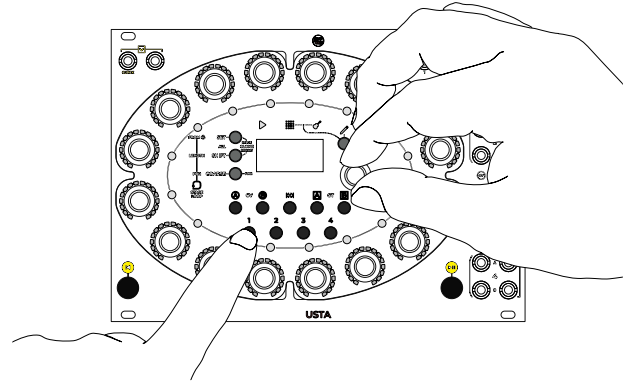

Figure 81: *Rotate Pattern* button combination.

To *Rotate* a pattern, push and hold the *Track* button ([B.11](#)) and rotate the *Navigation Encoder* ([B.14](#)) either clockwise or counter-clockwise: you will see the 16 stages rotate accordingly, and, if your sequence is running, you will hear it changing immediately (see Figure 81).

This function shifts the *Length*, *Channels*, and *Layers* of a pattern at the same time (all the stage values, with their *Variation Index* and *Range*).

6.5 CLONING

To speed up the editing process, it is possible to copy and paste the stage data (CV A, CV B, gate A, gate B, length). This operation is called *cloning*, and you can perform it at a stage level or by copying stage data in bulk (layers, patterns, or even tracks).

Keep in mind that all clone functions are destructive editing and are similar to editing the stage with their encoders.

6.5.1 Clone a Stage

It is possible to clone all the data of a specific stage onto another of the same pattern. By doing so, all the layers of the target stage (see above the section concerning editing stages, § [3.4](#)) will be replaced with the data contained in the source.

To do so, hold the *Esc* button ([B.4](#)) and push *Set All* ([B.1](#)), then release both buttons.

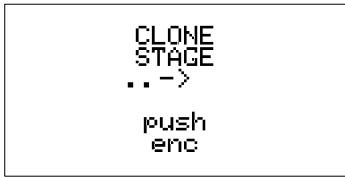

Figure 82: Cloning a stage.

The *Clone Stage* menu will appear in the OLED display (C.5). First, enter the stage to clone: push the corresponding stage encoder (A.1, no. 12 in the example): its number will appear within the display.

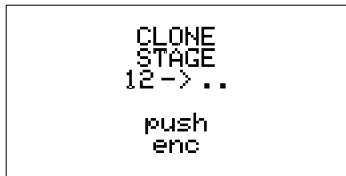

Figure 83: Cloning stage 12.

From now on, push any other *Stage Encoder* to clone the data of the source stage. This last operation can be repeated as many times, to clone a single stage towards multiple destinations.

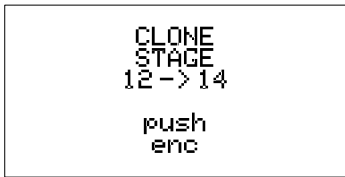

Figure 84: Cloning stage 12 to 14

The last cloned target will be updated on the display, as above (14 in the example).

At any moment push *Esc* to exit the *Clone Stage* function.

6.5.2 Clone a Structure

It is also possible to clone structures (STRUCT) of stages: these are in fact *Layers*, *Patterns*, and *Tracks*. Layers and patterns may be cloned within their track only.

To clone any of these *structures*, hold the *Esc* button (B.4) and push *Shift All* (B.2), then release them.

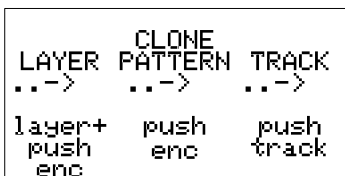

Figure 85: Clone Structure selection.

The *Clone Struct* menu will appear in the display, proposing all structures that can be cloned. At any moment simply push *Esc* to exit the *Clone Struct* function.

6.5.2.1 Clone a Layer

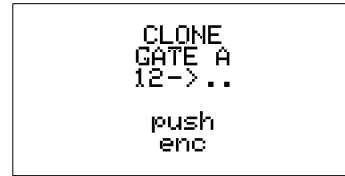

Figure 86: Cloning Stage 12's Gate A value.

To clone a *Layer* (*CV A*, *CV B*, *Length*, *Gate A*, *Gate B*) of a pattern, push and hold the button for the layer you want to clone (B.6-B.10), then push the *Stage Encoder* (A.1) to define the source pattern (encoder 1 for pattern 1, encoder 2 for pattern 2 and so on). To access patterns from 17 to 32, push and hold also the *Shift All* button (B.2).

From now on, push any other *Stage Encoder* to clone the selected layer of the source pattern to the desired target (the example shows cloning of *Gate A* data of pattern 12 of the selected track). Press other pattern encoders to repeat the cloning to multiple targets without restarting the procedure.

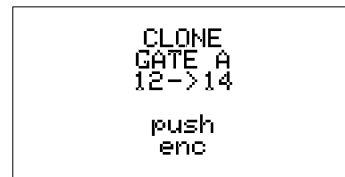

Figure 87: Cloning Stage 12's Gate A value to Stage 14.

The last cloned target will be updated on the display as above (14 in the example).

6.5.2.2 Layer Cross-Cloning

It is also possible to clone a layer to a different CV or Gate channel than the original one, for example, cloning the *CV A* Value of Pattern 1 to *CV B* of Pattern 3, or the *Gate B* Variation Index of Pattern 15 to *Gate A* of Pattern 22.

To do so, follow the same procedure as for cloning a layer, but hold the target CV or Gate button (B.6, B.7, B.9, B.10) before pushing the target Pattern encoder.

6.5.2.3 Clone a Pattern

To clone a *Pattern*, when the *Clone Struct* menu is displayed, push the *Stage Encoder* (A.1) for the source pattern (encoder 1 for pattern 1, encoder 2 for pattern 2, and so on). For patterns from 17 to 32, first hold down the *Shift All* button (B.2).

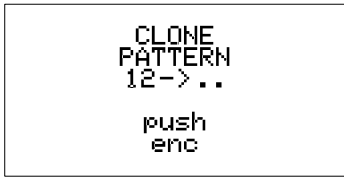

Figure 88: Cloning Pattern 12.

From now on, push any other *Encoder* to clone the data of the source pattern to the desired target (the example shows cloning pattern 12 of the selected track). Push additional pattern encoders to clone to multiple targets without restarting the procedure.

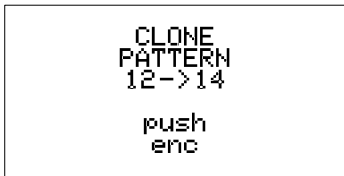

Figure 89: Cloning Pattern 12 to Pattern 14.

The last cloned target will be updated on the display as above (14 in the example).

6.5.2.4 Clone a Track

To clone a *Track*, when the *Clone Struct* menu is displayed, select the source track by pushing its corresponding *Track Button* (B.11).



Figure 90: Cloning Track 1.

From now on, push any track to clone the data of the source track to any target track you want (the example shows the cloning of track 1).

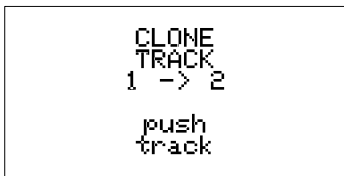

Figure 91: Cloning Track 1 to Track 2.

Press additional track buttons clone to multiple targets without restarting the procedure.

The last cloned target will be updated on the display as above (2 in the example).

Remember that when cloning a track you are still cloning the stage data, namely CV A, CV B, gate A, gate B, and length, **not** the track settings in the Track Menu. To apply the same settings to more tracks, use the Set All button before setting the menu options.

6.6 QUICK TRACK INITIALIZATION

Composition is a process that involves a certain amount of trial and error. In case you are not satisfied with what you came up with, you can always erase the content of a track, without having to manually do it, or worse, start a new project from scratch.

To initialize a track, select it (B.11), make sure to be in *Edit Pattern* mode (see above, § 3.3), and then push and hold the *Pencil* button for three seconds (B.5).

This procedure will restore the selected track to its original state, without affecting the other three.

6.7 QUICK SONG INITIALIZATION

On the same line, it is also possible to initialize a *Song*, in case you want to quickly arrange your patterns in a new order.

To do so, select a track, then enter *Edit Song* mode (see § 5.3); from here, push and hold the *Pencil* button for three seconds (B.5), and you will restore all the song *Slot* values to 0.

7 EXTERNAL CONTROLS

Four jack sockets on the top of USTA's front panel are dedicated to external modulation: two are designed to receive external trigger or gates, and two are for external CVs.

The external gate sockets are used for an external *Clock Input* (D.1) and *Play/Pause* or *reset* (the *Auxiliary Gate*, D.2); the CV inputs (D.3 and D.4) can be individually routed to four different modulations per track, called *Varishift*, *Stage Shift*, *Gate Shift*, *Root Shift*, and *Pitch Shift*. These four modulations are called *Shifts* because they all increase (or decrease) a stage's set value according to the incoming voltage. Please note that all these modulations are applied by USTA after a stage has ended, except *Pitch Shift*, which is the only one that can happen in real-time, i.e., during a stage.

7.1 CLOCK INPUT

To use an external clock source, connect it to the *Clock Input* (D.1) and select **External** from the **ClockSource** option in the *Track Menu* (see above, § 3.2.1). USTA will now operate just as with its internal clock, with some minor considerations.

When an external clock is in use, the options of *Swing* (see below, § 8.4) and *Ratio* (see above, § 3.2.1) are always

available: however, since they are calculated by USTA for each new stage over a median value of the previous impulses, the quality of the effect depends on a steady external clock.

In case Swing and ratios different than 1:1 are not needed, it is possible to use random or even manual triggers to animate the sequence.

7.2 AUXILIARY TRIGGER/GATE INPUT

USTA offers an additional input for external gates (D.2), whose effects can be chosen according to internal routing parameters.

By default, it resets the sequence, but it can also be used to receive *Run* signals to sync USTA with other hardware. This setting is global and can be accessed through the *Project Menu* (§ 3.1), under the item *Aux Target*.

7.2.1 Reset

When the *Aux Target* is set to *Reset*, the gate patched to the AUX input performs the same function as the manual *Reset* button (B.12), affecting the tracks according to the *Reset What* (*Stage* or *Pattern*) and *Reset On* settings (*Master*, *Local* or *Instant* – see above, § 5.1). A gate high signal equals pushing the *Reset* button, and a gate low signal equals releasing it.

7.2.2 Run

Any of the four *Run* options of the *Aux Target* menu is designed to control USTA with other devices while using an external clock.

The gate signal patched to the *Auxiliary* input (D.2) now has three functions: play, stop, and reset. Since different devices have different sync behaviors, USTA allows for three different options, as described in the table below:

	Gate High	Gate Low
Run 1	Reset, then stop	Play
Run 2	Play	Reset, then stop
Run 3	Stop, then reset	Play
Run 4	Play	Stop, then reset

Table 13: Run modes.



Practice the reset input with this *Technique*: [One-Shot Sequence](#)

7.3 EXTERNAL CV

USTA has two inputs that welcome CV for modulation purposes. The destination of the modulation is routed through specific menu settings. One input can be assigned to multiple modulation options.

To enable the external CV modulation for a given track, enter the *Track Menu*, and scroll to the *Shift* section. The options available are *PitchShiftA*, *PitchShiftB*, *Root Shift*, *Gate ShiftA*, *Gate ShiftB*, *Stage Shift*, *Vari Shift*, *Phase Shift*, and *Pattern Shift*. Choose the selected destination, push the encoder, and select the source among *None*, *Ext CV A*, and *Ext CV B*.

7.3.1 Pitch Shift

Pitch Shift can be performed with CV layers in *Pitch* mode.

In this mode, the input is continuously sampled and rounded to the smallest interval available in the quantization scale selected (by default it is a semitone, but it can be changed, see below § 9.1). Each time the quantized value changes, the modulated track will shift its pitch accordingly, even while the stage is playing.

If the *Variation* layers (*Index* and *Rang*) are used to modify a stage value, this will be considered by USTA at the beginning of the stage, before the *Pitch Shift*, and such variation will not be performed again during the stage, even when the external *Pitch Shift* changes value.

The resulting value is then quantized in reference to the *Scale*, *Root*, and *Quantization Direction* in use (§ 9.1).

Example: in C major, a stage with *Variation Range* value 2 (so ± 4 semitones) has a normal note *Value* of D. The *Variation Range* coin toss specifies +2 semitones, resulting in a note value of E. If the pitch shifting is 0 at the beginning of the stage, USTA will play an E. If the CV modulates mid-stage from 0 V to 0.5 V (+6 semitones), the resulting *Pitch Shift* would change the E +6 semitones to A#, which would then be quantized, according to the *quantization direction* preferences, to B or A.

It is not possible to perform *Pitch Shift* when using *Raw CV* mode: it would make more sense to sum non-quantized voltages outside USTA, using, for instance, a 333 module.

Pitch modulation “à la” mod wheel is suggested to be performed with a 333 as well, to avoid the stepped effect of the dynamic quantization.

7.3.2 Root Shift

This CV destination lets you modify the root of the *scale/mode* selected for the *Dynamic Quantization* (see below § 9.1). If, for instance, the selected mode is *Locrian*, any incoming CV will change the root and create other *Locrian* modes to which quantize the ongoing melody. It can be very useful to create modal pieces with CV automation: if the same CV is routed both to the *Root Shift* and the *Pitch Shift*, the result will be an exact transposition.

It goes without saying that if the selected scale is chromatic the *Root Shift* will not produce any noticeable effect.

7.3.3 Gate Shift

This parameter uses the incoming external CV to increase or decrease the gate values played by USTA in a given stage. The lower and higher values will still be 0 and 16: this means that if the stage has a defined value of 0 gates (i.e., it counts as a musical pause), a negative offset will not produce any audible effect; the same happens if the stage has a defined value of 16 gates and it receives a positive offset.

It is possible to use this modulation to mute a given stage by providing a negative offset that will set the gate value to 0.

7.3.4 Stage Shift

This modulation shifts the stage values of the four channels of the track while retaining the original stage length defined by the sequence. In other words, while the playhead keeps the rhythmic structure, the melodic content is changed according to other stage values further down the pattern.

When *Stage Shift* is in effect, and any of the four channels are selected, the cyan playhead will display the target stage, i.e., the “shifted” one; when the *Length* parameter is selected, it will display the regular stage sequence.

An example: a pattern is set up with a stage length of 1 unit from stage 1 to 8, and stage length 0 from stage 9 to 16. The normal behavior when looping it is that the stages are played from the 1 to the 8 then back from the first and so on. The CVs and gates generated are the values set in their stages. With Stage Shift, the individual length of the stages is unaltered, but their CV and Gate values will be replaced with those of the target stages, determined by the incoming CV offset. In this case, if a steady offset of 2 is detected, the pattern will have the length of stages 1-8, but the values of stages 3-10.

The stage shift does not cross patterns, so whenever the result of the shifting is bigger than 16, the number is then folded back from stage 1.

The stage shift is calculated on the stage change: this makes it possible to obtain shifts, drunk modes, or any kind of strange stage sequence without affecting the rhythmic structure of your composition.

To enable the *Stage Shift* mode, select the desired track, enter its menu, and navigate until `StageShift`, selecting the CV channel you want to use as a source for that shifting. Either CV 1 or 2 can be used for this purpose.

7.3.5 Vari Shift (Variation Shift)

Another possible destination for external CV is the *Variation Range* for *CV A* and *CV B*, which is manually set by the blue layer. With this option, it is possible to automatically increase or reduce the spectrum of values which USTA can pick whenever the CV Variation chance parameter is higher than 0.

As described in *Blue Gate Layer* above, the *Variation Range* is bipolar: a positive CV will increase such range both above and below the stage value, and a negative CV will decrease it.

Please note that if the CV *Variation Chance* (green CV layer) is set to 0, this modulation will not produce any audible effect.

7.3.6 Pattern Shift

It has been said that the default order of patterns in Pattern Mode can be temporarily altered through Pattern Recall and Pattern Mix or defined in a different structure through Song Mode.

However, it is also possible to automatically recall other patterns through *Pattern Shift*. This function uses an external CV to change the pattern which would naturally follow the current one in the Pattern Loop: it does not recall, therefore, any pattern outside the defined *Pattern Loop*. For the same reason, the *Pattern Shift* is not designed to operate in *Song Mode*.

By default, in *Pattern Mode* USTA moves forward by 1 pattern at a time. *Pattern Shift* adds an offset to the default +1 operation: for example, if a fixed CV offset equivalent to 1 is applied, USTA will skip a pattern out of two (thus moving from 1 to 3 and from 3 to 5); if the pattern loop contains only three patterns, USTA will skip from pattern 1 to 3, then it will loop back to 2, then back again to 1, 3, 2 and so on. If a pattern loop contains four patterns, and an offset of 3 is applied, USTA will seem to keep looping only the pattern on which the Pattern Shift started, because the new offset will force the loop always back to it.

When Pattern Shift is enabled, the Reset button will behave accordingly: instead of resetting the loop to the First Pattern, it will reset to the pattern whose number is defined by the first pattern + the pattern shift offset.

7.3.7 Phase Shift

USTA allows you to use an external CV to shift the phase of a track, i.e., its position in relation to the expected timing: a positive voltage will shift a track up to half time unit “behind the beat”, thus allowing effects such as rubato or delays.

The great advantage of the *Phase Shift* is that even if it may seem to slow down the track, it does not affect the clock: when the incoming CV goes back to 0, or when the cable is unplugged, the track will immediately get back to the usual position in time.

Interesting effects can be obtained with manual offsets (like 321), envelopes (like FALISTRÌ), or clocked random voltages (like SAPÈL).

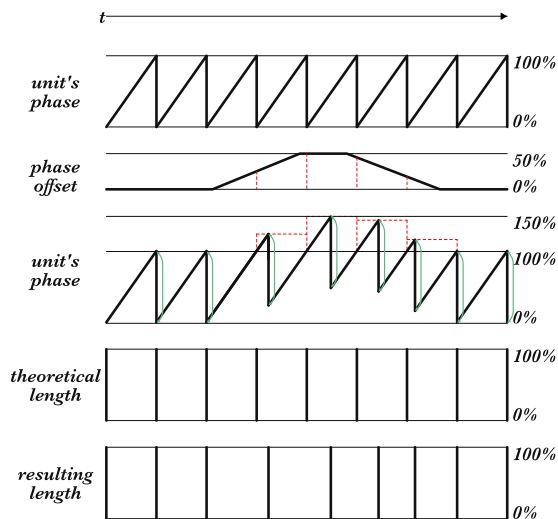

Figure 92: Visual representation of Phase Shift.

7.3.8 Voltage-Controlled Pattern Recall

The **Ptrn Recall** menu voice has been introduced with firmware 155 and it is the only one not built around the *shift* concept.

This option allows you to recall any pattern with an external CV. Once a pattern is voltage-recalled, USTA will loop it until the voltage is held.

Each of the 32 patterns corresponds to a discrete voltage value with increments of 0.25 V. So, for example, pattern 1 is 0 V, pattern 2 is 0.25 V, pattern 5 is 1 V, and so on until pattern 32, which corresponds to 8 V.

In the V/oct standard, these increments correspond to minor thirds, so the individual notes of a C diminished chord recall four patterns.

Every other value between these discrete voltages will be approximated to the closest one. Every value lower than 0 V will be approximated to 0 V, while every value higher than 8 V will be approximated to 8 V.

USTA processes the pattern-recalling voltage at the end of the currently playing pattern, so make sure to send the voltage a few milliseconds before the new one! For example, you cannot crosspatch a CV from another track, because it would reach the destination at the same moment of the pattern change.

If you send a CV when USTA is stopped, it will process its information after the current pattern.

When the Voltage-Controlled Pattern Recall is active, you can still use the Pattern Recall and Pattern Mix functions (see § 5.4)

The Voltage-Controlled Pattern Recall overrides the Pattern Loop settings. Even if it is still possible to change the first and last patterns, the setting will be ignored until the **Ptrn Recall** option is disabled again.

If you plan to use both the Pattern Loop and the Voltage-Controlled Pattern Recall, you can prepare a pattern with length 0 (all the stages off). Once recalled, USTA

will get back to the pattern loop even if the VCPR is active.



Practice some of the different CV modulations with these Techniques:

- [Pitch Shift](#)
- [Root Shift](#)
- [Phase Shift](#)
- [Pattern Shift](#)
- [Varishift](#)
- [Stage Shift](#)
- [Offset](#)
- [USTA as a Quantizer](#)
- [Phase Shift #2](#)
- [Stage Shift Probability #1](#)
- [Stage Shift Probability #2](#)
- [Stage Shift Probability #3](#)
- [Stage Shift & Gates](#)

8 ADDITIONAL OPERATIONS

In addition to the previous operations, USTA allows you to perform deeper editing options. According to their position in USTA's architecture, such options are located either in the *Project Menu* (§ 3.1) or in the *Track Menu* (§ 3.2).

8.1 SELECT CV MODE (RAW OR PITCH)

In each track, *CV A* and *CV B* can be set to work in *Pitch* or *Raw* mode, independently. These two modes have been created to fulfill any need depending on the addressing of that control voltage: if a control voltage for an oscillator's pitch is needed, or for anything that responds in V/oct, it is suggested to use pitch mode, while Raw mode is suggested for any other application.

By default, *CV A* is set to work in Pitch and *CV B* in Raw. To change that, select the track you want to modify, push the *Navigation Encoder* to access the *Track Menu* (B.14), and scroll to reach the *CV A Mode* or *CV B Mode* menu item: push again the navigation encoder, scroll to select the desired mode, push again to confirm and push *Esc* (B.4) to exit.

Remember that when *CV A* or *CV B* are set to work in Pitch mode, the dashboard will display the note; when they are set to work in raw mode, the dashboard will display the voltage on a milliVolt scale.

8.2 CV RANGE

USTA offers the option to set each CV output independently per track to work in a unipolar range (from 0 V to 10 V) or in a bipolar range (± 5 V). This setting is independent of the CV output being *Pitch* or *Raw*. The reason for this option is that sometimes it might be useful to have negative values for lower notes, such as if you want to tune your oscillators to 440Hz, but some other times it

might be useful to have the CV working only into positive values, such as to modify the filter cutoff. By default, every parameter is set to work in a unipolar range.

This setting is 100% software dependent, therefore different settings for each track's channel can be set, stored, and recalled for each project.

To set the range of a CV output of a track, push the *Navigation Encoder* to access the *Track Menu* (B.14) and scroll to reach *CV A Range* or *CV B Range*, then select the preferred *Range* (0/+10 V or -/+5 V). Push again to confirm and the *Esc* button (B.4) to exit.

If it is necessary to trim a specific CV output, see the section about output trimming.

8.3 GATE WIDTH %

By default, when the *Gate Color* is green (see above, § 3.4.5) the gate width (i.e., the time it stays high) is 50% of the time between two consecutive gate-rising edges. It is possible, however, to change this percentage independently for gates A and B for each track. In the *Track Menu* select *Gate A % Width* or *Gate B % Width* and choose the desired value: the selectable range spans from 10% to 90%.

8.4 SWING

USTA allows adding a swinging feel to each track independently through the *Swing* option.

Traditionally, the swing is a rhythmic style that implies an alteration of the standard eighth note pattern by playing the downbeat note longer than the upbeat one, thus providing a sort of “bouncing” feel. It is commonly played in blues and jazz styles, but it can be a useful tool to add some groove to an electronic composition too.

There is no fixed rule to determine the swing ratio, or the relationship between the first and the second element of a couple of eighth notes played with a swing feel. Generally speaking, the swing happens anywhere between 1:1 (no swing at all) and 3:1 (where the first note is a dotted eighth note and the second one a sixteenth note); the most common ratio is around 2:1, which sounds like a triplet

of eighth notes where the first one is a quarter note and the second one is an eighth note.

USTA implements *Swing* by delaying the second note in each pair. The delay amount is indicated in the percentage of note length. For instance, a swing setting of 50% means that the second note will be delayed by half of its length, making the first one 50% longer, which translates into a swing ratio of 3:1; a swing setting around 33% or 34% translates roughly into a swing ratio of 2:1 and so on. The maximum setting allowed by USTA is 75%, which provides an extreme ratio of 7:1 – this goes way beyond the conventional swing styles, and it can be used for more experimental rhythmic structures.

The *Swing* parameter operates between couples of *units* (see above, § 2.2). If two stages have a length of 1 unit each, the effect will be noticeable. If they have a length of 2, the swing theoretically happens within the stages, so it will not be audible. If they have a length of 3, the swing happens between the last unit of the first stage and the first unit of the second stage, and so on. In other words, the swing can be heard only if the length of at least one out of two stages has an odd number of units.

If the selected pattern has an even number of stages, the swing pattern will be repeated consistently across different loops; if the pattern has an odd number of stages, the last stage will be read by USTA as the first element of a pair of notes, whose second element will be the first note of the following pattern, or the same pattern if it is looping. This last scenario results in alternating rhythmic variations on the same pattern, because on the second loop, all the upbeats and downbeats will be flipped.

8.5 CURRENT STAGE DATA

In *Performance Mode*, either in *Pattern* or *Song*, the fifth row of the dashboard can be set to display in real-time the five channels (*CV A*, *CV B*, *Gate A*, *Gate B*) of the stage that is currently being played by the playhead, instead of the last edited stage.

To activate this option, enter the *Project Menu*, scroll until the *Show In Play* item, and select *Yes* (by default, this option is set to *No*, as it may slow down USTA).

9 PLAYING IN TUNE

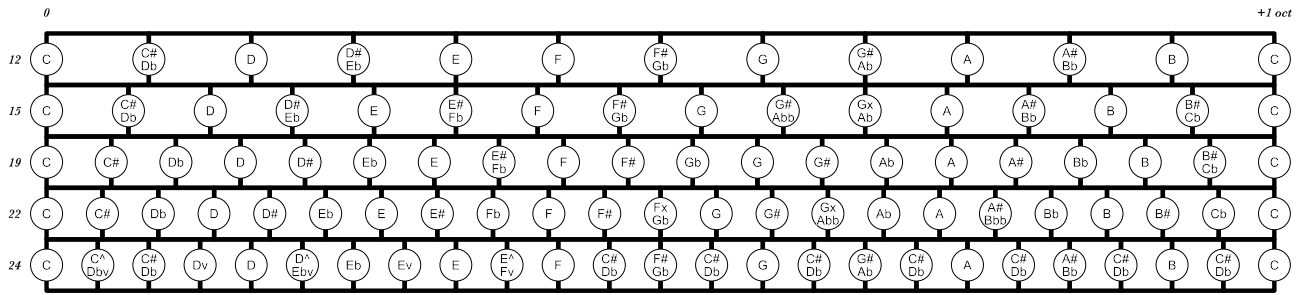

Figure 93: Visual representation of alternative octave divisions.

432		434		436		438		440		442		444		446	
C	A	C	A	C	A	C	A	C	A	C	A	C	A	C	A
32.11	27.00	32.26	27.13	32.41	27.25	32.55	27.38	32.70	27.5	32.85	27.63	33.00	27.75	33.15	27.88
64.22	54.00	64.51	54.25	64.81	54.50	65.11	54.75	65.41	55.00	65.70	55.25	66.00	55.50	66.30	55.75
128.43	108.00	129.03	108.50	129.62	109.00	130.22	109.50	130.81	110.00	131.41	110.50	132.00	111.00	132.60	111.50
256.87	216.00	258.06	217.00	259.25	218.00	260.44	219.00	261.63	220.00	262.81	221.00	264.00	222.00	265.19	223.00
513.74	432.00	516.12	434.00	518.49	436.00	520.87	438.00	523.25	440.00	525.63	442.00	528.00	444.00	530.39	446.00
1027.4	864.00	1032.2	868.00	1036.9	872.00	1041.7	876.00	1046.5	880.00	1051.2	884.00	1056.0	888.00	1060.7	892.00
7		3		9		5		0		6		0		7	
2054.9	1728.0	2064.4	1736.0	2073.9	1744.0	2083.4	1752.0	2093.0	1760.0	2102.5	1768.0	2112.0	1776.0	2121.5	1784.0
5	0	6	0	8	0	9	0	0	0	2	0	0	0	5	0

Table 14: C and A frequency chart for different tunings. The values are in Hz.

9.1 ROOT & SCALE – DYNAMIC QUANTIZATION

In *Pitch* mode, the scale selected, according to the *Root* note, defines how to quantize the outgoing semitones in 1V/oct reference. (In *Raw* mode, the selected scale and root note are ignored, and no quantization is performed.)

To select a *Root* for a track, press its track button, push the *Navigation Encoder* (B.14) once to access the *Track Menu*, and scroll up to reach the *Root* menu item: push the navigation encoder to view the root options, scroll to select the desired root note for your scale, and push again to confirm.

Next, scroll to select the *Scale* menu item: push the navigation encoder again to view the scale options, scroll to select the desired scale, and push the encoder once again to confirm.

It is also possible to choose one of four *Quantization Directions*, used to determine the quantized values for input voltages, first within the selected base scale (e.g., 12EDO), then within the specific scale version (e.g., Major Pentatonic 1):

Near Up – finds the nearest match in the selected base scale, starting from the first higher, then checks the first lower, then the second higher, then the second lower, and so on until the first match for the selected scale version is found.

Near Down – finds the nearest match in the selected base scale, starting from the first lower, then checks the first higher, then the second lower, then the second higher, and so on until the first match is found.

Up – finds the nearest match in the selected base scale, always increasing the pitch, so all lower semitones are

ignored. It checks then the first higher, then the second, then the third, and so on until a match for the selected scale version is found.

Down – finds the nearest match in the selected base scale, always decreasing the pitch, so all higher semitones are ignored. It checks the first lower, then the second, then the third, and so on until a match for the selected scale version is found.

To do that, scroll to select the *Quant Dir* menu item: push the navigation encoder to view the options, scroll to select the desired quantization direction for your scale, and push again to confirm. All the generated notes will be quantized following these four rules.

Another useful feature is that when the *Variation Range* is active for a stage, the result of the variation is routed to the quantizer, to output a note that consistently matches the selected quantization settings. See the *Scales* section below (§ 12) for a table of the available scales.



Practice the *Dynamic Quantization* settings with this Technique: [Quantization](#)

9.2 MICROTONALITIES

The fact that equal temperament is the most common in Western music does not mean that it should be the only harmonic framework for your compositions.

For more experimental composers, USTA allows choosing octave divisions for microtonal music different from the standardized 12-EDO (Equal Division of

Octave). Four of them are available: 15-EDO, 19-EDO, 22-EDO, and 24-EDO.

To select an alternate octave division, open the Track Menu and scroll until the `TonesPerOct` item. The default option is `12EDO`, which is the standard Western equal temperament. When `12EDO` is selected, the *Scale* and *Root* options (described in the *Scale&Root* section, above) determine the quantization.

When another option is selected, scale and root are obtained from the menu items below, according to the number of tones per octave desired. For example, when `TonesPerOct` is set to `19EDO`, scale and root are determined by the options set in `Root 19` and `Scale 19`, respectively: `Root 15`, `Scale 15`, `Root 19`, `Scale 19`, `Root 22`, `Scale 22`, `Root 24`, `Scale 24`.

A wide variety of preset scales is available, but it is also possible for the user to define up to four custom scales per each octave division. The settings specified for the *Quantization Direction* will apply to every octave division selected.

Whenever an octave division higher than 12 is selected, the visual feedback system of the *Stage Arc* (A.2) will change accordingly. After the encoder has reached the 11th tone, and the 11th LED of the Stage Arc has lit up, the following intervals will be displayed by the leftmost LEDs turning off, until the last one (15th, 19th, 22nd, or 24th) is reached; then, the following octave will begin from scratch with another LED lighting up on the rightmost side.

When the Coarse button is held down, the encoder will always shift the stage value by 1 octave per click; holding the *Fine* button will always shift the pitch by cents.

Please note that higher EDOs will result in a smaller octave range because the total number of notes that can be performed by USTA stays the same. (For example, if a 24EDO is selected, USTA's range will be 5 octaves instead of 10).

External pitch shifting is still available, even if the 1V/oct standard is no longer in use. In these microtonal modes, 1/12v corresponds to a single interval, no matter the octave division: in other words, if a standard V/Oct keyboard is used to perform Pitch Shift, a semitone above will shift the melody of 1 microtonal interval. If the 24 EDO is selected, two octaves on a keyboard will correspond to one octave on USTA.

This 1/12 V-per-interval is available also in Composition Mode via an external controller: each key of a standard V/Oct keyboard will input a microtone.

If you change your Octave Division after you composed a melody in 12EDO, the input melody will still be available but scaled to the first 12 tones of the new scale. To hear your original melody again, simply return to the standard 12EDO.

9.3 CUSTOM SCALES

Besides the built-in scales, it is possible to create up to four scales per each octave division (12, 15, 19, 22, and 24 intervals), for a total of 20 user scales.

This operation must be performed on a computer, as it requires the creation of a .csv file which must be then loaded into the SD card. To create the .csv file we recommend using a flexible text editor, such as [Atom](#): other editors or word processors might add some unwanted data to the file, such as text formatting, which may make it unreadable for USTA.

The .csv file must be made of four lines, one per each custom scale. Each line must have a succession of digits, which can be only 0 and 1, and must be separated by a semicolon (;). The digit represents the semitones, which can be either active (1) or bypassed (0) during the quantization process. The digits will be 12 for the 12-tone scales, 15 for the 15-tone scales, and so on, up to the 24-tone scale. No space must be used between digits and semicolons, and no semicolon must be placed after the last digit.

Here is an example of how a .csv file for four custom 12-tone scales will look like: the first scale is chromatic, the second major natural, the third minor natural, and the fourth chromatic.

```
1;1;1;1;1;1;1;1;1;1;1;1
1;0;1;0;1;1;0;1;0;1;0;1
1;0;1;1;0;1;0;1;1;0;1;0
1;1;1;1;1;1;1;1;1;1;1;1
```

Please note that the four lines must be completed in full for the file to be properly read by USTA: if you need to create less than four custom scales, consider filling the other lines with something, for example, chromatic scales (all 1s).

If an interval is missing at the end of each line, it will be replaced with a 0. Values after the last one will be ignored. Once your file is ready, you must save it as follows:

Number of tones per octave	File name
12	12scales.csv
15	15scales.csv
19	19scales.csv
22	22scales.csv
24	24scales.csv

Table 15: Custom scales file names.

Once the files are correctly saved, copy them to the root of the SD card, and insert the card into the card holder in the back of USTA. On startup, USTA will automatically read the new scales, which will be available as `User1`, `User2`, `User3`, and `User4` under each octave division scale section, at the end of the track menu. To unmount the SD card and connect it to your computer, refer to the procedure listed in the following sections about *Project Management* or *Firmware Update* (§§ [10.3-10.4](#)).

If no .csv file is found on the SD card, or if the file loaded is not readable by USTA, the four user scales will be replaced by chromatic scales, which is also the condition of USTA at its first boot.

9.4 SET THE REFERENCE NOTE

Traditionally 0 V—in the V/oct tracking reference—is intended to be a C. Since the V/oct standard is not absolute but relative, and since that voltage reference truly depends on the tuning frequency at 0 V of the oscillator you are using, it seems that some people prefer the C at 0 V, while some others prefer the A: in the end, it’s just personal taste, even here at Frap Tools we are divided.

We thus decided to put a setting item in the project menu to define that per each project. This is only a visual reference but, in this way, everyone can maintain their preferred way of seeing things, to ease the creation and arrangement. The only thing that changes selecting the one or the other is the visualization on the display of the name value of the last edited stage and the current playing stage in a track that uses a *Pitch* mode for their *CV A* or *CV B*.

To set the reference note, open the Project Menu, scroll to the item 0V is, and select C or A.

9.5 CUSTOM TEMPERAMENTS

USTA by default divides an octave in equal temperaments, which means that the distance between each interval is the same across the whole scale, regardless of how many intervals per octave are chosen. It is possible, however, to create custom tunings to fine-tune certain scale intervals and obtain, for instance, more “perfect” intervals such as thirds or fifths.

The procedure is like the one just described for custom scales: a .csv file is required for each of the octave divisions (12, 15, 19, 22, 24 intervals) and the custom scales will be available as an option in the `TonesPerOct` menu item.

By default, no file is loaded into the SD card, and these menu items will be a copy of their respective EDO temperaments. The .csv file must be made of four lines, one per each custom temperament. Each line must have a succession of digits, which represent the tuning offset from EDO, expressed in cents, and whose values can be anything from -50 to +50. They must be separated by a semicolon (;) and there must be 12 for the 12-tone scales, 15 for the 15-tone scale, and so on, up to the 24-tone scale. No space must be used between digits and semicolons, and no semicolon must be placed after the last digit.

Please note that the custom temperaments will not be audible in *Composition* mode, where they are replaced by the default EDO. Temperaments are audible when USTA is playing the sequence either in *Edit* or *Playback* mode.

Here is an example of how a single line of the .csv file for a custom 12-tone temperament will look like.

0;0;5;0;-7;0;0;11;0;-2;0;0

Here the major second is raised by 5 cents, the major third is lowered by 7, the fifth is raised by 11 and the sixth is lowered by two.

Please note that the four lines must be completed in full for the file to be properly read by USTA: if you need to create less than four custom temperaments, consider filling the other lines with 0s.

If a value is missing at the end of each line, it will be replaced with a 0. Values after the last one will be ignored. Once your file is ready, you must save it as follows:

Number of tones per octave	File name
12	12temper.csv
15	15temper.csv
19	19temper.csv
22	22temper.csv
24	24temper.csv

Table 16: Custom temperaments file names.

Once the files are correctly saved, copy them to the SD card and insert the card into the card holder in the back of USTA. On startup, USTA will automatically read them and the temperaments will be available as `12User1`, `12User2`, `12User3`, `12User4`, `15User1`, `15User2`, and so on, within the `TonesPerOct` item in the track menu. To unmount the SD card and connect it to your computer, refer to the procedure listed in the following sections about *Project Management* or *Firmware Update* (§§ 10.3-10.4).

9.5.1 Absolute or Relative Temperaments

After defining your tuning, it is possible to choose whether quantization is calculated by USTA based on the 0 V note (absolute) or in relation to the Root note selected for the respective octave division (relative).

The reason for doing so is that one may need a given temperament for different compositions in different keys. To set this option, enter the Project Menu, scroll until the `Temperament` item, and select `Relative` or `Absolute` as the default behavior. These settings are stored in each project file and can be thus different from piece to piece.

The .csv files created for Scales and Temperaments are global parameters, just like the trimming file. It means that they are not saved in each project, but they are recalled every time. If you need a specific scale or temperament for a project, make sure not to replace it on the .csv file!

9.6 LED PITCH TABLES

semi-tones													
	0 V is C	C	C#	D	D#	E	F	F#	G	G#	A	A#	B
	0 V is A	A	A#	B	C	C#	D	D#	E	F	F#	G	G#
	Voltage	0 V	1/12 V ~0.083V	2/12 V ~0.166V	3/12 V 0.25V	4/12 V ~0.333V	5/12 V ~0.416V	6/12 V 0.5 V	7/12 V ~0.583V	8/12 V ~0.666	9/12 V 0.75V	10/12 V ~0.833V	11/12 V ~0.916V
octaves													
	Octave	+0	+1	+2	+3	+4	+5	+6	+7	+8	+9	+10	
	Voltage	0 V	1V	2V	3V	4V	5 V	6V	7V	8V	0 V	0 V	

Table 17: 12-EDO LED chart.

semi-tones													
	0 V is C	C	C#	D	D#	E	E#	F	F#	G	G#	Ab	A
	0 V is A	A	A#	B	B#	C	C#	D	D#	E	E#	F	F#
	Voltage	0 V	1/15V ~0.066V	2/15V ~0.133V	3/15V 0.2V	4/15V ~0.266V	5/15V ~0.333V	6/15V 0.4V	7/15V ~0.466V	8/15V ~0.533	9/15V 0.6V	10/15V ~0.666V	11/15V ~0.733V
semi-tones													
	0 V is C	A#	B	B#									
	0 V is A	G	G#	Ab									
	Voltage	12/15V ~0.8V	13/15V ~0.866V	14/15V ~0.933V									
octaves													
	Octave	+0	+1	+2	+3	+4	+5	+6	+7	+8			
	Voltage	0 V	1V	2V	3V	4V	5 V	6V	7V	8V			

Table 18: 15-EDO LED chart.

semi-tones													
	0 V is C	C	C#	Db	D	D#	Eb	E	E#	F	F#	Gb	G
	0 V is A	A	A#	Bb	B	B#	C	C#	Db	D	D#	Eb	E
	Voltage	0 V	1/19V ~0.052V	2/19V ~0.105V	3/19V ~0.157V	4/19V ~0.210V	5/19V ~0.263V	6/19V ~0.315V	7/19V ~0.368V	8/19V ~0.421	9/19V~ 0.473V	10/19V ~0.526V	11/19V ~0.578V
semi-tones													
	0 V is C	G#	Ab	A	A#	Bb	B	B#					
	0 V is A	E#	F	F#	Gb	G	G#	Ab					
	Voltage	12/19V ~0.631V	13/19V 0.684V	14/19V ~0.736V	15/19V ~0.789V	16/19V ~0.842V	17/19V ~0.894V	18/19V ~0.947V					
octaves													
	Octave	+0	+1	+2	+3	+4	+5	+6					
	Voltage	0V	1V	2V	3V	4V	5 V	6V					

Table 19: 19-EDO LED chart.

0 V is C	C	C#	Db	D	D#	Eb	E	E#	Fb	F	F#	Gb	
0 V is A	A	A#	Bb	B	B#	Cb	C	C#	Db	D	D#	Eb	
Voltage	0 V	1/22V ~0.045V	2/22V ~0.090V	3/22V ~0.136V	4/22V ~0.181V	5/22V ~0.227V	6/22V ~0.272V	7/22V ~0.318V	8/22V ~0.363	9/22V ~0.409V	10/22V ~0.454V	11/22V 0.5 V	
semi-tones													
0 V is C	G	G#	Abb	Ab	A	A#	Bb	B	B#	Cb			
0 V is A	E	E#	Fb	F	F#	Gb	G	G#	Abb	Ab			
Voltage	12/22V ~0.545V	13/22V ~0.590V	14/22V ~0.636V	15/22V ~0.681V	16/22V ~0.727V	17/22V ~0.772V	18/22V ~0.818V	19/22V ~0.863V	20/22V ~0.909V	21/22V ~0.954V			
octaves													
Octave	+0	+1	+2	+3	+4	+5							
Voltage	0 V	1V	2V	3V	4V	5 V							

Table 20: 22-EDO LED chart.

0 V is C	C	C^	C#	Dv	D	D^	D#	Ev	E	E^	F	F^	
0 V is A	A	A^	A#	Bv	B	B^	C	C^	C#	Dv	D	D^	
Voltage	0 V	1/24V ~0.041V	2/24V ~0.083V	3/24V 0.125V	4/24V ~0.166V	5/24V ~0.208V	6/24V 0.25V	7/24V ~0.291V	8/24V ~0.333	9/24V 0.375V	10/24V ~0.416V	11/24V ~0.458V	
semi-tones													
0 V is C	F#	Gv	G	G^	G#	Av	A	A^	A#	Bv	B	B^	
0 V is A	D#	Ev	E	E^	F	F^	F#	Gv	G	G^	G#	Av	
Voltage	12/24V 0.5 V	13/24V ~0.541V	14/24V ~0.583V	15/24V 0.625V	16/24V ~0.666V	17/24V ~0.708V	18/24V 0.75V	19/24V ~0.791V	20/24V ~0.833V	21/24V 0.875V	22/24V ~0.916V	23/24V ~0.958V	
octaves													
Octave	+0	+1	+2	+3	+4								
Voltage	0 V	1V	2V	3V	4V								

Table 21: 24-EDO LED chart.

10 ADDITIONAL MAINTENANCE

10.1 REMOVE/INSERT THE SD CARD

For some operations, it is required to remove and then reinsert the SD card. We won't copy/paste the same process here every time so here's how to do that.

10.1.1 Remove the SD Card

- (a) Turn off the module.
- (b) Unmount it from your case removing all the screws.
- (c) Unplug the module power cable.
- (d) Take off the SD card from the back of the module by pushing it (it's a push-push mechanism).

10.1.2 Insert the SD Card

- (e) Safe remove the SD card from the computer.
- (f) Put the SD card back in place onto the module: if you are looking at the back of the module, the SD card contacts should look at you. Insert the SD card into the SD card holder and push to retain it.
- (g) Plug the module power cable.
- (h) Remount it safely in your case using all the screws.
- (i) You can now turn on the module.

10.2 ANALOG TRIMMING

The trimming routine is an alternative way to start the machine, to perform, set, and adjust digital trimming on any of the CV output or input.

Each unit's CV inputs and outputs are software calibrated to guarantee the most precise response. For this purpose, it is highly recommended to make a backup copy of your USTA's trimming file. To do so, unmount the SD card (see instructions above), connect it to your computer, and copy the file labeled `trim.cfg`, then place the SD card back into the module (see instructions above). Should you lose somehow the file on the SD card, USTA will automatically create a new trimming file with default values, which may cause imprecise tracking.

To access the *Trimming* turn off the USTA, hold the *Play/Pause* button (B.13), and turn on the USTA again.

The trimming menu will show you 32 settings for the outputs and four settings for the inputs. Each output or input needs to be set for -5 V , 0 V , $+5\text{ V}$, and $+10\text{ V}$. Scroll through elements with the navigation encoder, push it to start to modify the value, and push again to confirm it.

For best results, we strongly suggest warming up the USTA at least for 30 minutes inside the case where it will be used before performing any sort of trimming.

10.2.1 CV Out Trimming

To perform the trimming on the outputs a multimeter is needed. Consider also the precision of the multimeter you are using.

The USTA outputs are based on an octal 16-bit DAC, with $65\,536$ steps: the maximum output without trimming is from around -5.5 V up to around $+10.5\text{ V}$, which translates to 16 V of range and an amplitude difference between each step of around 0.244 mV .

The CV outputs are numbered from 1 to 8, from top to bottom, like:

- Track 1 CV A = `OUT1`
- Track 1 CV B = `OUT2`
- Track 2 CV A = `OUT3`
- Track 2 CV B = `OUT4` ...

And so on. Each output has four values to calibrate: -5 V , 0 V , $+5\text{ V}$, and $+10\text{ V}$. Here's how to perform the calibration.

- (a) Patch the desired output's -5 V to a multimeter.
- (b) Push the navigation encoder on the corresponding value.
- (c) Check the current voltage output.
- (d) Rotate the navigation encoder to calibrate the value.
- (e) Push the navigation encoder to confirm.

Then repeat the operation for the three remaining voltages of the corresponding output.

10.2.2 CV In Trimming

To perform the trimming on the inputs, a precise voltage generator is needed, with the capability to generate from at least -5.5 V up to $+10.5\text{ V}$.

On the Trimming page, you will see two updating numbers at the bottom, these are the CV A and B input monitors.

- (a) Patch a -5 V signal to your CV A input.
- (b) Scroll down to the `IN1` row.
- (c) Check that the `IN1 -5V` value is close to the bottom-left updating number. If not, tweak it until it does.
- (d) Patch a `10V` signal to CV A.
- (e) Scroll to the `IN1 10V` row.
- (f) Repeat point (c) for the `IN1 10V` values.
- (g) Repeat the operation for CV B (`IN2 -5` and `IN2 10`). For this procedure, use the input monitor on the bottom right.

To save what you did, push the play button.

When you are done, you can turn off and normally turn on again the USTA.

10.3 PROJECT MANAGEMENT AND BACKUPS

Projects can be backed up on your computer, and it is strongly suggested to back them up. To do so:

Turn off and unplug your case.

Remove the SD Card (follow the instructions above).

Connect the SD card to the computer you want to use for backups.

Copy/paste the project files you want to save from the SD card root to your computer.

The project is now backed up.

Insert the SD Card (follow the instructions above).

10.4 FIRMWARE UPDATE

- (a) Turn off and unplug your case.
- (b) Remove the SD Card (follow the instructions above).
- (c) Download the firmware file from <https://frap.tools/firmwares/> to your computer. Some operating systems might display the .bin file with a compressed document icon, but it is not, so there's no need to decompress it.
- (d) Connect the SD card to that computer.

- (e) Rename the downloaded file as *USTA.bin* (keep the extension .bin, it is important.)
- (f) Place the renamed file on the root of the SD card, replacing the older USTA.bin file.
- (g) Insert the μ SD Card and plug the USTA back into the case (follow previous instructions).
- (h) Power up your system.
- (i) Once USTA has booted, press and hold the navigation encoder to enter the project menu.
- (j) Scroll until you find the **REPLACE FW** and push the encoder. A window will open, asking for confirmation. By default, the answer is **NO**, to prevent accidental misbehaviors. Rotate the navigation encoder counterclockwise to select **YES**, then push the encoder to launch the upgrade.

The device will automatically reboot and begin the update procedure. You must wait for it to complete the update before using it normally. **DO NOT TURN OFF POWER FROM THIS POINT, OR IT WILL VOID YOUR MODULE'S WARRANTY!**

11 CHARTS

11.1 PROJECT MENU

Menu voice	Selectable options	Function
New...	—	Creates a new file.
Load...	—	Loads any existent file.
Save	—	Saves the changes made to the current project.
Save As...	—	Saves the current project as a new file.
Delete...	—	Deletes any existent file.
Rename...	—	Renames any existent file.
Aux Target	Reset/Run 1/Run 2/Run 3/ Run 4	Selects the behavior of the external gate signal.
Master Track	1/2/3/4	Selects the Master Track.
ShowInPlay	No/Yes	Enable to display in real time the playing stage in PerformanceMode in the dashboard.
0 U is	C/A	Selects the Reference Note.
All Edits	From/All	Selects the behavior of the Set All and Shift All buttons.
Temperament	Absolute/Relative	Selects if the User Temperaments are applied to the Reference Note only, or to the root note selected in each track (which may change).
Replace FW	—	Updates the current firmware (when a new firmware file is loaded into the SD card).

11.2 TRACK MENU

Menu voice	Selectable options	Function
Int BPM	from 30 to 300	Select the internal clock speed expressed in BPM, the clock source, and the clock-to-unit ratio, as expressed in the chapters about Tempo Management and Editing Tracks.
ClockSource	Built-In/External	
Ratio	...	
Swing	0 - 50	Sets the Swing ratio.
Track Mode	Pattern/Song	Selects the track mode.
CV A Mode	Pitch/Raw	Sets the CV mode for channel A and B to raw voltages or quantized notes.
CV B Mode	Pitch/Raw	
CV A Range	0/+10 V/-/+5 V	
CV B Range	0/+10 V/-/+5 V	Defines if the CV range for channel A and B is unipolar or bipolar.
Root	C - B	
Scale	...	
Quantize	Near Up/ Near Down/ Up/ Down	Selects the dynamic quantization direction.
Gate A % Width	10 - 90	Sets the time a gate stays high when in ratcheting mode (green color), expressed in the % of the time between two consecutive rising edges.
Gate B % Width	10 - 90	
Reset What	Nothing/ Stage/ Stage&Pa	Select the reset options.
Reset On	Instant/ Local/ Master	
PitchShiftA	None/ CV A/ CV B	Sets the Pitch Shift source for CV A and B.
PitchShiftB	None/ CV A/ CV B	
Root Shift	None/ CV A/ CV B	Sets the Root Shift source.
StageShift	None/ CV A/ CV B	Sets the Stage Shift source.
Ptrn Shift	None/ CV A/ CV B	Sets the Pattern Shift source.
PhaseShift	None/ CV A/ CV B	Sets the Phase Shift source.
Gate ShiftA	None/ CV A/ CV B	Sets the Gate Shift source for GATE A and B.
Gate ShiftB	None/ CV A/ CV B	
Vari Shift	None/ CV A/ CV B	Sets the Variation Shift source.
TonesPerOct	...	Sets the octave division unit or the custom temperament.
Root 15	...	Select the reset options. Defines the root and scale for each of the other four octave divisions available. See also the following sections about. 15, 19, 22 and 24-EDO scales.
Scale 15	...	
Root 19	...	
Scale 19	...	
Root 22	...	
Scale 22	...	
Root 24	...	
Scale 24	...	

11.3 PROJECT HIERARCHY

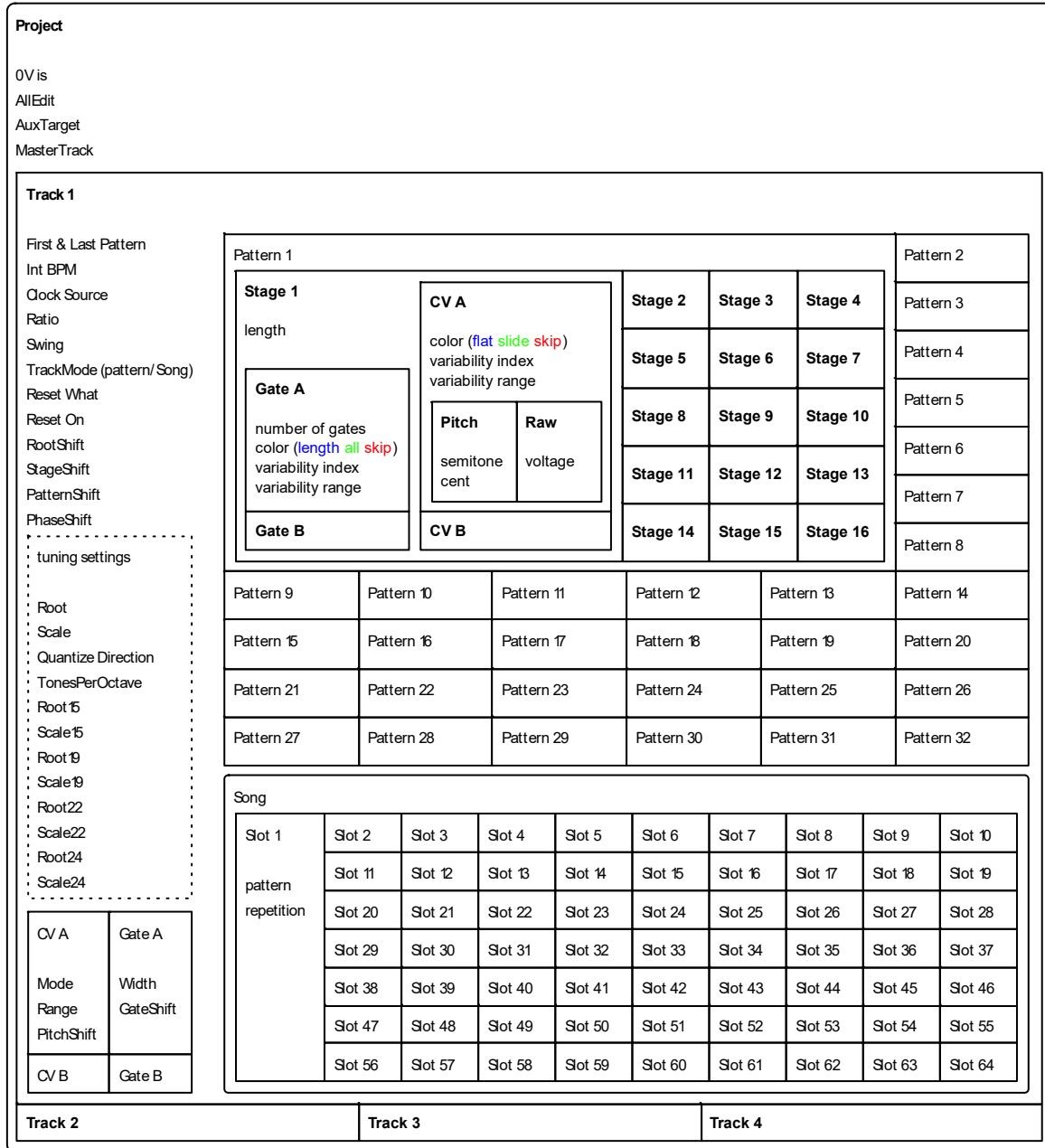

Figure 94: USTA structure.

12 SCALE TABLES

Table 22: 12-EDO and other 12-tone-per-octave temperaments.

description	t/oct	tone cents display	0	1	2	3	4	5	6	7	8	9	10	11
			0	100	200	300	400	500	600	700	800	900	1000	1100
			Chromatic	12	Chroma	1	1	1	1	1	1	1	1	1
Major Pentatonic 1	5	5 Maj 1	1	0	1	0	1	0	0	1	0	1	0	0
Minor Pentatonic 2	5	5 Min 2	1	0	1	0	0	1	0	1	0	0	1	0
Minor Pentatonic 3	5	5 Min 3	1	0	0	1	0	1	0	0	1	0	1	0
Major Pentatonic 2	5	5 Maj 2	1	0	1	0	0	1	0	1	0	1	0	0
Minor Pentatonic 1	5	5 Min 1	1	0	0	1	0	1	0	1	0	0	1	0
Dominant Pentatonic	5	5 Domin	1	0	1	0	1	0	0	1	0	0	1	0
Whole Tone	6	6 Whole	1	0	1	0	1	0	1	0	1	0	1	0
Augmented	6	6 Augmt	1	0	0	1	1	0	0	1	1	0	0	1
Prometheus	6	6 Mgsto	1	0	1	0	1	0	1	0	0	1	1	0
Hexatonic Blues	6	6 Blues	1	0	0	1	0	1	1	1	0	0	1	0
Ionian	7	Ionian	1	0	1	0	1	1	0	1	0	1	0	1
Dorian	7	Dorian	1	0	1	1	0	1	0	1	0	1	1	0
Phrygian	7	Phrygia	1	1	0	1	0	1	0	1	1	0	1	0
Lydian	7	Lydian	1	0	1	0	1	0	1	1	0	1	0	1
Mixolydian	7	Mixo	1	0	1	0	1	1	0	1	0	1	1	0
Aeolian	7	Aeolian	1	0	1	1	0	1	0	1	1	0	1	0
Locrian	7	Locrian	1	1	0	1	0	1	1	0	1	0	1	0
Harmonic Minor – Aeolian #7, m Harmonic Modes	7	mHarmon	1	0	1	1	0	1	0	1	1	0	0	1
Locrian #6	7	Locri#6	1	1	0	1	0	1	1	0	0	1	1	0
Ionian #5	7	Ionia#5	1	0	1	0	1	1	0	0	1	1	0	1
Dorian #4	7	Doria#4	1	0	1	1	0	0	1	1	0	1	1	0
Phrygian Dominant	7	PhryDom	1	1	0	0	1	1	0	1	1	0	1	0
Lydian #2	7	Lydia#2	1	0	0	1	1	0	1	1	0	1	0	1
Ultralocrian	7	uLocria	1	1	0	1	1	0	1	0	1	1	0	0
Melodic Minor, Jazz Minor	7	mMelodi	1	0	1	1	0	1	0	1	0	1	0	1
Dorian b9	7	Doriab9	1	1	0	1	0	1	0	1	0	1	1	0
Lydian Augmented	7	LydiAug	1	0	1	0	1	0	1	0	1	1	0	1
Lydian Dominant	7	LydiDom	1	0	1	0	1	0	1	1	0	1	1	0
Mixolydian b6	7	Mixo b6	1	0	1	0	1	1	0	1	1	0	1	0
Semilocrian, Aeolian b5	7	sLocria	1	0	1	1	0	1	1	0	1	0	1	0
Superlocrian	7	SuLocri	1	1	0	1	1	0	1	0	1	0	1	0
Double Harmonic Major	7	dHarmMa	1	1	0	0	1	1	0	1	1	0	0	1
Lydian #2 #6	7	Lyd#2#6	1	0	0	1	1	0	1	1	0	0	1	1
UltraPhrygian, Ultralocrian natural 5	7	uPhrygi	1	1	0	1	1	0	0	1	1	1	0	0
Double Harmonic Minor, Hungarian Minor	7	dHarmMi	1	0	1	1	0	0	1	1	1	0	0	1
Mixolydian b2 b5, Oriental	7	Mixb2b5	1	1	0	0	1	1	1	0	0	1	1	0
Ionian Augmented #2	7	IoAug#2	1	0	0	1	1	1	0	0	1	1	0	1
Locrian bb3 bb7	7	Locbb37	1	1	1	0	0	1	1	0	1	1	0	0
Hungarian Major	7	Hungari	1	0	0	1	1	0	1	1	0	1	1	0
Superlocrian bb6 bb7	7	SuLbb67	1	1	0	1	1	0	1	1	0	1	0	0
Harmonic Minor b5	7	mHarmb5	1	0	1	1	0	1	1	0	1	0	0	1
Superlocrian #6	7	SuLoc#6	1	1	0	1	1	0	1	0	0	1	1	0
Melodic Minor #5, Jazz Minor #5	7	mMelo#5	1	0	1	1	0	1	0	0	1	1	0	1
Dorian b9 #11	7	Dor#4b9	1	1	0	1	0	0	1	1	0	1	1	0
Lydian Augmented #3	7	LydAu#3	1	0	1	0	0	1	1	0	1	1	0	1
Harmonic Major, Ionian b6	7	MHarmon	1	0	1	0	1	1	0	1	1	0	0	1
Dorian b5	7	Doriab5	1	0	1	1	0	1	1	0	0	1	1	0
Phrygian b4	7	Phrysb4	1	1	0	1	1	0	0	1	1	0	1	0
Lydian b3	7	Lydiab3	1	0	1	1	0	0	1	1	0	1	0	1
Mixolydian b9	7	Mixo b9	1	1	0	0	1	1	0	1	0	1	1	0
Lydian Augmented #2	7	LydAu#2	1	0	0	1	1	0	1	0	1	1	0	1
Locrian bb7	7	Loc bb7	1	1	0	1	0	1	1	0	1	1	0	0
Neapolitan Major	7	MNeapol	1	1	0	1	0	1	0	1	0	1	0	1
Leading Whole-Tone	7	LeaWhol	1	0	1	0	1	0	1	0	1	0	1	1
Lydian Augmented Dominant	7	LydAuDo	1	0	1	0	1	0	1	0	1	1	1	0
Lydian Dominant b6	7	LydDob6	1	0	1	0	1	0	1	1	1	0	1	0
Major Locrian	7	MLocria	1	0	1	0	1	1	1	0	1	0	1	0
Semilocrian b4	7	sLoc b4	1	0	1	1	1	0	1	0	1	0	1	0
Superlocrian bb3	7	SuLobb3	1	1	1	0	1	0	1	0	1	0	1	0
Neapolitan Minor	7	mNeapol	1	1	0	1	0	1	0	1	1	0	0	1
Lydian #6	7	Lydia#6	1	0	1	0	1	0	1	1	0	0	1	1
Mixolydian Augmented	7	MixoAug	1	0	1	0	1	1	0	0	1	1	1	0
Aeolian #4, Hungarian Gipsy	7	Aeoli#4	1	0	1	1	0	0	1	1	1	0	1	0
Locrian Dominant	7	Loc Dom	1	1	0	0	1	1	1	0	1	0	1	0
Ionian #2	7	Ionia#2	1	0	0	1	1	1	0	1	0	1	0	1
Ultralocrian bb3	7	uLocbb3	1	1	1	0	1	0	1	0	1	1	0	0

Chromatic Hypolydian	7	hc Lydi	1	1	0	0	1	0	1	1	1	0	0	1
Chromatic Hypophrygian	7	hc Phri	1	0	0	1	0	1	1	1	0	0	1	1
Chromatic Hypodorian	7	hc Dor1	1	0	1	1	1	0	0	1	1	1	0	0
Chromatic Mixolydian	7	hc Mixo	1	1	1	0	0	1	1	1	0	0	1	0
Chromatic Lydian	7	o Lydia	1	1	0	0	1	1	1	0	0	1	0	1
Chromatic Phrygian	7	o Phryg	1	0	0	1	1	1	0	0	1	0	1	1
Chromatic Dorian	7	o Doria	1	1	1	0	0	1	0	1	1	1	0	0
Chromatic Hypophrygian inverse	7	hciPhryg	1	1	1	0	0	1	1	1	0	1	0	0
Chromatic Hypolydian inverse	7	hciLydi	1	1	0	0	1	1	1	0	1	0	0	1
Chromatic Dorian inverse	7	hciDor1	1	0	0	1	1	1	0	1	0	0	1	1
Chromatic Phrygian inverse	7	hciPhri	1	1	1	0	1	0	0	1	1	1	0	0
Chromatic Lydian inverse	7	oi Lydi	1	1	0	1	0	0	1	1	1	0	0	1
Chromatic Mixolydian inverse	7	oi Mixo	1	0	1	0	0	1	1	1	0	0	1	1
Chromatic Hypodorian inverse	7	oi Dor1	1	0	0	1	1	1	0	0	1	1	1	0
BeBop Major	8	bbp Maj	1	0	1	0	1	1	0	1	1	1	0	1
BeBop Dominant	8	bbp Dom	1	0	1	0	1	1	0	1	0	1	1	1
BeBop Dorian	8	bbp Dor	1	0	1	1	1	1	0	1	0	1	1	0
BeBop Dorian Alternative	8	bbp DoA	1	0	1	1	0	1	0	1	0	1	1	1
BeBop Minor	8	bbp Min	1	0	1	1	0	1	0	1	1	1	0	1
BeBop Locrian	8	bbp Loc	1	1	0	1	0	1	1	1	1	0	1	0
BeBop Harmonic Minor – Natural Minor	8	bbp mHa	1	0	1	1	0	1	0	1	1	0	1	1
Diminished, Whole-Half	8	Diminis	1	0	1	1	0	1	1	0	1	1	0	1
Octatonic, Half-Whole	8	Octaton	1	1	0	1	1	0	1	1	0	1	1	0
	12	User 1	1	1	1	1	1	1	1	1	1	1	1	1
	12	User 2	1	1	1	1	1	1	1	1	1	1	1	1
	12	User 3	1	1	1	1	1	1	1	1	1	1	1	1
	12	User 4	1	1	1	1	1	1	1	1	1	1	1	1

Table 23: 15-EDO and other 15-tone-per-octave temperaments.

description	t/oct	tone	cents															
			0	80	160	240	320	400	480	560	640	720	800	880	960	1040	1120	
display																		
Chromatic	15	Chroma	1	1	1	1	1	1	1	1	1	1	1	1	1	1	1	1
Blackwood	6	6 Blackw	1	0	0	0	1	1	0	0	0	1	1	0	0	0	0	1
15 Tone Miller Porcupine 7	7	7 Miller	1	0	1	0	1	0	1	0	0	1	0	1	0	1	0	
15 Tone Miller Porcupine 7 Major	7	7 Miller	1	0	0	1	0	1	0	1	0	1	0	1	0	1	0	
Miller's Kusiro	8	8 Kusir	1	1	0	0	1	0	1	0	0	1	1	1	0	1	0	
15 Tone Major, Jones's Porcupine 8	8	8 JonesM	1	0	1	0	1	1	0	1	0	1	0	1	0	1	0	
Rempt's Andal	9	9 Rempt	1	0	1	0	1	1	0	1	0	1	1	0	1	0	1	
Blackwood	10	10Blackw	1	1	0	1	1	0	1	1	0	1	1	0	1	1	0	
15 Tone Major-Minor Mix	10	10MmMix	1	0	0	1	1	1	0	0	1	1	1	0	1	1	1	
12 Tone Chromatic	12	12Chrom	1	1	0	1	1	1	1	0	1	1	1	1	1	0	1	
	15	User 1	1	1	1	1	1	1	1	1	1	1	1	1	1	1	1	
	15	User 2	1	1	1	1	1	1	1	1	1	1	1	1	1	1	1	
	15	User 3	1	1	1	1	1	1	1	1	1	1	1	1	1	1	1	
	15	User 4	1	1	1	1	1	1	1	1	1	1	1	1	1	1	1	

Table 24: 19-EDO and other 19-tone-per-octave temperaments.

description	t/oct	tone cents display	0	1	2	3	4	5	6	7	8	9	10	11	12	13	14	15	16	17	18
			0,0	63,2	126,3	189,5	252,6	315,8	378,9	442,1	505,3	568,4	631,6	694,7	757,9	821,1	884,2	947,4	1010,5	1073,7	1136,8
Chromatic	19	Chroma	1	1	1	1	1	1	1	1	1	1	1	1	1	1	1	1	1	1	1
Four out of 19	4	Four	1	0	0	0	0	1	0	0	0	0	1	0	0	0	0	1	0	0	0
Five out of 19	5	Five	1	0	0	0	0	1	0	0	0	0	1	0	0	0	1	0	0	1	0
Quasi-Equal Pentatonic	5	qPenta	1	0	0	0	0	1	0	0	0	0	1	0	0	1	0	0	1	0	0
Yasser's Hexad	6	6 Yasser	1	0	0	1	0	0	1	0	0	1	0	0	1	0	0	1	0	0	0
Oljare Diminished	7	7 Olj D	1	0	0	0	0	1	1	0	0	0	1	1	0	0	0	1	1	0	0
Oljare Diminished	7	7 Olj A	1	0	0	0	0	1	1	0	0	0	0	1	1	1	1	0	0	0	1
Oljare Octatonic	8	8 OlJar	1	0	1	0	1	0	0	1	0	1	0	1	0	0	1	0	1	0	0
Oljare Pentaenharmonic	9	9 PenEn	1	1	0	0	1	1	0	0	1	0	0	1	1	0	0	1	1	0	0
Negri's Ten Plus Nine	10	10 Negri	1	0	1	0	1	0	1	0	1	0	1	0	1	0	1	0	1	0	1
Keenan eleven out of 19	11	11 Keen	1	0	0	1	1	1	0	0	1	1	0	0	1	1	1	0	0	1	1
Krantz eleven out of 19	11	11 Kranz	1	0	1	0	1	0	1	0	1	0	1	0	1	1	0	1	0	1	0
McLaren eleven out of 19	11	11 McLa	1	0	0	1	1	1	0	0	1	1	1	1	1	0	0	1	1	0	0
Gould Eleven out of 19	11	11 Goul	1	0	1	0	1	1	0	1	0	1	0	1	1	0	1	0	1	0	1
Meantone Chromat (1/3 comma)	12	MeanChr	1	1	0	1	0	1	1	0	1	1	0	1	1	0	1	0	1	1	0
Genus Diatonic-Chromaticum	12	GenuChr	1	0	1	1	0	1	1	0	1	1	0	1	1	0	1	1	0	1	1
Yasser's Supradiatonic	12	SupraDi	1	0	1	1	0	1	1	0	1	0	1	1	0	1	1	0	1	1	0
Mandelbaum's Eight out of 19	8	8 Mandle	1	0	1	0	0	1	0	1	0	1	0	0	1	0	1	0	1	0	0
Mandelbaum's Nine out of 19	9	9 Mandle	1	0	1	0	1	0	0	1	0	1	0	1	0	1	0	1	0	1	0
Mandelbaum's Ten out of 19	10	10Mandle	1	0	1	0	1	1	0	1	0	1	0	1	0	1	0	1	0	1	0
Mandelbaum's Eleven out of 19	11	11Mandle	1	0	1	1	0	1	0	1	0	1	1	0	1	0	1	0	1	1	0
Mandelbaum's Twelve out of 19	12	12Mandle	1	1	0	1	1	0	1	0	1	1	0	1	1	0	1	1	0	1	0
Mandelbaum's Thirteen out of 19	13	13Mandle	1	0	1	1	0	1	1	0	1	1	0	1	1	0	1	1	0	1	1
Mandelbaum's Fourteen out of 19	14	14Mandle	1	1	0	1	1	1	0	1	1	1	0	1	1	1	0	1	1	0	1
	19	User 1	1	1	1	1	1	1	1	1	1	1	1	1	1	1	1	1	1	1	1
	19	User 2	1	1	1	1	1	1	1	1	1	1	1	1	1	1	1	1	1	1	1
	19	User 3	1	1	1	1	1	1	1	1	1	1	1	1	1	1	1	1	1	1	1
	19	User 4	1	1	1	1	1	1	1	1	1	1	1	1	1	1	1	1	1	1	1

Table 25: 22-EDO and other 22-tone-per-octave temperaments.

description	t/oct	tone cents display	0	1	2	3	4	5	6	7	8	9	10	11	12	13	14	15	16	17	18	19	20	21
			0.0	54.5	109.1	163.6	218.2	272.7	327.3	381.8	436.4	490.9	545.5	600.0	654.5	709.1	763.6	818.2	872.7	927.3	981.8	1036.4	1090.9	1145.5
Chromatic	15	Chroma	1	1	1	1	1	1	1	1	1	1	1	1	1	1	1	1	1	1	1	1	1	1
Twelve-tone Chromatic (1/3-comma positive)	12	12Chrom	1	0	0	1	1	1	0	0	1	1	0	0	1	1	0	0	1	1	1	0	0	1
22 tone Major	7	Major	1	0	0	0	1	0	0	0	1	1	0	0	0	1	0	0	0	1	0	0	0	1
22 tone Melodic Minor	7	mMelodi	1	0	0	0	1	0	1	0	0	1	0	0	1	0	0	1	0	0	0	0	1	0
22 tone Harmonic Minor	7	mHarmon	1	0	0	0	1	0	1	0	0	1	0	0	0	1	0	1	0	0	0	0	1	0
22 tone Harmonic Major	7	MHarmon	1	0	0	0	1	0	0	1	0	1	0	0	0	1	0	1	0	0	0	0	1	0
22 tone Astrology-10	10	Astrolo	1	0	0	1	1	0	0	1	0	0	1	1	0	0	1	1	0	0	1	0	0	1
22 tone Doublewide-10	10	Dbliw10	1	1	0	0	0	1	1	0	0	0	1	1	1	0	0	0	1	1	0	0	0	1
22 tone Doublewide-14	14	Dbliw14	1	1	1	0	0	1	1	1	0	0	1	1	1	1	0	0	1	1	1	0	0	1
22 tone Fleetwood-14	14	FItwo14	1	1	1	0	0	1	1	1	1	0	0	1	1	1	0	0	1	1	1	1	0	0
22 tone Hedgehog-6	6	Hedge 6	1	0	0	0	0	1	0	0	1	0	0	1	0	0	0	1	0	0	0	1	0	0
22 tone Hedgehog-8	8	Hedge 8	1	0	1	0	0	1	0	0	1	0	0	1	0	1	0	0	1	0	0	1	0	0
22 tone Hedgehog-14	14	Hedge14	1	0	1	1	0	1	0	1	1	0	1	1	0	1	1	0	1	0	1	1	0	1
22 tone Jubilee-12	12	Jubili12	1	0	1	0	1	1	0	1	0	1	0	1	0	1	0	1	1	0	1	0	1	0
22 tone Pajara-12	12	Pajar12	1	0	1	0	1	0	1	1	0	1	0	1	0	1	0	1	0	1	1	0	1	0
22 tone Supra-5, Septimal Minor Pentatonic	5	Supra 5	1	0	0	0	0	1	0	0	0	1	0	0	0	1	0	0	0	0	0	1	0	0
22 tone Supra-7	7	Supra 7	1	0	0	0	1	1	0	0	0	1	0	0	0	1	0	0	0	1	1	0	0	0
22 tone Supra-12	12	Supra12	1	1	0	0	1	1	0	0	1	1	1	0	0	1	1	0	0	1	1	0	0	1
22 tone Urchin-14	14	Supra14	1	0	1	0	1	1	0	0	1	1	0	1	0	0	1	1	0	1	1	0	1	1
22 tone Wilson Pi-Meantone	12	WilsoPi	1	0	0	1	1	0	0	1	1	0	0	1	1	1	0	0	1	1	0	1	0	1
Ionian Porcupine	7	IonioPo	1	0	0	0	1	0	0	1	0	1	0	0	0	1	0	0	1	0	0	1	0	0
Dorian Porcupine	7	DorioPo	1	0	0	0	1	0	1	0	0	1	0	0	0	1	0	0	1	0	0	1	0	0
Aeolian Porcupine	7	AeolioPo	1	0	0	1	0	0	1	0	0	1	0	0	0	1	0	1	0	1	0	0	1	0
Major Porcupine	7	MajorPo	1	0	0	0	1	0	0	1	0	0	1	0	0	1	0	0	1	0	0	0	1	0
Major-Minor Porcupine	7	MajMiPo	1	0	0	0	1	0	0	1	0	0	1	0	0	1	0	1	0	0	0	1	0	0
Chameleon Porcupine	7	ChamePo	1	0	0	0	1	0	0	1	0	0	1	0	0	1	0	0	0	1	0	0	1	0
Symmetric Diminished Porcupine	7	SymDimP	1	0	0	1	0	0	1	0	0	0	1	0	1	0	0	0	1	0	0	1	0	0
Porcupine-15	15	Porcu15	1	0	1	1	0	1	1	1	0	1	1	0	1	1	0	1	1	0	1	1	0	1
Elevenplus	12	Eleven+	1	0	1	0	1	0	1	0	1	0	1	0	1	1	0	1	0	1	0	1	0	1
Hexachordal	12	Hexacho	1	0	1	0	1	0	1	0	1	0	1	0	1	0	1	0	1	0	1	0	1	0
Noll Pseudo-diatonic	13	NollPSD	1	0	1	0	1	1	0	1	0	1	0	1	0	1	1	0	1	0	1	0	1	0
Ballooning Rushes	7	Balloon	1	0	0	1	1	0	0	0	0	0	1	0	1	0	0	0	0	0	0	1	1	0
Crushed Oranges	8	CrushOr	1	1	0	0	1	0	0	0	0	1	1	0	0	1	0	0	0	0	0	1	1	0
Kathartic Parts	7	Kathart	1	0	1	1	0	0	0	0	0	0	1	0	1	1	0	0	0	0	0	0	0	1
Rivetting Reds	9	Rivetti	1	1	0	0	0	1	1	0	0	0	1	0	1	1	0	0	0	1	1	0	0	0
Rodentalia	9	Rodenta	1	0	0	0	1	1	0	0	1	1	0	0	0	1	1	0	0	1	1	0	0	0
Rezsutek's Percussion Scale	9	Rezsute	1	0	1	0	0	1	0	1	0	0	1	0	1	0	0	1	0	1	0	0	1	0
22 tone Magic-7	7	Magic 7	1	0	0	0	0	0	1	1	0	0	0	0	0	1	1	0	0	0	0	0	0	1
22 tone Magic-10	10	Magic10	1	0	0	0	0	1	1	1	1	0	0	0	0	1	1	1	0	0	0	0	1	1
22 tone Magic-13	13	Magic13	1	0	0	0	1	1	1	1	0	0	0	1	1	1	1	0	0	0	1	1	1	1
22 tone Orwell-5	5	Orwel 5	1	0	0	0	0	1	0	0	0	0	1	0	0	0	0	1	0	0	0	0	0	1
22 tone Orwell-9	9	Orwel 9	1	0	0	1	0	1	0	0	0	1	0	1	0	0	1	0	0	1	0	0	1	0
22 tone Orwell-13	13	Orwel13	1	1	0	1	0	1	1	0	1	0	1	1	0	1	0	1	1	0	1	0	1	0
22 tone SuperPythagorean	12	SuPytha	1	1	0	0	1	1	1	0	0	1	1	0	0	1	1	0	0	1	1	0	0	0
22 tone Miller's Porcupine-7 Major	7	MillMPo	1	0	0	1	0	0	0	1	0	0	1	0	0	1	0	0	1	0	0	1	0	0
22 tone Jones's Porcupine-8	8	JonesPo	1	0	0	1	0	0	0	1	1	0	0	1	0	0	1	0	0	1	0	0	1	0
Alternate Proper Decatonic	10	AltProD	1	0	0	1	1	0	0	1	0	1	0	1	0	1	0	0	1	0	1	0	1	0
Exotic Symmetrical Decatonic	10	ExotSym	1	0	1	0	1	0	0	1	1	0	0	1	0	1	0	1	0	0	1	1	0	0
Standard Pentachordal Major	10	StaPenM	1	0	1	0	1	0	0	1	0	1	0	1	0	1	0	0	1	0	1	0	1	0
Static Symmetrical Major	10	StcSymM	1	0	1	0	1	0	0	1	0	1	0	1	0	1	0	1	0	0	1	0	1	0
Alternate Pentachordal Major	10	AltPenM	1	0	1	0	0	1	0	1	0	1	0	1	0	1	0	1	0	0	1	0	1	0
Dynamic Symmetrical Major	10	DynSymM	1	0	1	0	0	1	0	1	0	1	0	1	0	1	0	0	1	0	1	0	1	0
Static Symmetrical Minor	10	StaSymm	1	0	1	0	1	0	1	0	0	1	0	1	0	1	0	1	0	1	0	0	1	0
Alternate Pentachordal Minor	10	AltPenm	1	0	1	0	1	0	1	0	1	0	0	1	0	1	0	1	0	1	0	0	1	0
Dynamic Symmetrical Minor	10	DynSymm	1	0	1	0	1	0	1	0	1	0	0	1	0	1	0	1	0	1	0	1	0	0
Major quasi-equal Heptatonic	7	quHeptM	1	0	0	0	1	0	0	1	0	0	1	0	0	1	0	0	1	0	0	1	0	0
Minor quasi-equal Heptatonic, Miller's Porcupine-7	7	quHeptm	1	0	0	1	0	0	1	0	0	0	1	0	0	1	0	0	1	0	0	1	0	0
Harmonic Whole-Tone	6	HarMWho	1	0	0	0	1	0	0	1	0	0	1	0	0	1	0	0	1	0	0	1	0	0
Nine-Limit Consonant WholeTone	6	NineLim	1	0	0	0	1	0	0	1	0	0	0	1	0	0	1	0	0	1	0	0	1	0
22 tone Blues	6	22Blues	1	0	0	0	0	0	1	0	0	0	1	1	0	0	1	0	0	0	0	0	1	0
22 tone mode of Tamil Matra	7	Tam1Ma	1	0	0	0	1	0	0	0	1	0	0	1	0	0	1	0	0	0	1	0	0	1
Raga Kanakangi	7	raKanaK	1	0	1	0	0	1	0	0	0	1	0	0	0	1	0	1	0	0	1	0	0	0
Raga Ramkali	8	raRamaK	1	1	0	0	0	0	0	1	0	1	1	0	0	1	1	0	0	0	0	0	1	0
Raga Kharaharapriya, Bhimpalasi	7	raKhaRa	1	0	0	0	1	0	1	0	0	0	1	0	0	0	1	0	0	0	1	0	0	0
Twenty-two tone Natural Minor, Darbari Kanada, Gandhaara Grama (Damodara), Raga Darbari, Darbari Kanada	7	raDarba	1	0	0	0	1	0	1	0	0	0	1	0	0	0	1	0	0	0	0	1	0	0
Raga Vibhas (marva)	5	raVibha	1	1	0	0	0	0	0	1	0	0	0	0	0	1	0	0	0	1	0	0	0	0
Raga Saveri	5	raSaver	1	0	1	0	0	0	0	0	0	0	1	0	0	0	1	1	0	0	0	0	0	0

Table 26: 24-EDO and other 24-tone-per-octave temperaments.

description	t/oct	tone	cents																							
			0	50	100	150	200	250	300	350	400	450	500	550	600	650	700	750	800	850	900	950	1000	1050	1100	1150
Chromatic	24	Chroma	1	1	1	1	1	1	1	1	1	1	1	1	1	1	1	1	1	1	1	1	1	1	1	
Enharmonic Mixolydian	7	en Mixo	1	1	1	0	0	0	0	0	0	0	0	0	0	0	0	0	0	0	0	0	0	0	0	
Enharmonic Lydian	7	en Lydi	1	1	0	0	0	0	0	0	0	0	1	1	1	0	0	0	0	0	0	0	1	0	0	
Enharmonic Phrygian	7	en Phry	1	0	0	0	0	0	0	0	0	1	1	1	0	0	0	0	0	0	1	0	0	0	1	
Enharmonic Dorian	7	en Dori	1	1	1	0	0	0	0	0	0	0	1	0	0	0	0	1	1	1	0	0	0	0	0	
Enharmonic Hypolydian	7	enHLydi	1	1	0	0	0	0	0	0	0	1	0	0	0	1	1	1	0	0	0	0	0	0	1	
Enharmonic Hypophrygian	7	enHPhry	1	0	0	0	0	0	0	0	1	0	0	0	1	1	1	0	0	0	0	0	0	1	1	
Enharmonic Hypodorian	7	enHDori	1	0	0	0	1	1	1	0	0	0	0	0	0	0	0	1	1	1	0	0	0	0	0	
Soft Diatonic Mixolydian	7	sd Mixo	1	0	1	0	0	1	0	0	0	0	1	0	1	0	0	1	0	0	0	1	0	0	0	
Soft Diatonic Lydian	7	sd Lydi	1	0	0	1	0	0	0	0	1	0	1	0	0	0	1	0	0	0	1	0	0	0	1	
Soft Diatonic Phrygian	7	sd Phry	1	0	0	0	0	1	0	0	1	0	0	0	0	0	1	0	0	0	1	0	0	1	0	
Soft Diatonic Dorian	7	sd Dori	1	0	1	0	0	1	0	0	0	0	1	0	0	0	1	0	0	1	0	0	1	0	0	
Soft Diatonic Hypolydian	7	sdHLydi	1	0	0	1	0	0	0	0	1	0	0	0	1	0	0	1	0	0	1	0	0	0	1	
Soft Diatonic Hypophrygian	7	sdHPhry	1	0	0	0	0	1	0	0	0	1	0	1	0	0	1	0	0	0	1	0	1	0	0	
Soft Diatonic Hypodorian	7	sdHDori	1	0	0	0	1	0	1	0	0	1	0	0	0	0	1	0	1	0	0	1	0	0	0	
Neutral Diatonic Mixolydian, Maqam Ouchairan-Hussaini, Bayatan	7	nd Mixo	1	0	0	1	0	0	1	0	0	0	1	0	0	1	0	0	1	0	0	1	0	0	0	
Neutral Diatonic Lydian, Dastgah-e Sehghah	7	nd Lydi	1	0	0	1	0	0	0	1	0	0	1	0	0	1	0	0	1	0	0	1	0	0	0	
Neutral Diatonic Phrygian, Arabic Diatonic, Maqam Rast, Quasi-equal Heptatonic	7	nd Phry	1	0	0	0	1	0	0	1	0	0	1	0	0	0	1	0	0	0	1	0	0	1	0	
Neutral Diatonic Dorian, Maqam Hussaini, Ushaq	7	nd Dori	1	0	0	1	0	0	1	0	0	0	0	1	0	0	0	1	0	0	1	0	0	1	0	
Neutral Diatonic Hypolydian, Maqam Sikah (Segah)	7	ndHLydi	1	0	0	1	0	0	0	1	0	0	0	1	0	0	1	0	0	1	0	0	1	0	0	
Neutral Diatonic Hypophrygian	7	ndHPhry	1	0	0	0	1	0	0	0	1	0	0	1	0	0	1	0	0	1	0	0	1	0	0	
Neutral Diatonic Hypodorian, Miha'il Musaqa's mode: Egypt, Dastgah-e Sehghah, Maqam Nairuz	7	ndHDori	1	0	0	0	1	0	0	1	0	0	1	0	0	0	1	0	0	1	0	0	1	0	0	
Diatonic + Enharmonic Diesis Mixolydian	7	dd Mixo	1	1	0	0	0	0	1	0	0	0	1	1	0	0	0	0	1	0	0	0	1	0	0	
Diatonic + Enharmonic Diesis Lydian	7	dd Lydi	1	0	0	0	0	1	0	0	0	1	1	0	0	0	0	1	0	0	0	1	0	0	1	
Diatonic + Enharmonic Diesis Phrygian	7	dd Phry	1	0	0	0	1	1	0	0	0	0	1	0	0	0	1	0	0	0	1	1	0	0	0	
Diatonic + Enharmonic Diesis Dorian	7	dd Dori	1	1	0	0	0	0	1	0	0	0	1	0	0	0	1	1	0	0	0	0	1	0	0	
Diatonic + Enharmonic Diesis Hypolydian	7	ddHLydi	1	0	0	0	0	1	0	0	0	1	0	0	0	1	1	0	0	0	0	1	0	0	1	
Diatonic + Enharmonic Diesis Hypophrygian	7	ddHPhry	1	0	0	0	1	0	0	0	1	1	0	0	0	1	0	0	0	1	1	0	0	0	0	
Diatonic + Enharmonic Diesis Hypodorian	7	ddHDori	1	0	0	0	1	1	0	0	0	0	1	0	0	0	1	1	0	0	0	0	1	0	0	
Chromatic/Enharmonic Mixolydian	7	ce Mixo	1	1	0	0	1	0	0	0	0	0	1	1	0	0	1	0	0	0	0	0	1	0	0	
Chromatic/Enharmonic Lydian	7	ce Lydi	1	0	0	1	0	0	0	0	0	1	1	0	0	0	1	0	0	0	0	1	0	0	1	
Chromatic/Enharmonic Phrygian	7	ce Phry	1	0	0	0	0	1	1	0	0	0	1	0	0	0	0	1	0	0	0	0	1	1	0	
Chromatic/Enharmonic Dorian	7	ce Dori	1	1	0	0	1	0	0	0	0	0	1	0	0	0	1	1	0	0	1	0	0	0	0	
Chromatic/Enharmonic Hypolydian	7	ceHLydi	1	0	0	1	0	0	0	0	0	1	0	0	0	1	1	0	0	1	0	0	0	0	1	
Chromatic/Enharmonic Hypophrygian	7	ceHPhry	1	0	0	0	0	1	0	0	0	1	1	0	0	1	0	0	0	0	0	0	1	1	0	
Chromatic/Enharmonic Hypodorian	7	ceHDori	1	0	0	0	1	1	0	0	0	1	0	0	0	0	1	1	0	0	1	0	0	0	0	
Neutral Mixolydian, Iced Blizzard	7	ne Mixo	1	0	0	1	0	0	0	1	0	0	0	1	0	0	1	0	0	1	0	0	1	0	0	
Neutral Lydian, Iced Major	7	ne Lydi	1	0	0	0	1	0	0	1	0	0	1	0	0	0	1	0	0	1	0	0	1	0	0	
Neutral Phrygian, Iced Locrian	7	ne Phry	1	0	0	1	0	0	1	0	0	0	1	0	0	1	0	0	0	1	0	0	1	0	0	
Neutral Dorian, Iced Fridgian, Misaelides 2nd Byzantine mode, Maqam Sikah Baladi, Maqamic-7	7	ne Dori	1	0	0	1	0	0	0	1	0	0	1	0	0	0	1	0	0	1	0	0	1	0	0	
Neutral Hypolydian, Iced Lydian, Mohajira-7	7	neHLydi	1	0	0	0	1	0	0	1	0	0	0	1	0	0	1	0	0	1	0	0	1	0	0	
Neutral Hypophrygian, Iced Mixolydian	7	neHPhry	1	0	0	1	0	0	0	1	0	0	1	0	0	0	1	0	0	1	0	0	1	0	0	
Neutral Hypodorian, Iced Dark Lydian	7	neHDori	1	0	0	0	1	0	0	0	1	0	0	0	0	1	0	0	1	0	0	0	1	0	0	
Ratio 1:2 Hemiolic Chromatic Mixolydian	7	rh Mixo	1	1	0	1	0	0	0	0	0	0	1	1	0	1	0	0	0	0	0	0	1	0	0	
Ratio 1:2 Hemiolic Chromatic Lydian	7	rh Lydi	1	0	1	0	0	0	0	0	0	1	1	0	1	0	0	0	0	0	0	0	1	0	0	
Ratio 1:2 Hemiolic Chromatic Phrygian	7	rh Phry	1	0	0	0	0	0	0	1	1	0	0	0	0	0	0	1	0	0	0	0	1	1	0	
Ratio 1:2 Hemiolic Chromatic Dorian	7	rh Dori	1	1	0	1	0	0	0	0	0	0	1	0	0	0	1	1	0	1	0	0	0	0	0	
Ratio 1:2 Hemiolic Chromatic Hypolydian	7	rHHLydi	1	0	1	0	0	0	0	0	0	1	0	0	0	1	1	0	1	0	0	0	0	0	1	
Ratio 1:2 Hemiolic Chromatic Hypophrygian	7	rHPhry	1	0	0	0	0	0	0	1	0	0	0	1	1	0	1	0	0	0	0	0	1	1	0	
Ratio 1:2 Hemiolic Chromatic Hypodorian	7	rHHDori	1	0	0	0	1	1	0	1	0	0	0	0	0	0	1	1	0	1	0	1	0	0	0	
Anchihoye: Ethiopia	5	Ethiopi	1	0	1	0	0	0	0	0	0	0	1	0	0	1	0	0	0	0	0	1	0	0	0	
Spondeion	5	Spondei	1	0	0	1	0	0	0	0	0	0	0	1	0	0	0	1	0	0	0	1	0	0	0	
Godzilla-5	5	Godzill	1	0	0	0	1	0	0	0	0	0	1	0	0	0	0	1	0	0	0	0	1	0	0	
Quasi-equal Pentatonic, Semaphore-5	5	quasiPe	1	0	0	0	0	1	0	0	0	0	0	1	0	0	0	1	0	0	0	0	1	0	0	
de Vries 5-tone	5	deVrie5	1	0	0	0	0	0	0	0	0	0	1	0	1	0	1	0	0	0	0	0	0	0	1	
Spondeiakos	6	Spondeko	1	1	1	0	0	0	0	0	0	0	0	1	0	0	0	1	0	1	0	0	0	0	0	
Maqam Nawa	7	maq Nawa	1	0	1	0	0	0	1	0	0	0	0	1	0	0	0	1	0	0	0	1	0	0	0	
Second plagal Byzantine Liturgical mode	7	Liturgi	1	0	1	0	0	0	0	0	0	0	1	1	0	0	0	1	0	1	0	0	0	0	1	
Maqam Higaz-kar	7	maqHigaz	1	0	1	0	0	0	0	1	0	0	1	0	0	0	1	0	1	0	0	0	0	1	0	
Maqam 'Ushshaq Turki, Urfa, Isfahan, Dastgah-e Shur	7	maqUshsh	1	0	0	1	0	0	1	0	0	0	1	0	0	0	1	0	1	0	0	0	1	0	0	
Maqam Nahfat	7	maqNahfa	1	0	0	1	0	0	1	0	0	0	1	0	0	0	1	0	0	0	1	0	0	1	0	
Maqam Saba	7	maq Saba	1	0	0	1	0	0	0	1	0	1	0	0	0	0	1	0	1	0	0	0	1	0	0	
Maqam Sabr Jaddid	7	maqSabrJ	1	0	0	1	0	0	1	0	0	1	0	0	0	0	1	0	1	0	0	0	0	1	0	
Maqam Qarjighar, Bayati Shuri	7	maqQarji	1	0	0	1	0	0	1	0	0	0	1	0	1	0	0	0	0	0	0	1	0	1	0	
Maqam Hizam (Huzzam, El Houzam), Rahat al Arouah	7	maqHizam	1	0	0	1	0	0	0	1	0	1	0	0	0	0	1	0	1	0	0	0	1	0	0	
Maqam Su'ar, Naghmeh Abuata, Naghmeh Afshari	7	maqSu'ar	1	0	0	1	0	0	0	1	0	0	0	1	0	0	1	0	0	0	1	0	0	1	0	
Dastgah-e Homayun	7	DastHom	1	0	0	1	0	0	0	0	1	0	1	0	0	0	1	0	1	0	0	0	1	0	0	
Dastgah-e Chahargah, Athanasopoulos' Byzantine Liturgical Chromatic,	7	D																								

13 CHANGE LOG

This section contains the list of firmware updates that required additions or modifications to the manual.

V. 155

Fixed an issue that prevented the proper loading of the Variation parameters on CV A and B channels.

Fixed an issue that prevented gate ratchets (“repeats”) to work properly when combined with stage shift.

Fixed an issue that prevented the update of the “see pattern” value on the Dashboard.

Fixed an issue that prevents **M** to display properly on the Dashboard when a channel is muted.

Fixed an issue that prevented the correct visualization of the Pitch voltages on the Dashboard whenever fine-tuned by semitone cents.

Improved the compensation algorithm for potential CV input crosstalk. It may be necessary to recalibrate the ADC after installing the new firmware (see § 10.2.1).

Improved the behavior of the external CV inputs when switching between the CV modulation sources.

Fixed an issue that prevented the root shift parameter to be properly saved and recalled.

Added the decimal BPM feature (see § 3.2.1)

Added the Voltage-Controlled Pattern Recall feature (See § 7.3.8).

V. 152

Extended the Store Pattern functionality to the *Length* parameter. Now USTA stores all the channels of the pattern, not only the one selected.

Changed the shortcut for the channel Hold function: hold SET ALL and the desired channel – *CV A*, *CV B*, *Gate A*, or *Gate B*. (The previous combination was to hold ESC and the desired channel.)

Added external PPM (Pulses per Minute) value to the Dashboard to display how many pulses are received in a minute by the external clock input (up to 3000).

Added the capability for the Dashboard to display the currently playing stage in Performance Mode. To activate it, enter the Project Menu, scroll until the Show-InPlay option, and select Yes (by default, it is set to No). When engaged, USTA will use the fourth row of the

Dashboard (which in Edit Pattern mode displays the last edited stage) to display in real-time all the five stage values. This option might slow down the device.

Rearranged the Dashboard design to include the total pattern length (in units).

Added the Mute Channel function: hold ESC and press the desired channel (*CV A*, *CV B*, *Gate A*, or *Gate B*).

Added CW or CCW pattern rotation while editing it: hold the track button and rotate the navigation encoder on the selected pattern. It affects the values of *CV A*, *CV B*, *Length*, *Gate A*, *Gate B*, and the stage colors.

Added the quick initialization of all the track values:

hold the pencil button for 3 seconds in Edit Pattern to initialize to default all the stage values of the selected track:

hold the pencil button for 3 seconds in Edit Song to initialize to default all the song slots of the selected track.

Added infinite stage loop:

set the stage loop length to 0 (now accessible):

disable stage loop and continue the pattern by double-clicking SET ALL.

Added cross-clone layer between *CV A* & *CV B* and *Gate A* & *Gate B*: hold the target layer button and press the corresponding encoder to apply the clone to a specific pattern

Added a new auxiliary gate target: Run. It uses the incoming gate high/gate low signals to start, stop, and reset USTA with external devices. Four possible configurations are possible, named Run 1, Run 2, Run 3, and Run 4. To activate it, enter the Project Menu, scroll until the Aux Target option, and select any of the four modes.

V. 150

Added fast change of first/last pattern settings in Performance Mode on the selected track: hold *Set All* (**B.1**) and push an encoder for the first pattern and another for the last pattern.

Added the cloning of first/last pattern settings, in performance mode, from the selected track to the others, by double-clicking *Shift All* (**B.2**).

Navigating through stages in composition mode updates the stage values on the display across *CV A*, *CV B*, *length*, *Gate A*, and *Gate B*.

14 TECHNICAL DATA

14.1 SPECIFICATIONS

Parameter	Details	Min	Typ	Max	Unit
Size			36		HP
Depth			38		mm
Current Draw	+12 V			260	mA
	-12 V			50	
Recommended warmup time			30		min
Input Details	CV	Impedance		> 90	K Ω
		Resolution		12	bit
		Amplitude steps		~4.15	mV
		Voltage span	-5		10
	Gate	Impedance		>100	K Ω
		Minimum Trigger Amplitude		> 1.5	V
		Minimum Pulse Period	800		
Output Details	CV	Impedance		< 50	Ω
		Resolution		16	bit
		Amplitude steps		~0.26	mV
		Voltage span	-5		10
	Gate	Impedance		< 50	Ω
		Amplitude		10	V

BRENDO

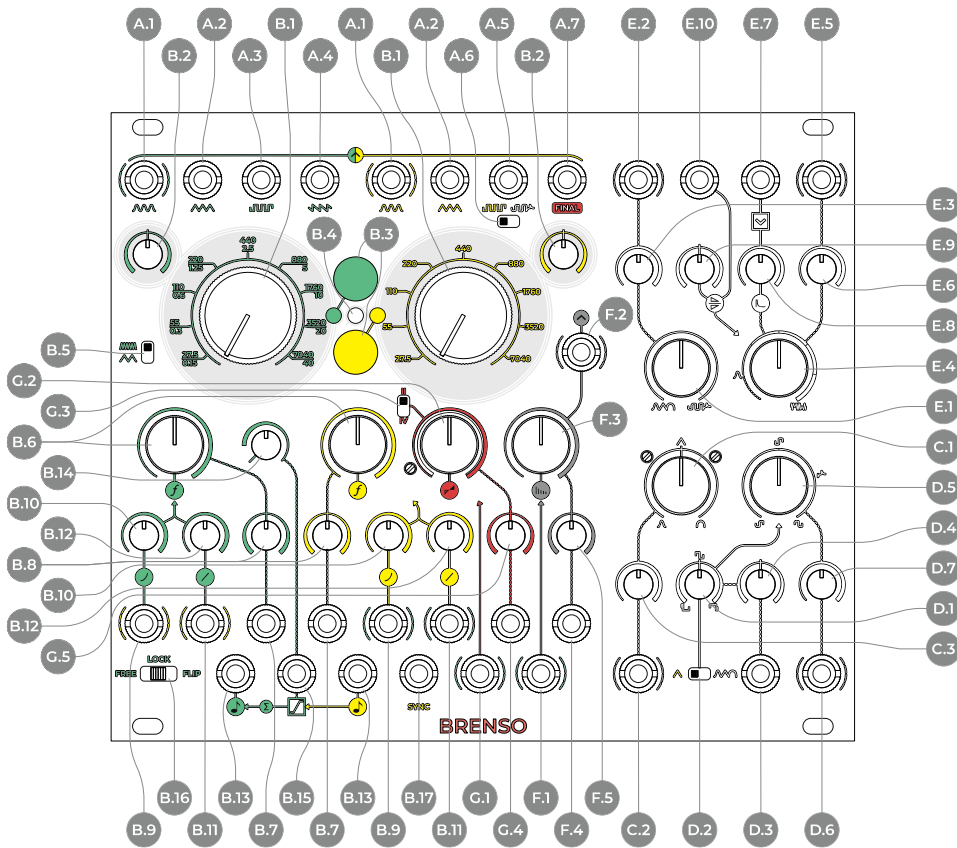

Figure 95: BRENDO interface.

A Outputs

- A.1 Sine Wave Output
- A.2 Triangle Wave Output
- A.3 Square Wave Output
- A.4 Sawtooth Wave Output
- A.5 Square/Shaped Pulse Output
- A.6 Square/Shaped Pulse Switch
- A.7 Final Output

B Frequencies

- B.1 Coarse Frequency
- B.2 Fine Frequency
- B.3 Coarse Frequency Lock
- B.4 Phase Relationship LED
- B.5 Frequency Scale Switch
- B.6 Frequency Modulation (FM) Deviation
- B.7 FM Deviation CV Input
- B.8 FM Deviation CV Attenuverter
- B.9 Exponential FM Input
- B.10 Exponential FM Attenuator
- B.11 Linear Through-Zero FM Input
- B.12 Linear TZFM Attenuator

B.13 V/Oct Input

- B.14 V/oct Integrator Level
- B.15 V/oct Integrator CV Input
- B.16 Sync Switch
- B.17 Sync Input

C Triangle Shaper

- C.1 Triangle Shaper
- C.2 Triangle Shaper CV Input
- C.3 Triangle Shaper CV Attenuator

D Pulse Shaper

- D.1 Pulse Width
- D.2 Pulse-Width Modulation (PWM) Source
- D.3 PWM CV Input
- D.4 PWM CV Attenuverter
- D.5 Pulse Shaper
- D.6 Pulse Shaper CV Input
- D.7 Pulse Shaper CV Attenuator

E Wavefolder

- E.1 Wavefolder Source
- E.2 Wavefolder Source CV Input
- E.3 Wavefolder Source Attenuator

E.4 Wavefolder

- E.5 Wavefolder CV Input
- E.6 Wavefolder Attenuator
- E.7 Wavefolder Ping Input
- E.8 Wavefolder Ping Decay
- E.9 Wavefolder Symmetry
- E.10 Wavefolder Symmetry CV Input

F Modulation Bus

- F.1 Modulation Bus Input
- F.2 Modulation Bus Output
- F.3 Modulation Bus Level
- F.4 Modulation Bus Level CV Input
- F.5 Modulation Bus Level CV Attenuverter

G Amplitude

- G.1 Amplitude Modulation/Ring Modulation (AM/RM) Input
- G.2 AM/RM
- G.3 AM/RM Switch
- G.4 AM/RM CV Input
- G.5 AM/RM CV Attenuverter

1 PHILOSOPHY, DESIGN AND SIGNAL FLOW

BRENZO is Frap Tools' primary analog source of articulated audio waveforms whose degree of entanglement can be precisely set by the musician.

Its concept developed from a reflection on the very meaning of the word 'complex', often used to describe this kind of oscillator after the famous Buchla 259 definition. Complex comes from the Latin verb *plector*, literally meaning 'to braid', or 'to weave.' The purpose of BRENZO is to update the usual approach to 'complex oscillators' by offering many threads to be woven together, rather than a pre-defined plait of controls and waveforms: this to improve clarity, manageability, and to offer more sonic options to the artist.

We designed a unique signal flow from scratch to expand the modulation routing and offer the musician more access to the crucial parts of the circuit.

BRENZO's architecture consists of three main parts: two oscillators, which can modulate each other's frequency, a timbre modulation section, dedicated to waveshaping, PWM, and wavefolding, and a final stage of amplitude modulation. These sections will be described in the next chapters of this manual: Frequency, Timbre, and Amplitude.

2 FREQUENCY

BRENZO generates sounds with two oscillators, whose pitch can be independently regulated. Their frequencies can modulate each other (linearly and exponentially – the linear FM is Thru-Zero), or they can be synced (with Flip Sync or Lock).

2.1 OSCILLATORS

The two sound sources are analog, triangle-core oscillators with excellent stability and tracking. The oscillators are labeled with green and yellow graphics on the front panel, respectively.

Each oscillator features four outputs for different wave shapes. The output jacks are located at the top of the front panel. The green oscillator's outputs are, from left to right: sine (A.1), triangle (A.2), square (A.3), and sawtooth (A.4); the yellow ones are sine (A.1), triangle (A.2), square/shaped square (A.5), plus a *Final* jack socket (A.7) that outputs the sine and/or the Shaped Square after their processing through the *Timbre* and *AM* sections.

2.1.1 Fine and Coarse Tuning

The two largest knobs of the front panel (B.1) are the main control for the two oscillators' *Coarse* frequency. Their range goes from ~27.5Hz to ~7040Hz, as displayed by the graphics.

The *Fine Frequency* knob at the top left of the green oscillator and the top right of the yellow one (B.2) finely adjusts the frequency by adding or subtracting >1 semitone.

The green oscillator can work at sub-audio rates as well, through the *Frequency Scale* switch (B.5). The graphics around the main knob display the LFO frequency range below the audio-rate one: when set in 'Low' scale, the green oscillator goes from ~0.15Hz to ~40Hz, ~176 times slower.



Practice the green LFO with these techniques and ideas:

[Voltage-Controlled LFO](#)

[Spectral LFO](#)

[Study for BRENZO and FALISTR! #1](#)

[Self-Pinging BRENZO](#)

Please note that the oscillators are trimmed to match as close as possible the usage at audio rate: a consequence of this is that the green oscillator may not perfectly match the graphics when used as LFO due to components tolerance.

A red LED (B.4) visually displays the acoustic beats generated by the two oscillators' frequencies.

2.1.2 Coarse Frequency Lock

Sometimes the frequency knobs can be endlessly tweaked in a creative way during the performance, but some other times, they just need to do what they were originally designed for: tuning an oscillator before the performance, and nothing more. However, especially in crowded patches, the Frequency knob of an oscillator can be hit by mistake, causing an unwanted detune and jeopardizing the whole performance – especially when more than one oscillator is playing polyphonic melodies!

To avoid this unfortunate circumstance, we designed a digital implementation that can be engaged to prevent accidental twists of the knobs from detuning the oscillators: the *Coarse Frequency Lock*.

It consists of two buttons (B.3), one per oscillator, that, when pushed, digitally sample and hold the voltage of the *Coarse Frequency* knob (B.1), thus keeping the oscillator's frequency steady. The two buttons are equipped with an LED: when the circuit is engaged, they will light up green or yellow, respectively. From this moment on, the *Coarse Frequency* knob will no longer change the frequency when moved, and the oscillator's pitch will be changed only through external CV or internal frequency modulation. To restore the knob's function, push the button again: if the Coarse knob has changed position in the meantime, the oscillator's coarse frequency will be set accordingly.

Please note that the *Fine Frequency* knob (B.2) is not affected by the *Frequency Lock*, and it will always be available

in case a little adjustment is needed (for example, to compensate small detuning in extreme climatic situations).

Please note that the Frequency Lock offers a way to avoid unintended touches: you still need to warm up your BRENDO as for any other module before using it.

2.1.3 V/oct and Integrator

The frequency of each oscillator can be externally controlled through dedicated *V/oct* inputs (B.13): an external voltage patched to these inputs will offset the frequency set by the *Coarse* and *Fine Frequency* knobs (B.1 and B.2).

Excellent tracking is guaranteed over more than 6 octaves: this feature provides not only good intonation for particularly spread melodic lines but also a more precise ratio between the two oscillators, which translates into richer and better harmonics when any modulation between them is engaged, especially frequency modulation, which will be discussed in the next chapter.

The two oscillators can be independently controlled with different voltages. However, it is also possible to apply the same CV to both oscillators by patching it to the yellow *V/oct* input and routing it to the green oscillator through the *V/oct Integrator* (B.14), without further patching.

This circuit applies the same CV patched into the yellow CV input to the green oscillator after a linear integration, whose amount is set by the knob position (B.14).

When the *Integrator* knob is at its leftmost position, the green oscillator is not affected by the yellow CV, because it would take an infinite time to reach the target voltage. When the integrator knob is at its rightmost position, the exact same voltage offset of the yellow oscillator is applied to the green one, with a very fast integration. When the knob is set to any other position, a time lag, similar to a glide effect, is applied to the voltage routed to the green oscillator: on the left, the glide effect will be longer, and it will be increasingly short as the knob is rotated clockwise. Please remember that the CV is always the same: the only difference is the time required for the green oscillator to reach the value.

It is possible to combine the voltage routed through the *V/oct Integrator* with another offset applied to the green *V/oct* input: for example, the two oscillators can be used in unison and controlled with the same CV through the integrator, while an $n+1$ voltage coming from SAPÉL is patched to the green *V/oct Input* to randomly shift the green oscillator one or more octaves higher.

Furthermore, it is also possible to modulate the integration time with an external CV through the *V/oct Integrator CV Input* (B.15): in this case, any external voltage will be summed to or subtracted from the current position of the knob.



Practice BRENDO's integrator with these techniques:
[Integrator #1](#)
[Integrator #2](#)

2.2 FREQUENCY MODULATION

The two oscillators of the BRENDO can be frequency-modulated, even at an audio rate. Such modulation can be linear or exponential (or both at the same time). You can use external sources to modulate the oscillators' frequency, but every oscillator's input is semi-normalled to the other oscillator's sine wave.

You can read more about linear and exponential fm in the *Modular Synthesis: Core Concepts* chapter above, section 10, page 15.

2.2.1 FM Routing

Both oscillators of the BRENDO can work as carrier and modulator at the same time: this means that the green oscillator can modulate the yellow one, which in turn modulates back the green. This technique allows the creation of extremely complex sounds with just two oscillators, whose final spectral content may even reach the realm of noise.

To achieve this result, BRENDO is equipped with two FM buses, one for the yellow and one for the green oscillator (B.7 to B.12). The scope of each bus is to offer explicit modulation routing with advanced capabilities.

Each FM bus has three main controls: the big one is the FM *Deviation* knob (B.6) connected to its *CV Input* (B.7) and *Attenuverter* (B.8), while the other two smaller knobs are the Linear TZFM Attenuator and the Exponential FM attenuator. The Deviation knob sets the overall modulation that is applied to the oscillator, while the two *attenuators* (B.10, B.12) determine the specific amount of *Linear Through-Zero (TZ)* and *Exponential FM*. All the knobs increase the value through a clockwise rotation, starting from the leftmost position, where no modulating signal is routed.

By default, the linear and exponential modulation source of each oscillator is the other one: the green oscillator is thus semi-normalled to the yellow *Linear TZFM* and *Exponential FM* inputs (B.9 and B.11), and vice versa. It is also possible to break the normalled connections and use another signal by patching it to the desired input. In this case, the respective attenuator knob will attenuate the external signal amplitude. It is thus possible to use up to four different modulation sources at the same time.

To produce audible effects, one must set both the *Deviation* knob and either the *Linear TZ* or *Exponential attenuator* to a value higher than zero (the leftmost position).

BRENZO allows you to control the FM deviation, not the Index: the reason is that the deviation is expressed in Hz, so its impact over the carrier's frequency will become exponentially lower as the latter increases. This generates sounds that are rich in harmonics in the low and mid-range, without becoming excessively harsh in the highest range.

This bus design offers two great advantages: on the one hand, it allows combining linear and exponential FM independently per oscillator. On the other, by having independent CV inputs on the two buses, it is possible to control the modulation amount over each oscillator with different sources, thus creating more articulated timbres.



Practice BRENZO's FM with these techniques:
[Linear Through-Zero Frequency Modulation](#)
[TZFM Modulator Sequencing](#)
[Noise Oscillator 1](#)
[FM With Non-Sine Waves](#)
[Snapppppy Expo FM](#)

2.3 SYNC

Syncing refers to a variety of techniques originally developed to improve and stabilize the relative intonation of two or more analog oscillators.

The common ground is that one oscillator ('primary') should be used as a reference to which other oscillators ('secondaries') must be compared and, if different, corrected: different correction techniques translate into different syncing circuits.

It soon became clear, however, that in certain sync circuits, an exaggerated modulation of a secondary oscillator introduced pleasant overtones to the final sound, and these techniques became widely employed in sound synthesis to generate more complex timbres. This is the case with, for example, Hard Sync, which is often implemented in sawtooth-core oscillators. This circuit takes two oscillators, called 'primary' and 'secondary', and forces the secondary's waveform to reset back to 0 at each primary's duty cycle. Modulating the secondary oscillator's frequency will result in a rich sound that changes timbre without changing pitch since the waveform still resets at the primary's rate. The downside of this process is that every time the secondary wave resets and thus drops back to the beginning of the duty cycle, it may produce a sort of unpleasant "spike," which becomes more and more noticeable as the modulation gets deeper.

BRENZO is equipped with two different circuits, which provide different results and are designed to accomplish different tasks: they are called *Lock* and *Flip Sync*. They can be selected through a three-way switch for the green oscillator ([B.16](#)), and via a jumper on the back of the PCB for the yellow oscillator.

2.3.1 Lock

The *Lock* circuit is designed to provide a precise but subtle correction of an oscillator's pitch (the 'secondary') when it is very close to an integer multiple or divisor of another oscillator's frequency (the 'primary'). It is mainly used to compensate for slight tracking variations that may occur when controlling more oscillators with the same V/oct signal.

The *Lock* system uses the primary square wave to slightly change the thresholds of the secondary oscillator's core: it will shift them up when the primary waveform is positive, and down when it is negative. As a result, the secondary oscillator will gently rush and drag to follow the primary's frequency, without resets or abrupt changes in the waveform direction.

Since this circuit is designed to correct very small differences in frequency, we recommend using it mainly when the secondary oscillator is within a semitone from its desired pitch. If the ratio between the two oscillators is not an integer number, some changes in the harmonic spectra may occur.

By default, the green oscillator can be locked to the yellow one by moving the three-way *Sync Switch* ([B.16](#)) to the *Lock* position.

The yellow oscillator does not have any hardwired secondary capability, but it can be synced to an external waveform by patching it to the *Sync Input* ([B.17](#)) and setting the back jumper to *Lock*.

2.3.2 Flip Sync

It has been said that sometimes an extreme modulation of the synced oscillator may be deliberately used to create complex waveforms, as with Hard Sync. BRENZO's triangle cores allow a different technique, typical of this kind of oscillator, called *Flip Sync* (or *Reverse Sync*): instead of forcing the secondary oscillator's waveform back to the beginning at every primary's duty cycle, it reverses the wave direction. This translates into a more mellow tone, which allows creative modulation without hearing the harsh "spikes" made by the secondary oscillator's waveform reset by sawtooth-based Hard Sync.

Flip Sync is activated by moving the *Sync Switch* of the green oscillator's section ([B.16](#)) to its rightmost position: when engaged, the green core will invert its waveform direction at every yellow duty cycle.

As we said above, *Flip Sync* can be activated for the yellow oscillator, too, by placing the jumper on the back of the PCB to the Sync position. In this way, the yellow oscillator will become the secondary of any signal patched to its *Sync Input* ([B.17](#)).

This technique, in contrast to *Lock*, creates dramatic changes in the secondary's waveform and can be used for more expressive and creative purposes. Since it is not phase-based, and since preserving the original waveform is not a priority, there is no preferred frequency range for

setting the secondary oscillator to be synced properly. Of course, a primary frequency higher than the secondary one would result in a change of amplitude, of the secondary since it will not always be possible to reach the full cycle without a change of direction.

describe the role of the green oscillator and the *Modulation Bus*.



Practice BRENDO's Sync options with these techniques:

[Lock & Flip Sync](#)
[Noise Oscillator #2](#)
[Double Flip Sync](#)
[Flip-Flop Flip Sync](#)

3 TIMBRE

So far, we have seen several ways of generating complex timbres by just acting on the oscillators' frequencies, but BRENDO is capable of much more. A whole section is dedicated to modulating the waveforms of the yellow oscillator through a series of circuits. Here is an overview of the signal routing.

- The yellow triangle wave is routed to a waveshaper called *Triangle Shaper* ([C.1](#), [C.2](#), [C.3](#)), which morphs between a sine and a logarithmic wave. The resulting waveform is sent to two destinations: a crossfader called *Source* ([E.1](#), [E.2](#), [E.3](#)), and a comparator for *Pulse-Width Modulation* (PWM – [D.1](#), [D.3](#), [D.4](#)).
- The comparator takes the modulated waveform and derives a pulse wave, which can be modulated; alternatively, the *Pulse-Width Modulation* (PWM) *Source* can be set to be the pure triangle wave of the yellow oscillator ([D.2](#)).
- The PWM wave is sent to another waveshaper called *Pulse Shaper* ([D.5](#), [D.6](#), [D.7](#)), which emphasizes the high or low harmonics. The resulting signal is sent to two destinations, the *Source* crossfader, and the square wave output of the yellow oscillator. A *switch* ([A.6](#)) below the jack socket ([A.5](#)) selects the output source: pure square wave, or shaped wave.
- The *Sources* crossfader ([E.1](#), [E.2](#), [E.3](#)) receives signals from the *Triangle Shaper* and the *Pulse Shaper* and blends them. The result is fed into a *Wavefolder* ([E.4](#) to [E.10](#)).
- The *Wavefolder* further processes the sound, and its output is sent to another crossfader for amplitude modulation (see below, § 44.1) before being routed to the Final output ([A.7](#)).

All the aforementioned waveshaping techniques are performed over the yellow oscillator's waveforms, and their amount can be modulated (even at audio rate) by the green oscillator's sine wave, through a circuit called *Modulation Bus* ([E.1](#) to [E.5](#)). The following paragraphs will describe the modulation circuits, and the last one will

3.1 TRIANGLE SHAPER

The first waveform modulation circuit is the *Triangle Shaper* (C.1). It can be seen as a three-way mixer that blends three waveforms: a sine wave (leftmost position), an almost-pure triangle wave (noon), and a logarithmic waveform. (Both the sine and the log are generated by shaping the triangle wave, hence its name.)

It is possible to control this parameter, even at audio rate, by patching an external signal to the *CV input* (C.2). An *Attenuator* (C.3) allows for precise scaling of the incoming signal. By default, the modulation input is semi-normally to the *Modulation Bus* output (F.2).

The signal coming from this circuit is then routed to the *Source* crossfader (E.1) and then possibly to the *Wavefolder* (E.4), which can be heard through the final output (more on this below, § 3.3).



Check out the Triangle Shaper in this technique: [Triangle Shaper](#)

3.2 PULSE SHAPER

The other waveshaping circuit consists of two sections strictly connected: first, a comparator generating a pulse wave capable of pulse-width modulation (PWM), and then another waveshaper to which the PWM output is routed.



Check out the Pulse Shaper in this technique: [Pulse Shaper](#)

3.2.1 Pulse-Width Modulation (PWM)

The PWM circuit generates a pulse wave through a comparator. This technique requires a waveform and a voltage value used as a reference. The comparator, as the name suggests, compares the waveform to the reference voltage: every time the waveform is equal to or higher than the reference voltage, the output voltage will be high; conversely, every time the waveform is lower than the reference voltage, the output will be low. The alternation of high and low voltages produces a pulse waveform, whose width depends, on the one hand, on the initial waveform fed into the comparator, and on the other, on the value of the reference voltage.

A classic example of pulse-width modulation is achieved by using a fixed triangle waveform and varying the comparator threshold: this operation changes the reference voltage and thus the point where the output voltages are high and low, but without affecting the duty cycle, i.e., the frequency.

It has been said that both the elements of the comparator (the waveform and the reference voltage) play a fundamental role in pulse wave generation: the two main controls of BRENSO's PWM circuit affect exactly these two parameters.

The two-way *Source* switch at the bottom (D.2) selects the source to be fed into the comparator: when it is set on the left, the source is the yellow triangle wave, straight from the oscillator's core, and the result is a classic pulse wave; when it is set on the right, the source is the wave generated by the *Triangle Shaper* according to its knob position (it can be a sine, a logarithmic wave or everything in between).

The *Pulse Width* knob (D.1) sets the comparator threshold and thus varies the pulse wave, or the ratio between the positive and negative side of the waveform (also called 'symmetry'). When the source is the triangle wave, and the knob is centered, the ratio will be ~50%, which translates into an almost perfect square wave. Moving the knob to the left or the right will change this ratio, thus generating a positive or negative asymmetry).

The *CV Input* at the bottom (D.3) accepts any signal to be used to vary the wave symmetry, with a dedicated *Attenuverter* (D.4) to scale or invert it: when the attenuverter is set at noon, no modulation is applied; rotate the knob on the left or right to apply a negative or positive modulation, respectively. Patch any LFO-like signal to the modulation input and adjust the attenuverter to achieve the classic PWM sound.

When the *Triangle Shaper* is used as a source for the comparator, it can produce more complex results: for instance, the pulse wave symmetry can be varied by modulating the wave shape, without changing the comparator threshold. Modulate both the waveshaper and the symmetry control to generate articulated modulations, which are harder to obtain with more conventional PWM circuits.



Practice the PWM with these techniques: [PWM 1](#)
[PWM 2](#)

3.2.2 Waveshaper

The *Pulse Shaper* circuit is BRENSO's second waveshaper. It further shapes the harmonic content of the pulse wave generated by the PWM circuit (§ 3.2.1).

When its main knob (D.5) is at the leftmost position, it emphasizes the lower frequencies; the higher overtones will become increasingly higher until the noon position is reached: at this point, the waveform generated by the PWM circuit is almost purely reproduced. When the knob is rotated past noon, the higher frequencies will be

progressively emphasized, until roughly two o'clock (75% of the knob stroke), where they will have the highest amplitude. From this point onward, the lower frequencies will be emphasized again, but with an inverted phase, until the rightmost position is reached, where the signal is the same as at the leftmost position, but with an inverted phase.

It is possible to control this parameter, even at audio rate, by patching an external signal to the *CV input* (D.6). An *Attenuator* (D.7) allows for precise scaling of the incoming signal. By default, the modulation input is semi-normally to the *Modulation Bus* output (F.2).

The output of the *Pulse Shaper* is routed to two different points of the circuit. First, to the yellow square wave output (A.5), where it can be selected with a dedicated switch (A.6), instead of the regular, core-derived square wave; then, it is sent to the final wavefolding stage.

3.3 WAVEFOLDER

So far, we have described two signal paths: the one of the *Triangle Shaper*, and the one of the PWM through the *Pulse Shaper*. Both are further modulated through a *Wavefolder*.



Practice the Source and Wavefolder parameters with these techniques:
[Source and Wavefolder](#)
[Wavefolder Ratcheting](#)

3.3.1 Sources

The first stage of the wavefolding circuit is the *Source* control. It is essentially a crossfader between the two wave-shaped signals: the one from the *Triangle Shaper* and the other from the PWM through the *Pulse Shaper*.

When its knob (E.1) is set at the leftmost position, only the signal coming from the *Triangle Shaper* is sent to the *Wavefolder*. Rotate the knob clockwise to blend in the signal coming from the *Pulse Shaper*: at noon, the blend will be 50-50. At the rightmost position, however, the signal sent to the waveshaper will not be purely the one coming from the *Pulse Shaper*, but a small amount of the other one will still be audible.

This design choice has been made to improve the tonal characteristics of the folded signal. Because of its nature, any “pure” pulse waveform may produce some irrelevant results when folded, or even some amplitude loss. To prevent this from happening, the *Source* control will always retain some of the triangle-shaped signal, which will dramatically improve the behavior of the wavefolder.

If you want to hear the pure sound of the *Pulse Shaper*, you can always use the *Square/Shaped Pulse Output* (A.5) and set its *Source* switch (A.6) to the leftmost position.

It is possible to control this parameter, even at audio rate, by patching an external signal to the *CV input* (E.2).

An *attenuator* (E.3) allows for precise scaling of the incoming signal. By default, the modulation input is semi-normally to the *Modulation Bus* output (F.2).

3.3.2 Folding

A wavefolder is a circuit that amplifies a waveform beyond a pre-determined threshold: for this reason, it can also be classified as a distortion unit. Once its peaks reach the threshold (both on the positive and negative sides), instead of being clipped, they are “folded” on themselves. When they reach the opposite threshold, they are folded back again, and the cycle repeats, generating as many folds as the circuit design. The result of these folds is an increasing number of overtones that generate a richer sound.

The main control of BRENDO’s wavefolder is the *Wavefolder* knob (E.4). Its range is divided into six layout graphic portions with increasing line thickness, which roughly reflect the number of folds performed by the circuit.

The first section is marked with a dotted line and spans from the leftmost position to the icon of a “clean” waveform. In this range, the knob simply controls the amplitude of the incoming signal, from 0 to unity gain.

Rotating the knob from this point onward will generate more and more folds, until the maximum is reached, at the rightmost position.

It is possible to control this parameter, even at audio rate, by patching an external signal to the *CV input* (E.5). An *Attenuator* (E.6) allows for precise scaling of the incoming signal. By default, the modulation input is semi-normally to the *Modulation Bus Output* (F.2).

3.3.3 Symmetry

A peculiar feature of a wavefolding circuit is that it can be forced to fold the positive half-cycle before the negative one, and vice versa, by adding a voltage bias to the incoming signal. This translates into an unbalanced distortion, which provides different overtone configurations.

This technique can be performed on BRENDO through the *Symmetry* knob (E.9): at noon, the incoming waveform is perfectly balanced. Rotate the knob clockwise to increase the folds of the positive half-cycle, and counterclockwise to increase the folds on the negative half-cycle.

A *CV Input* (E.10) sums any external voltage to the value selected by the knob.



Practice the Symmetry control with this Technique:
[Unbalanced Wavefolding](#)

3.3.4 Ping

In many natural sounds, a higher amplitude sound often contains a higher number of harmonics in the sound spectra. Moreover, many natural instruments have a higher amplitude when they begin to generate a note, which gradually decays over time. The consequence of these two facts is that the timbre of many acoustic musical instruments evolves while a note is played, having richer harmonic content during the attack than during the decay. In other words, the harmonic content is often vaguely proportional to the amplitude of the signal: think, for example, about guitar strings, whose tone changes according to the strength it is plucked with.

This peculiarity contributes to the dynamic range of any musical instrument, and it is often an issue with electronically generated waveforms, whose harmonic content remains the same throughout different amplitudes.

The wavefolder circuit can be very helpful for changing the harmonic content over time and achieving more dynamic results, and, for this reason, BRENSO is equipped with a circuit specifically designed to dynamically change the fold numbers over time by responding to an external impulse.

The *Ping* circuit uses an external trigger patched to its input (E.7) to excite the wavefolder, then integrates it with a nonlinear decay curve. The result is that the folder, once excited, quickly opens the wavefolder circuit above its maximum value, and then gradually closes it to the level set by the *Wavefolder* knob (E.4). The amount of this decay is set through the *Ping Decay* knob (E.8): at its leftmost position, it is extremely fast, while at its rightmost position, it becomes significantly longer.

Remember that the lowest level to which the *Ping* decay ends is set by the *Wavefolder* knob: if it is set to the rightmost position, the effects of the *Ping* will be less noticeable.

The circuit detects any steep rising edge and uses it to excite the wavefolder. It means that triggers are preferred, but any gate signal can be used as well: the *Ping* circuit will behave in the same way, regardless of the gate length.

Theoretically, any steep transition between a low and a high voltage can be used to excite the *Ping*, but practically sometimes using signals different than triggers or gate may cause it not to work as expected.

3.4 TIMBRE MODULATION BUS

The four parameters of this section (*Triangle Shaper*, *Pulse Shaper*, *Source*, and *Wavefolder*) can be controlled both via external CV and through an internal semi-normalized routing called *Modulation Bus*.

The *Modulation Bus* is a multi-target VCA circuit: its input (F.1) is semi-normalled to the green oscillator's sine wave output (A.1), and its output is semi-normalled to the four *CV Inputs* listed above (C.2, D.6, E.2, E.5). Its main

knob (F.3) controls the VCA *Level*, which can also be externally controlled through a *CV input* (F.4) with a dedicated attenuverter (F.5). At its leftmost position, the main knob closes the VCA, and at its rightmost position, it reaches unity gain and outputs a sine wave almost identical to the one coming from the green oscillator's sine output.

At its most basic configuration, the *Modulation Bus* sets the amount of the green sine signal to be sent to the four *Modulation Inputs*: here, it can be independently regulated for each of the four sections of the circuit. For example, you can set the *Level* knob (F.3) to noon, which will route to the *CV Inputs* a sine wave of half the amplitude; then, you can set the *Pulse Shaper Attenuator* (D.7) to a subtle level, and the *Wavefolder CV Attenuator* (E.6) to perform a deeper modulation. This allows you to carefully dose the amount of internal modulation to each of the four parameters.

The main purpose of the *Modulation Bus*, however, is to dynamically control the amount of modulation sent to the four *CV Inputs* at the same time, especially via external CV. For example, you can set the *Level* knob (F.3) fully counter-clockwise to close the VCA, then patch an envelope to the *Level CV Input* (F.4) and adjust its amount through the attenuverter (F.5): in this way, the envelope will control the amount of modulation sent to the four CV inputs, which, in turn, will scale it independently to their destinations.



Practice the Timbre Modulation Bus with these Techniques:
[Timbre Modulation Bus #1](#)
[Timbre Modulation Bus #2](#)
[Timbre Mod VCA and Self Modulation](#)

Further operations can be performed. First, the input semi-normalled connection of the *Modulation Bus* can be broken by patching any signal to the *Input* jack socket (F.1). The new signal is treated in the same way: it is routed to the four destinations, where it can be independently scaled, and it can be further modulated via the *Level CV Input* (F.4).

Then, the *Modulation Bus Output* (F.2) allows you to take any signal processed by the VCA and send it wherever you need in the patch. The most “extreme” configuration of this circuit is as a stand-alone VCA, which can process an external signal, using an external CV, and send the processed signal to a different module, without even affecting any component of the BRENSO.

Remember that the semi-normalled connection is broken only through the inputs: if you patch the *Modulation Bus Output* to any point of your patch, its signal will still be internally routed to the four *CV Inputs* of the *Timbre* section, until a jack is patched into them.



Practice the main Timbre parameters with these Techniques:
[Timbre Sequencing](#)
[Timbre Randomness](#)

4 AMPLITUDE

We have described how BRENDO can generate complex timbres by modulating the frequencies or the waveforms, but there is one additional section: following the signal routing, after the waveshaping and wavefolding sections, a further degree of modulation can be engaged through the *Amplitude Modulation* section.

This section is a two- or four-quadrant linear multiplier very similar in concept and design to the one that can be found in the FALISTRIS module (refer to FALISTRIS's § 3.2 for technical details)

One input of the multiplier is the signal coming from the *Timbre* section, while the other can be set by the musician. By default, the second input is semi-normalled to the green sine wave: patch a cable to this input to break the internal semi-normalled connection.

Both inputs are unattenuated 10 V peak-to-peak bipolar signals: when replacing the second input, you can use any signal you like, but its overall amplitude may lead to different results.

The main control is the Amplitude Modulation/Ring Modulation (*AM/RM*) knob (G.2), which is essentially a crossfader between the signal coming from the *Timbre* section and its amplitude-modulated copy. When the knob is set fully counterclockwise, the signal from the *Final* output will be exactly the one coming from the wavefolder. Rotate it clockwise to blend in the amplitude-modulated signal, until the rightmost position is reached: here, only the signal coming from the four-quadrant multiplier will be heard.

This crossfading can be externally controlled via an external CV, whose input (G.4) features a dedicated attenuverter (G.5) to scale or invert the incoming signal.

4.1 AMPLITUDE MODULATION AND RING MODULATION

Just like in the FALISTRIS, this multiplier can work with two or four quadrants. In simpler terms, while the signal coming from the waveshaper is always bipolar, the modulator (semi-normalled to the green sine wave) can be either unipolar or bipolar. Further down the line, it can be said that the modulating signal can perform either Amplitude Modulation (when unipolar) or Ring Modulation (Bipolar).

The difference with FALISTRIS's Four Quadrant Multiplier is that, while its modulation type changes according to the signal patched in (bipolar for RM, unipolar for AM), here the expected signal is always 10 V peak-to-

peak, which is then internally scaled to perform the two tasks via a dedicated switch (G.3).

At its upper position, the switch scales the modulating signal on the positive side only, thus engaging only two quadrants and performing amplitude modulation. Set it to the lower position to make it bipolar, engage the four quadrants, and perform ring modulation.



Practice the Amplitude section with these Techniques:
[Amplitude Modulation #1](#)
[Amplitude Modulation #2](#)
[BRENDO's Fake VCA](#)

For the differences between AM and RM, please refer to the introductory chapter *Modular Synthesis: Core Concepts*, especially section 8, page 12.

5 TRIMMERS

BRENDO is equipped with 23 trimmers for calibration purposes. Some of them are meant to be operated by Frap Tools only, while others can be used by expert musicians who need to fine-tune certain parameters.

The trimmers are not manual potentiometers, therefore not designed to handle a large number of twists. For this reason, you must be exactly sure about what you want to achieve when you put your hands on a trimmer, and you should limit any trimming operation to the strictly necessary.

5.1 ACCESSIBLE TRIMMERS

There are 17 trimmers that an expert user can access, both on the front panel and on the back of the PCB. They control seven parameters, described in the following paragraphs.

5.1.1 Coarse Frequency

Underneath the two Coarse Frequency Knob, on the front panel, there are two couples of trimmers labeled *m* and *M*. They control the minimum and maximum value of the Coarse Frequency knobs of each oscillator, to make them match as close as possible the frequency scales of the panel label.

5.1.2 Sine Wave Symmetry

Close to the Coarse Frequency Trimmers lie two more couples of trimmers, one per oscillator, labeled + and x: they control the symmetry and gain of the stage that shapes the triangle wave into a sine wave. By default, the sine wave is calibrated to be almost pure, but it may be interesting to alter its shape on purpose to bring in the second harmonic.

5.1.3 Sawtooth Wave Symmetry

At the upper right corner of the back of the PCB, there is a trimmer that regulates the symmetry of the green sawtooth waveform. As for the sine waves, this is factory calibrated to an almost-pure sawtooth, but it can be altered on purpose.

5.1.4 Exponential FM Zero

On the back of the PCB, two trimmers in the lower-right corner control the DC-Offset compensation for the external source of exponential frequency modulation.

5.1.5 Triangle Waveshaper Shape

Two trimmers close to the Triangle Waveshaper knob control the shape of the logarithmic waveform that can be heard when the knob is at the rightmost position. This circuit is borrowed from the FALISTRIS module.

5.1.6 Wavefolder Symmetry

This trimmer is located on the back of the PCB and adjusts the symmetry of the wavefolding circuit, i.e., the number of folds that appear on the positive and negative front of the waveform at a given position of the Wavefolder knob and when the Symmetry knob is at noon.

5.1.7 Four-Quadrant Multiplier

This trimmer controls the symmetry of the amplitude and ring modulations: it is used to make sure that, whenever the modulating signal reaches 0 V, the modulated one is as closest possible as its un-modulated version.

To calibrate the Amplitude Modulation circuit, patch a dummy cable to the second input of the Amplitude Modulation section, set the modulation amount fully clockwise, and trim it to reach the lowest possible amplitude.

5.1.8 Comparator

This circuit prevents the oscillator core from stalling by controlling the direction of the negative front of the

bipolar waveform. The trimmer regulates the position of the threshold below which the triangle wave is detected as negative by the oscillator core.

Due to common factors such as power or ground distribution, it may happen that an oscillator stalls when set at low frequencies and modulated with a carrier with sharp transients. In this case, gently rotate this trimmer (labeled *Core Comp*) counterclockwise with a trim pot screwdriver until the oscillator is heard again. If you have troubles with this operation, contact us at support@frap.tools.

5.2 NON-ACCESSIBLE TRIMMERS

There are six more trimmers that must not be touched for any reason because it will void the module's warranty. They control the crucial parameters of the oscillators and are carefully calibrated by our technicians: if modified, they may cause BRENSO to behave in the wrong way. They are all in couples (one per oscillator core) and located on the back of the PCB.

5.2.1 Gain

This trimmer controls the gain applied to the external CV patched to the V/oct input. The gain circuit provides the right scaling of the external CV before it is routed to the expo converter.

5.2.2 Base

This trimmer regulates the offset that is added to the exponential conversion of the oscillator's control voltages. It prevents the response curve from losing linearity as it gets close to 0, and the oscillator from stalling.

5.2.3 Symmetry

This trimmer regulates the symmetry of the triangle core, from which all the other waveforms are derived.

6 TECHNICAL DATA

6.1 SIMPLE SIGNAL FLOW

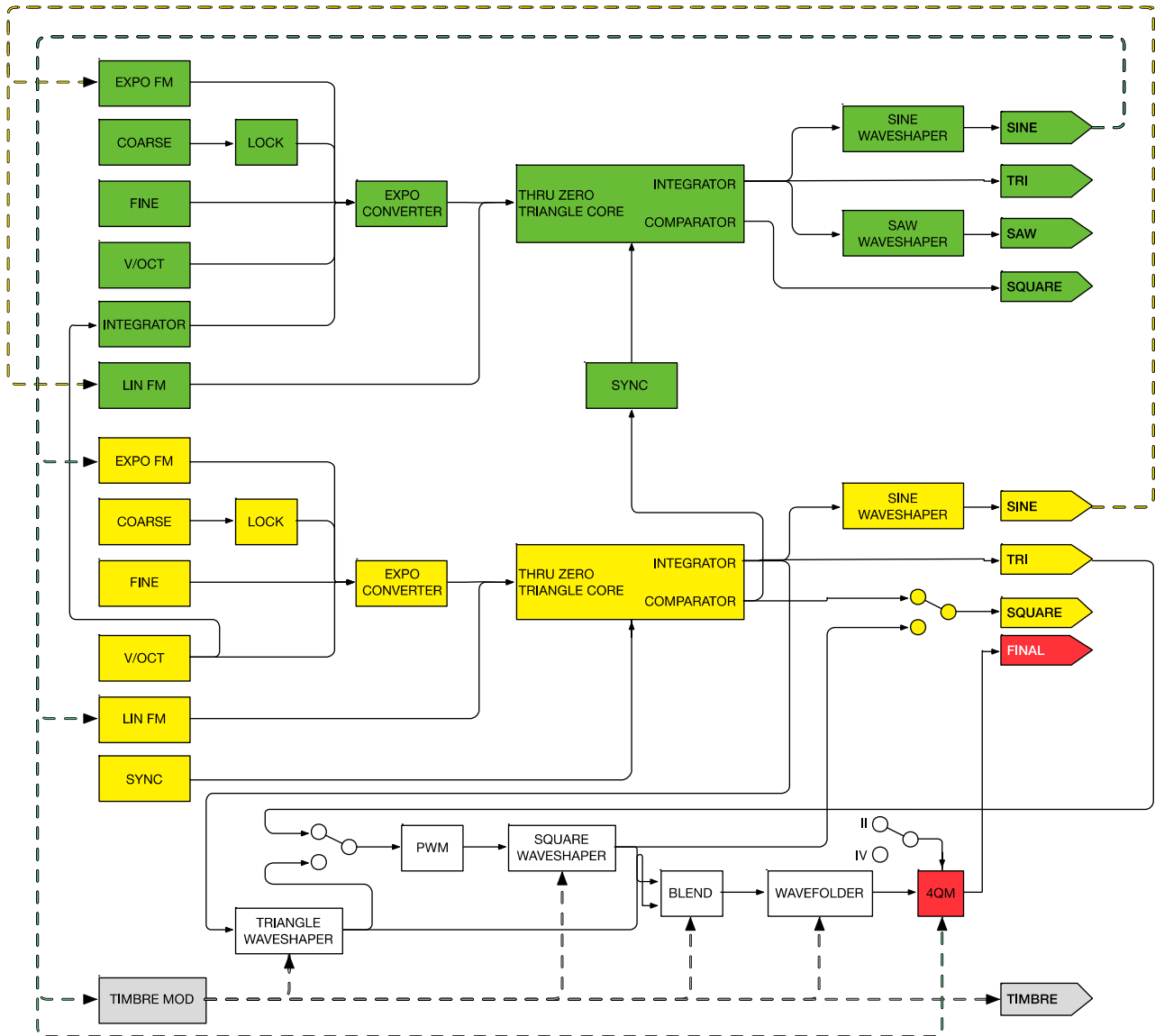

Figure 96: BRENSO's signal flow.

6.2 REVISIONS

Starting from lot no. 200901 we rearranged the board layout to facilitate the calibration procedure in the lab. The functions of the module and its tech specs have not been changed.

6.3 SPECIFICATIONS

Parameter	Details	Min	Typ	Max	Unit
Size			30		HP
Depth			38		mm
Current Draw	+12 V			325	mA
	-12 V			235	
Recommended warmup time			30		min
Input details (1)	V/oct		>90		kΩ
	FM source	Impedance	>30		
	Deviation CV		>90		
	Integrator CV		>40		
			>60		
	Sync		Minimum amplitude	2	
		Suggested amplitude	±5		
	AM CV	Impedance	>40		kΩ
	AM source	Suggested amplitude	>90		
	Timbre Modulation source	Impedance	>40		kΩ
	Timbre modulation CV		>90		
	Triangle Waveshape CV		>60		
	Pulse Waveshaper CV		>60		
	PWM CV		>90		
	Sources CV		>25		
	Wavefolder CV		>60		
	Wavefolder Symmetry CV		>50		
Ping	>90				
Output Details	Audio outputs		Impedance	>100	
		Amplitude (2)	±5		V _{pp}
Oscillators	Knob range	Audio rate	27.5	7040	Hz
		LFO mode	0.15	10	V
			~6.6	25	ms
	Ratio (3)		176:1		
	Tracking (4)		±5		ε
	Fine tuning		>1		st
Core crosstalk			-50		dB
CV input range	FM Deviation	Usable voltages	-10	10	V
		Absolute knob offset	5		
	Integrator	Usable voltages	-10	10	
		Absolute knob offset	7		
	Modulation bus VCA	Usable voltages	-10	10	
		Absolute knob offset	6		
	Source	Usable voltages	-10	10	
		Absolute knob offset	7		
	Wavefolder	Usable voltages	-10	10	
		Absolute knob offset	10		
	Triangle Shaper	Usable voltages	-10	10	
		Absolute knob offset	7		
	Pulse Shaper	Usable voltages	-10	10	
		Absolute knob offset	9		
Comparator threshold	Usable voltages	-10	10		
	Absolute knob offset	4,5			
AM/RM cossfade	Usable voltages	-10	10		
	Absolute knob offset	6			

- (1) All buffered.
- (2) Unloaded.
- (3) Subject to ±3% tolerance.
- (4) Measured at 440 Hz over ±3 octaves.

CUNSA

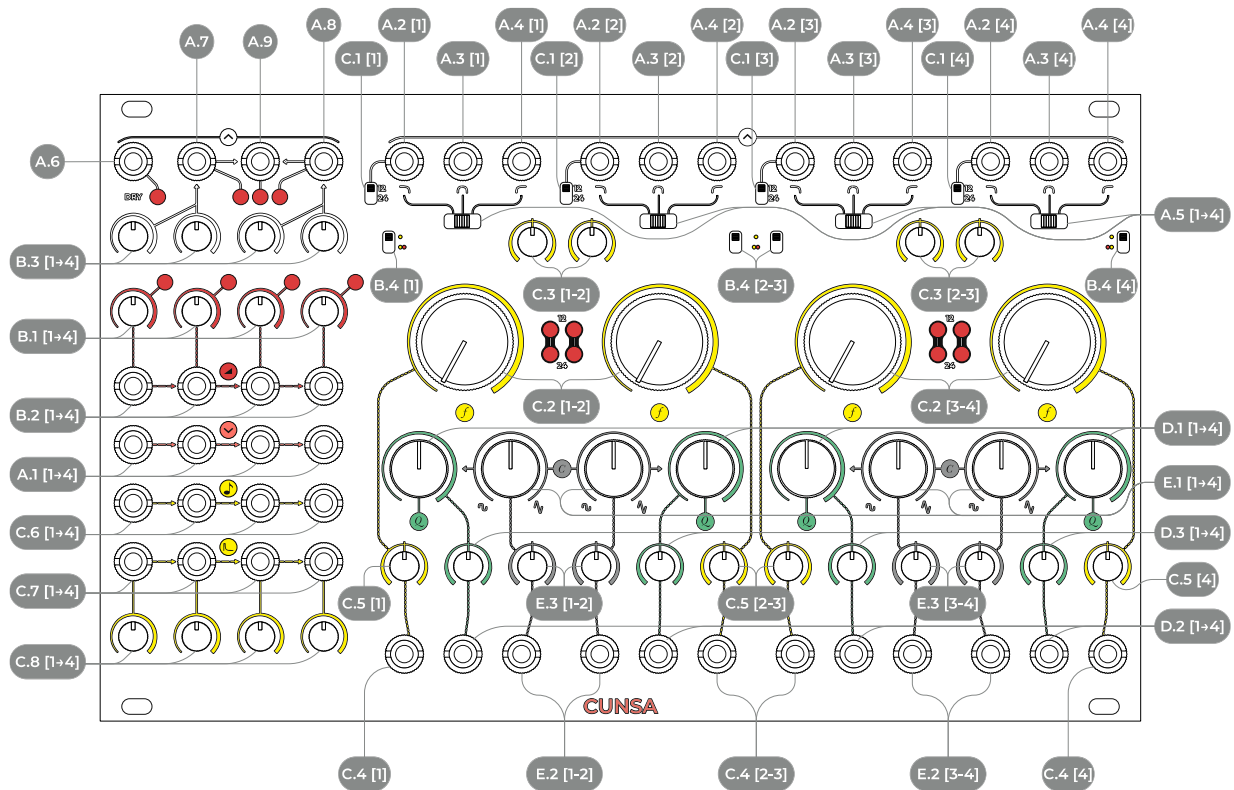

Figure 97: CUNSA interface.

A Audio Inputs and Outputs

- A.1 Audio Inputs 1-4
- A.2 Lowpass Outputs 1-4
- A.3 Bandpass Outputs 1-4
- A.4 Highpass Outputs 1-4
- A.5 Filter Routing Switch 1-4
- A.6 Dry Output
- A.7 1+2 Output
- A.8 3+4 Output
- A.9 All Output

B Amplitude

- B.1 Filter Input VCA level 1-4
- B.2 Filter Input VCA CV 1-4
- B.3 Filter Output Levels 1-4
- B.4 Filter Behavior Switch 1-4

C Cutoff Frequency Controls

- C.1 Lowpass Cutoff Slope
- C.2 Coarse Frequency 1-4
- C.3 Fine Frequency 1-4
- C.4 Frequency CV Inputs 1-4
- C.5 Frequency CV Attenuverters 1-4

C.6 Frequency V/oct Inputs 1-4

- C.7 Frequency Ping Inputs 1-4
- C.8 Frequency Ping Decay 1-4

D Q and Resonance Controls

- D.1 Q 1-4
- D.2 Q CV Input 1-4
- D.3 Q CV Attenuverters 1-4

E Saturation Controls

- E.1 Character 1-4
- E.2 Character CV Input 1-4
- E.3 Character CV Attenuverter 1-4

1 PHILOSOPHY AND DESIGN

CUNSA is a quadruple mono or double stereo pingable multimode resonant filter, saturator, mixer, and oscillator.

It is our sound seasoning tool: it can gently glue together a patch by applying a “final touch,” or it can set it on fire with a ridiculous amount of spice. It’s up to you and your cooking style!

Cunsa consists of four multimode resonant filters with a custom saturation and feedback control that you can use independently or in various combinations thanks to a series of semi-normalled inputs and grouped outputs.

2 INDEPENDENT FILTERING

Let us start by describing how a single filter works.

Each filter has an audio input with gain control and three audio outputs, one for each mode: lowpass, bandpass, and highpass. They all share the same cutoff frequency. Once we patch an audio signal through a filter, its controls will change the sound’s timbre in different ways, according to which of the three outputs you are monitoring. (It is possible to route each output to a mix bus for a linked behavior, on which see § 3).

To filter a signal, patch a cable to the corresponding filter input, for example, the input no. 1. The filtered sound now becomes immediately available at the three filter outputs. The filter performs three main operations:

- Removes part of the sound;
- Emphasizes the cutoff frequency;
- Adds further distortion.

2.1 SETTING THE INPUT GAIN

The first stage is the input gain ([B.1](#)). This knob defines the input signal's amplitude, and it can attenuate it all the way to silence or amplify it above unity gain. Over-amplifying the input signal will saturate the circuit, which can be an interesting effect and will affect the overall timbre of the filter. The input gain knob becomes an attenuator whenever a CV signal is patched to the VCA CV input ([B.2](#)).

Any saturation of the input signal will also affect the dry sound quality when using the *Dry* signal output ([A.6](#)) see § [3.1 below](#).

The sound quality of the saturation depends on the *Character* settings, which can make it smoother or harsher, see § [2.6 below](#).

2.2 SELECTING THE FILTER/COMBO BEHAVIOR

Each filter on the CUNSA has two working modes selectable through the Filter Behavior switch: Filter and Combo.

When set to the upper position (*Filter*), every modulation of the frequency (see § [2.4 below](#)) will be limited to the filtering circuit and will affect only the sound's timbre.

When set to the lower position (*Combo*), the modulation of the cutoff frequency will also affect the input VCA: as the cutoff frequency gets lower, the sounds' amplitude and any possible input saturation will reduce in a non-linear way different than the cutoff reduction.

This behavior might resemble some vactrol-based low-pass filtering designs of the past, where two uncorrelated voltage curves over the filter and the VCA created a natural decay sound. Sending fast timing pulses to such filters created a very organic decay that naturally reduced the amplitude and the harmonic content of the sound like an acoustic instrument would do.

This behavior is especially evident when using CUNSA's Ping circuit, see § [2.4.4 below](#).

Be careful when selecting the Combo behavior! It will affect every control over the cutoff frequency, see § [4.4 below](#).

2.3 CHOOSING THE FILTER TYPE AND SLOPE

Since CUNSA's filter is multimode, it filters the signal you patch to the input in three ways: lowpass, bandpass, and highpass.

To listen to the different filters, simply patch a cable to their corresponding output.

The highpass and bandpass filters have a slope of 12 dB/oct, while the lowpass filter has a selectable slope

of 12 or 24 dB/oct that you can select via the *Slope* switch. ([C.1](#)).

Setting it to 12 will engage the 12 dB/oct behavior, letting more high frequencies pass through.

Setting it to 24 will engage the 24 dB/oct behavior, providing a steeper slope, filtering more high frequencies.

2.4 MODULATING THE CUTOFF FREQUENCY

Each filter on the CUNSA has a variable cutoff frequency, which means that it can seamlessly change the point at which it starts filtering out the spectral content of the input signal.

You can control the cutoff frequency in four ways:

- Through the *Coarse* and *Fine frequency knobs* ([C.2](#) [C.3](#));
- Through the *Frequency CV input* ([C.4](#));
- Through the *V/oct input* ([C.6](#)[C.6](#));
- Through the *Ping* circuit ([C.7](#)).

All these ways converge to the same circuit point and have the same effect: sending a high control voltage or setting the knob to the right will provide a high cutoff frequency, whereas a low voltage or a left knob position will cause a low cutoff frequency.

However, since the filter is multimode, a given cutoff frequency setting will have different effects for each filter.

For example, if we set the cutoff frequency to 200 Hz, the lowpass filter will output a very dark sound, because it will filter every frequency above 200 Hz. However, the same setting will have the opposite effect on the highpass filter output, since that circuit will filter every frequency *below* 200 Hz, and it will thus provide a very bright sound.

So, while changing the cutoff frequency, always remember that the effect on a filter type will be mirrored over another.

2.4.1 The Frequency Knobs

The main way to change the cutoff frequency is the coarse frequency knob ([C.2](#)). Rotate it to the left to reduce the cutoff frequency, and to the right to increase it.

When set to the leftmost position, the filter will reach its lowest cutoff frequency, which is around 10 Hz. With this setting, we can consider the lowpass filter "fully closed" and the highpass filter "fully open".

When the knob is set to the rightmost position, the filter will reach its highest cutoff frequency, around 25 KHz. Predictably, now the lowpass filter will be completely open and the highpass filter completely closed.

Since the bandpass filter combines both behaviors, it can never be "open". The cutoff frequency, here, roughly defines the middle frequency that passes through the filter, and every other frequency above and below it will be symmetrically filtered out.

Rotating the filter knob with any behavior creates the famous "filter sweep" effect.

On top of that, the CUNSA filter also features a Fine frequency knob (C.3), which allows more precise tuning of the filter frequency. This knob is especially useful when we want to tune the filter to a specific frequency, for example, an overtone of the signal we're filtering.

It is also useful when we want to use the filter as a sine wave oscillator, see § 2.6.1 below.

2.4.2 The Frequency CV input.

This input (C.4) allows you to control the filter frequency via CV. It accepts unipolar and bipolar voltages from -10 to +10 V and features attenuverters to scale or invert the control voltage.

The most common application is probably an envelope triggered by a CV/gate sequencer or controller that opens and closes the filter together with every note. This is a rudimentary but very effective way of changing the sound spectrum over time and emulating the behavior of acoustic instruments.

Another common CV for modulating the filter frequency is a copy of the V/oct signal that we use to articulate our melodies. By using the attenuverter, it is possible to establish a precise correspondence between the filter cutoff and the note's pitch.

For example, by inverting the V/oct signal you can make the lower notes of your melody sound brighter, and the higher ones sound duller. If you want a 1:1 correspondence between your oscillator's frequency and the CUNSA, though, this might not be the best option. Instead, you may need...

2.4.3 The V/oct Input: Filter Tracking

This CV input (C.6) is very similar to the frequency CV input, but it has two major differences.

- It doesn't have attenuverters;
- It responds to V/oct control signals.

These differences mean that if we patch a V/oct signal tuned to musical intervals, the filter will change the cutoff frequency just like an oscillator will change its pitch to form "notes." A common term for this is 'filter tracking,' and it has a major impact on sound design. See the Core Concept § 8.2 above.

With CUNSA's V/oct inputs, it is possible to make the filter track over more than four octaves.

However, being able to track "like an oscillator" isn't useful just for guaranteeing mathematically precise overtones. It can be crucial to "play" the filter when self-oscillating, a feature possible only through the Q parameter (see § 2.6.1 below).

2.4.4 The Ping Circuit

The final way to control the cutoff frequency is the Ping circuit (C.7), which we can describe as a DC-coupled version of BRENSO's section of the same name.

It consists of a nonlinear slew limiter that integrates only the descending voltages. For example, if we patch a trigger to the ping input, the rising edge will be almost immediate, while the falling one will have a slower decay that depends on the *Ping Decay* control (C.8).

The result is an envelope that is routed differently to the cutoff frequency and the input VCA (when engaged through the *Behavior* switch B.4).

In other words, every descending CV patched to its input will be integrated, like through a slew limiter whose response curve is inspired by the behavior of vactrol-based circuits. Assigning it to both the filter and the VCA will create timbers similar to those obtainable with certain settings of circuits generally called "Lowpass Gates" or "LPGs."¹¹

The response time is defined by the Ping Decay knob: at its leftmost position, the integration will be fast; at its rightmost position, the integration will be much slower.

2.5 EMPHASIZING THE CUTOFF FREQUENCY

The Q circuit reintroduces the filtered signal to the filter's input and creates a feedback loop that emphasizes the cutoff frequency.

The Q knob (D.1) regulates the amount of signal sent back into the filter. When fully counterclockwise it is deactivated. Rotating it clockwise will boost the harmonic content around the cutoff frequency and, by contrast, reduce the presence of the filtered frequencies.

Around noon, the Q circuit is distinguishable, and the filter is resonating.

From around three o'clock onwards, the filter is self-oscillating. A distinct frequency is now clearly audible on top of the input signal, tuned around the cutoff frequency. When fully counterclockwise, the resonance is at its extreme setting.

It is possible to control the Q setting via its dedicated CV input (D.2), which accepts voltages between -10 and 10 V and features an attenuverter (D.3).

A moderate Q setting will make the filter sweep more noticeable, whether through the frequency knob or CV.

2.5.1 Resonance and Bass

Many lowpass filter designs cause the signal's amplitude to drop significantly at high Q settings. While this is a natural part of certain filters' signature sound, we at Frap Tools preferred a more controlled behavior in the low range.

¹¹ (Strange 1984, 28)

We thus designed the Q circuit so that it doesn't reduce the signal's amplitude even when fully resonating. This is perfect for shaping bass sounds with lowpass filters since it retains all the low frequencies below the cutoff point.

2.6 SPICING UP THE SATURATION

The most crucial part of the filter design is the Character circuit: it defines the behavior of the saturation stage and thus affects the shape and amplitude of the sound coming out of it and going into the filter.

A consequence is that the Character circuit affects both the saturation color of the input gain knob over the input signal and the nature of the Q circuit, which feeds the filter's output back to the input. This second behavior is maybe the crucial one and knowing the interdependence of Q and Character will allow you to get the most out of the filter.

To change the saturation color, use the Character knob (E.1). The leftmost position is the mellower one: CUNSA will block the amplitude at a certain level and gently clip the signal past such threshold. The result is a "warm" and "fat" filter tone and a clear and whistling resonance at high Q settings.

Pushing the Character to the right progressively removes this taming effect, making the distortion crispier and louder and the resonance less controllable when engaged.

The rightmost position bears the most extreme setting, with no soft clipping over the input. The signal is louder and drives the circuit to the limit, also resulting in a sharper distortion. The resonance is wild and screaming.

It is possible to control the Character behavior through a CV input (E.2) with a dedicated attenuverter (E.3).

2.6.1 Using CUNSA as an Oscillator

When we set the Character knob towards the rightmost position and push the Q control past its resonance point, we cause a filter self-oscillation that can output a sine wave even without a signal patched to the filter's input.

If we use the V/oct input to control the filter's frequency with quantized CVs, we can use it as an actual sine wave oscillator.

To better tune it, we can take advantage of the Fine frequency knob (C.3). Since CUNSA has four filters, it can become a quadruple sine wave oscillator.

However, please remember that the filter is not an oscillator, and you shouldn't expect pristine tracking like the BRENDO. We guarantee a ± 5 cents deviation over roughly four octaves, but the oscillating behavior is still a byproduct of the filter design, and CUNSA should not be expected to perform like an actual oscillator such as the BRENDO.

Please also remember that changing the Q setting will also change the pitch, so ensure to find the most suitable Q setting before tuning the filter.

2.6.2 Ringing the Filter

A common technique for resonant filters is called "ringing" or "pinging."¹² Since we at Frap Tools already used the term "ping" for another circuit both on the BRENDO and the CUNSA, we will stick to the term "ringing" to avoid ambiguities.

To ring a resonant filter, set its Q and Character levels right before it starts to self-oscillate. Then, patch a timing pulse like SAPÈL's clock output to its audio input. The immediate voltage burst will excite the filter circuit just enough to make it briefly oscillate, or "ring."

It is quite an extreme technique, and it might complicate the process of melodically tuning the filter; however, it is still worth experimenting with the V/oct inputs to achieve a polyphonic plucked sound.

3 LINKED FILTERING

Using CUNSA as four independent filters is surely rewarding, but there's much more.

The true strength of the CUNSA comes from the interaction of the four filters, which can be used together or in different subgroups through a series of semi-normalled connections and group outputs.

3.1 GROUP OUTPUTS AND MIXING SECTION

Besides the three mode outputs for each filter, CUNSA also features four group outputs that provide various sound mixtures that you can define through the output level knobs.

The *All* output (A.9) offers a sum of all four filters. It is possible to define each filter's amplitude through its corresponding *Output Level* knob (B.3). These are especially useful when the filters have different Character settings, which can create a huge amplitude difference between two filters, and it is thus necessary to level them.

The *Left* and *Right* outputs (A.7, A.8) provide a sum of filters 1+2 and 3+4 respectively, according to the corresponding output level knobs. It is thus possible to use CUNSA as a double stereo filter by patching the signals to the semi-normalled inputs 1 and 3.

Since the four CUNSA filters are multimode, it is possible to choose which mode to send to the output mixer through the *Routing Switches* (A.5): lowpass, bandpass, or highpass. In this way, it is possible to blend, for example, a lowpass filter, two bandpass filters, and a highpass filter, and control their frequency simultaneously through the semi-normalled V/oct inputs.

¹² (Strange 1984, 152)

It is possible to drive these outputs through irresponsible use of the input gain knob, the Character parameter, and the output knob: in those cases, the output LEDs will flash red. But don't worry! The distortion can be a desired effect, and feel free to crank everything to the maximum level to achieve a ridiculous distorted sound.

Finally, the *Dry* output (A.6) provides a sum of all the signals patched to the filter inputs before the filtering stage and after the input gain. It is thus a dry signal, but it still retains any potential saturation that we may have introduced through the input gain knob. It is thus possible to use the CUNSA as a high-quality mixer that can add a bit of saturation as well.

Remember that whenever the Behavior switches are set to Filter+VCA, the cutoff frequency *will* affect the presence of a signal in the Dry output mix, since it works over the input VCA. For example, if you are pinging the filter and using it in the combined behavior, you will experience the corresponding attenuation over the dry sound as well. If the filter behavior is set to Frequency only, the signal's amplitude in the Dry mix will be unaffected. See § 4.4 below.

The Output faders too won't affect the Dry output, since they only control the filters' outputs.

3.2 SEMI-NORMALLED CONNECTIONS

You may have noticed that some inputs of the four filters are close to the corresponding knob, while others are grouped on the left side of the interface.

This last group contains, from top to bottom, the VCA CV inputs (B.2), the filter inputs (A.1), the V/oct inputs (C.6), and the Ping inputs (C.7): they refer to filters 1 to 4 from left to right.

We grouped them to make it more understandable that each filter's input is semi-normalled to the filter at its left, according to the dashed arrows.

So, for example: if we patch a CV to filter 3's V/oct input, we'll route it also to filter 4. If we patch an audio signal to filter 1's input, we'll route it to all four filters. If we patch two triggers, one to filter 1's Ping and the other to filter 3's Ping, the first trigger will ping filters 1 and 2, and the second trigger will ping filters 3 and 4.

This semi-normalled connection system allows you to use CUNSA as a single quadruple filter, as two double filters, or as a single filter and a triple filter. Every semi-normalled connection works in the same way, with one little exception.

3.2.1 Breaking the Semi-normalled Connections

It is common practice to use dummy cables to break semi-normalled connections. For example, if we want to ping filters 1 and 2 and use filters 3 and 4 for some sweeps, we can use a dummy cable to remove filters 3 and 4 from the effect of the ping signal.

The same is true for every circuit, except for the VCA. Since the knob becomes an attenuverter when the input carries a control voltage, a conventional semi-normalled connection would have caused it to simply shut off with a dummy cable, making it *de facto* impossible to use the filter. (The VCA attenuators would have multiplied a zero, becoming useless.)

Even if it's the "correct" behavior, it still sounded quite counterintuitive to us: we thus designed the semi-normalled connection so that a dummy cable keeps the VCA working with an internal reference voltage that allows the knob to be used.

In other words, patching a dummy cable to the VCA CV input causes the knob to work as if no CV at all is patched.

4 THINGS WORTH KEEPING IN MIND

CUNSA is a complex ecosystem where many things are connected and have reciprocal effects. It is not uncommon that a parameter modification might have a sort of "butterfly effect" over other two or three points of the circuit. It is thus important to spend some time tweaking the knobs and experimenting with semi-normalled connections to get the most out of it.

This is a selection of connected behavior and reciprocal influences worth keeping in mind.

4.1 GAIN STAGING AND SATURATION

There are three points where you can increase your sound's amplitude to the point of distortion:

1. At the filter's input through the input gain knob (B.1);
2. Inside the filter, through the Character knob (E.1);
3. At the filter's group output, through the output level knob (B.3).

These three stages have different purposes and saturation timbres. The LEDs provide a visual indication of the saturation of a given stage.

If you want a clean tone, you may want to use the input gain below the saturation point right before the LEDs starts clipping, and the Character fully counterclockwise. The input gain depends on the signal's amplitude, of course, but with an average 10 Vpp signal, the safe zone is up to 3 o'clock.

If you want a distorted sound, it may be useful to understand which kind of saturation the different stages introduce.

Overloading the filter input will generally emphasize the mid-low overtones and give more "punch" to the filter. Overloading the internal filter stages by rotating the

Character knob to the left will emphasize the mid-high overtones and make the sound more piercing.

Overloading the Left and Right outputs or the All output, for example by routing the same signal to all the filters tuned to the same frequency, will increase the higher overtones, and make the sound crispier.

It is also possible to overload the Dry filter output by saturating more VCAs. The sound will become punchier with more mid-overtones.

When using a highpass filter, the distortion will create some non-linearities around the cutoff frequency that will further change the sound spectrum.

4.2 Q, RESONANCE, AND FILTER SLOPE

Understanding the reciprocal effects of the Q and saturation circuits is crucial to grasp the whole sonic palette of the CUNSA, so it is worth spending some time tweaking these knobs.

A good practice could be starting with both knobs counterclockwise and sweeping only one. Then, rotate the other knob by small increments and repeat the sweeps, paying attention to the differences brought in by every small turn. Finally, repeat the procedure but this time sweep the other knob and increment the first one.

There are infinite combinations, and we encourage you to experiment and find your favorite ones. Some that we feel worth checking out are:

- Q at 3 o'clock and Character at noon is good for some rich filter sweeps;
- Q at noon and Character at 3 is great for a mildly distorted filter.
- Both Q and Character around 9 provide a fat but clean filter with a precise cutoff slope.
- Both Q and Character around 4 will cause the filter to self-oscillate.

4.3 WORKING WITH SEMI-NORMALLED CONNECTIONS

The four semi-normalled modulation targets allow to control multiple filters at the same time, but they may lead to some unwanted behavior that can be avoided with the right mindset.

For example, if we want to use filter 1 as a pinged low-pass filter, filter 2 as a voltage-controlled resonant band-pass filter, and filter 3 as an extra lowpass filter that we manually sweep, we must:

- Patch a trigger signal to filter 1's Ping input;
- Patch a V/oct signal to filter 2's V/oct input.

However, at the same time, we must also:

- Exclude filter 2 from filter 1's trigger signal;
- Exclude filter 3 from filter 1's trigger signal and filter 2's V/oct signal.

If we forget to break the semi-normalled connections, filter 2 wouldn't play a melody because it will keep opening and closing according to filter 1's ping signal, and filter 3 will combine such signal with filter 2's V/oct CV, thus making a manual sweep impossible.

To break the semi-normalled connections, we can simply use a dummy cable. The connections will thus be something like the following table:



	Filter 1	Filter 2	Filter 3	Filter 4
	Empty	V/oct	Dummy	Empty
	Trigger	Dummy	Empty	Empty

Table 27: An example of semi-normalled connection.

4.4 THE COMBINED BEHAVIOR

When we use the Combo behavior through the Behavior switch (B.4), CUNSA will reduce a filter's amplitude below a certain cutoff frequency.

The most intuitive use is to mimic an organic and natural decay through the Ping circuit. However, this may cause an unexpected, yet logical behavior at the dry output level.

Since the Dry output picks the signal right after the VCA, its amplitude will also be affected by the ping circuit, with a ducking effect, just like if we modulated the VCA with an external envelope.

But there's more: with the Combined behavior, *every* control over the cutoff frequency will reduce the VCA amplitude, including the Frequency knobs and the V/oct input.

So, for example, if we do a filter sweep with the frequency knob, we will experience a slight volume drop once we approach the lowest range. This becomes especially noticeable (and uncanny at first) with highpass filters: when the cutoff frequency is low, the filter gets more open, but the volume still decreases.

This side effect of the combined behavior can become useful when the filter has high Q settings. In some circumstances, the resonance might become louder in the lower range than in the higher one: activating the combined behavior will gently reduce its amplitude and thus even out the filter response.

5 TECHNICAL DATA

5.1 SIGNAL FLOW

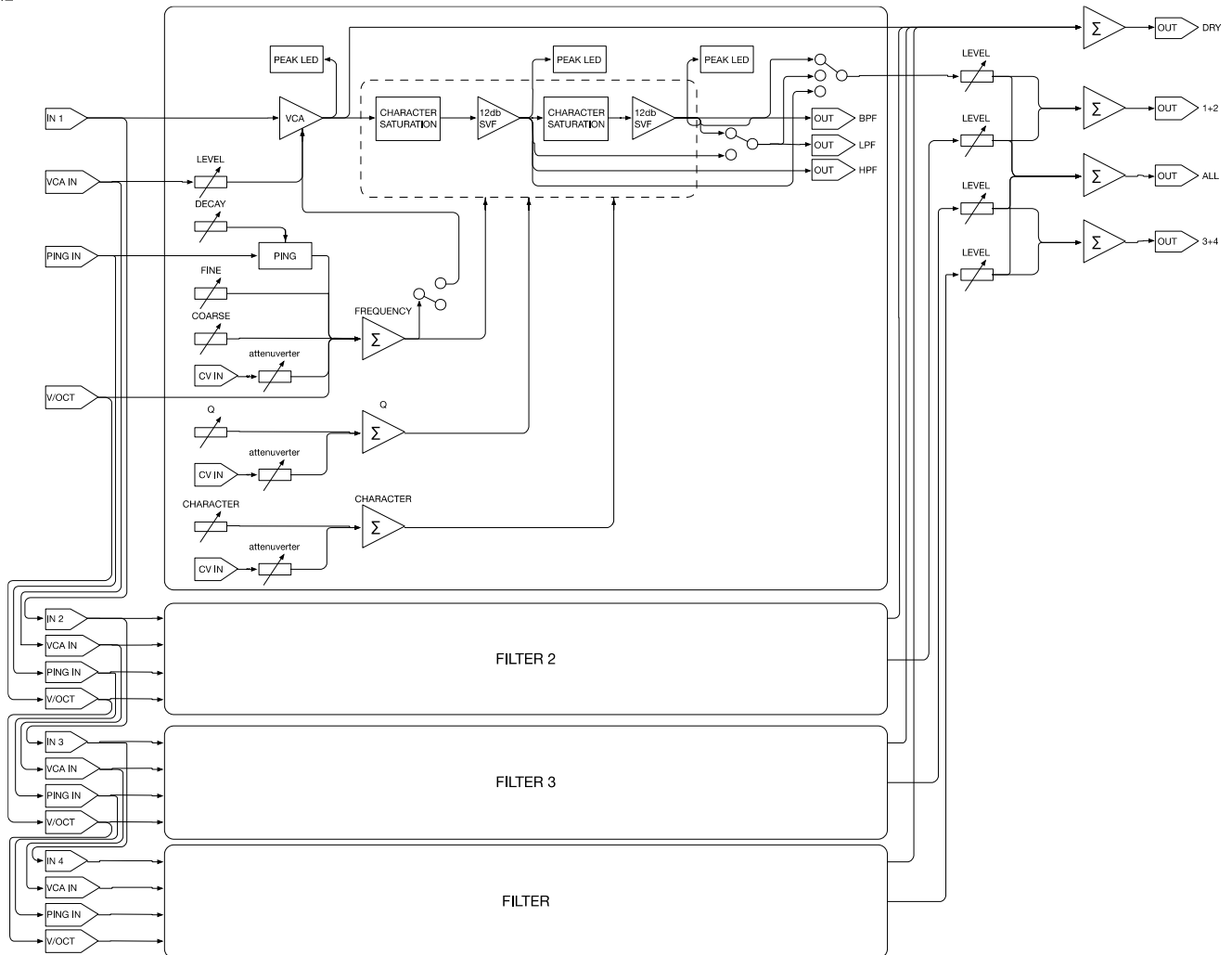

Figure 98: CUNSA's signal flow.

5.2 SPECIFICATIONS

Parameter	Details		Min	Typ	Max	Unit	
Size				42		HP	
Depth				38		mm	
Current Draw	+12 V			330		mA	
	-12 V			330			
Input details (1)	Impedance	Audio	Single	20		kΩ	
			Quadruple	5			
		VCA CV	Single	50			
			Quadruple	12,5			
		V/oct	Single	90			
			Quadruple	22,5			
		Ping	Single	90			
			Quadruple	22,5			
Attenuverted CVs			100				
Output details	Impedance	All outputs	100			Ω	
Filter details	Slope	Lowpass	12		24	dB/oct	
		Bandpass		12			
		Highpass		12			
	Knob range			<18		>21000	Hz
	Tracking (2)				±5		ε
Fine-tuning					>1	st	
Sine wave amplitude (3)	Lowpass	24 dB/oct	±3	±3,5	±4	Vpp	
		12 dB/oct	±1,2	±1,5	±1,8		
	Bandpass		±3,2	±3,7	±4,2		
	Highpass		±0,8	±1	±1,2		
Gain scale (4)	Individual output maximum filter gain	Lowpass (5)	24 dB/oct	0		+2	
			12 dB/oct	0		+2	
		Bandpass (6)			-7,5		-5
	Highpass (7)			-4		-2,5	
	Output level knob gain	1+2 and 3+4 outputs			+6		
		ALL output			+1,5		
Dry output gain				-5			
CV input range	Cutoff frequency	Usable voltages		-10		10	
		Absolute knob offset			10		
	Q	Usable voltages		-10		10	
		Absolute knob offset			10		
	Character	Usable voltages		-10		10	
		Absolute knob offset			10		
	Ping	Usable voltages		-10		10	
		Absolute knob offset			10		

- (1) All buffered.
- (2) Measured at 440 Hz over ±2 octaves.
- (3) Unloaded. Measured with Q and Character knob fully counterclockwise and a frequency in the middle of the bandwidth. No Combo mode.
- (4) Measured with a 1 kHz sine wave with maximum VCA gain, Character knob fully clockwise, Q knob fully counterclockwise (no Q).
- (5) Maximum cutoff frequency.
- (6) Cutoff frequency centered at 1 kHz.
- (7) Minimum cutoff frequency.

BAGÀI

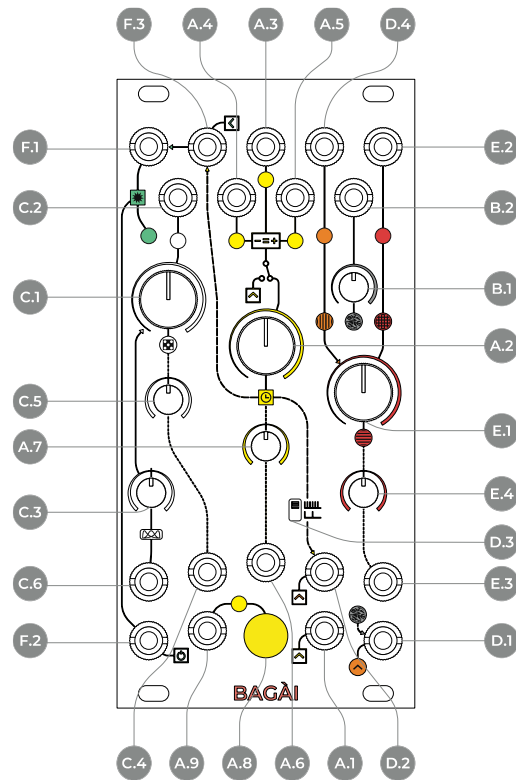

Figure 99: BAGÀI interface.

A Clock

- A.1 Clock Input
- A.2 Clock Rate
- A.3 Main Clock Output
- A.4 "Minus" Random Clock Output
- A.5 "Plus" Random Clock Output
- A.6 Clock CV Input
- A.7 Clock CV Attenuverter
- A.8 Clock Hold Button
- A.9 Clock Hold Gate Input

B Noise

- B.1 Noise Color

B.2 Noise Output

C Fluctuating Random Voltages (FRV)

- C.1 FRV Rate
- C.2 FRV Output
- C.3 FRV Probability Distribution
- C.4 FRV CV Input
- C.5 FRV CV attenuverter
- C.6 Probability Distribution CV input

D Sample and Hold (S&H)

- D.1 S&H Input
- D.2 S&H Clock Input

D.3 S&H Internal Clock Rate

D.4 S&H Output

E 8-Bit Quantized S&H

- E.1 Bit Depth
- E.2 Quantized S&H Output
- E.3 Bit Depth CV Input
- E.4 Bit Depth CV Attenuverter

F Clock Burst

- F.1 Clock Burst Output
- F.2 Burst On/Off Gate Input
- F.3 Burst Clock Input

1 PHILOSOPHY AND DESIGN

BagàI is an analog sample and hold, bitcrusher, and downsampler, also capable of generating fluctuating random voltages, colored noise, and clock bursts.

It consists of six highly intertwined sections:

1. A clock with straight and random outputs (yellow)
2. A thermal noise generator with variable color (grey)
3. A bipolar fluctuating random voltage generator (white) with variable rate

4. A sample and hold the circuit (henceforth S&H, orange) with selectable time scale, slow for modulation, or fast for audio sampling up to 48 kHz.
5. An 8-bit quantized version of the orange S&H circuit with variable bit depth (red)
6. A clock burst section (green).

2 THE CLOCK

The clock knob controls two clock circuits simultaneously: the first one, which we will call *modulation clock*, has a range from 4.5 seconds to 61 Hz and feeds the clock

outputs ($- = +$), the sample and hold section, and the burst section. Its color is yellow.

The second one, which we will call *audio clock*, has a range from 25 Hz to 34 kHz. It is an alternative internal clock for the S&H section only and can be selected through the S&H internal clock switch (D.3). The audio clock does not have a physical output, it is just an internal value, and since it belongs only to the S&H circuit, its color is orange.

The frequency knob affects both clocks at the same time: left is slow, right is fast.

The Modulation Clock signal is available from the main clock output (A.3) in the form of a two-millisecond trigger stream.

The two additional random clock outputs provide a randomized behavior like Sapèl's random clock: the “-” clock (A.4) randomly subtracts clock impulses from the main one, while the “+” clock (A.5) randomly adds impulses. The rate at which both clocks deviate from the main one depends on the *Global rate of change* setting, on which see §4 below.

2.1 INTERNAL CLOCK ROUTING

The clock affects 3 sections:

1. The Burst, through a semi-normalled connection to the burst clock input (F.3).
2. and 3. The sample and hold and its quantized version (bitcrusher) through a semi-normalled connection to the S&H clock input (D.2).

In the Burst section, the clock is simply summed to the burst generator, on which see §7 below; in the sample and hold sections, the clock triggers the sample-and-hold circuit.

However, it is important to note that these two semi-normalled connections stem from the “knob,” not from the “output” or “input:” in other terms, the clock going to the Burst and S&H circuit will always be the internal one, even when an external clock is patched to the Clock input (A.1).

If you want to use an external clock both for the clock randomization process and the S&H or Burst section, simply cross-patch the “=” clock output (A.3) to the desired input (D.2 or F.3)

2.2 MODULATING THE CLOCK

It is possible to play with the internal clock in three ways:

1. Modulate it through its CV input (A.6) with attenuverter (A.7).
2. Override it through the external clock input (A.1).

3. Freeze it through the clock hold button (A.8) and the gate input.

Bagà is a bit different than Sapèl and the clock modulations do not all have the same effects.

The CV modulation will impact the clock outputs, the Burst section, the S&H, and the quantized S&H.

The other two operations (overriding and freezing) will impact only the clock outputs. This design allows you to play with the clock inputs and outputs while still using Burst and S&H with a regular internal clock. It is especially useful when the S&H is used as an audio effect, see §5.2 and 6.2 below).

However, if you want to use Bagà more like Sapèl, with the button, gate, and clock inputs affecting the S&H circuit, simply crosspatch the “=” clock output (A.3) to the desired input (D.2).

3 NOISE

Bagà has an internal thermal noise generator that is the default source for the sample and hold and the fluctuating random voltage circuits.

Besides that, the noise also feeds a filtering stage, controlled by the noise color knob (B.1), before getting out of the noise output (B.2). When the knob is fully counter-clockwise, the noise will have a brighter tone, and it will get progressively darker as we rotate the knob clockwise.

It is thus possible to recreate some of Sapèl's noise colors but in a continuous way.

As we said, the default source for the fluctuating random voltage and the sample and hold circuits is not filtered to guarantee the purest Gaussian distribution proper of analog noise. However, it is possible to use the filtered output for the sample and hold circuit by cross-patching it to the sample and hold input. Changing the noise color will produce an effect like the probability distribution. (The fluctuating random voltage does not need such cross-patching because it already features a probability distribution section.)

4 FLUCTUATING RANDOM VOLTAGE (FRV) AND GLOBAL RATE OF CHANGE

The white section is identical in concept to Sapèl's fluctuating random voltage: it is an analog sample-and-hold circuit that samples the module's analog thermal noise and integrates the value with a custom slew limiting circuit. The sampling rate is defined by its clock (C.1), which is completely independent from the main one. The result is a constant and unpredictable fluctuation available from the FRV output (C.2).

The FRV features a CV input (C.4) with attenuverter (C.5) that modulates its clock's speed, so the fluctuation rate.

You can read more about fluctuating random voltages (FRV) in Sapèl's chapter, § 4.3 above. Bagàì differs only in two aspects: its clock speed, whose range is a bit wider, and its output voltage range, which is bipolar as opposed to Sapèl's unipolar one.

Just like Sapèl, the voltage generated by this circuit is also internally used to create the two random clock behaviors (Global Rate of Change, see Sapèl's chapter, § 4.3). On top of that, on Bagàì it also takes care of creating the clock bursts, on which see § 7 below.

The FRV features a voltage-controllable probability distribution parameter (C.3) that defines the average magnitude of the generated voltage. Rotate the probability distribution knob to the left to have a higher probability of outputting low voltages, close to -5 volts. Rotate it to the right to have a higher probability of outputting high voltages close to the 5 V limit.

When patching a control voltage signal to the probability distribution input (C.6), the knob acts as an offset.

Since the fluctuating random voltage also affects the random clock outputs and the clock burst, it is important to pay attention to the probability distribution knob as well, because it will have a major impact on those circuits.

A low or high probability distribution will cause the fluctuating voltage to stick at one of its extremes, reducing the number it crosses the 0 V threshold and thus the random clock's rate of change.

As for the bursts, the FRV affects their speed, so an extreme setting will cause a more static or even silent behavior.

5 SAMPLE AND HOLD AND DYNAMIC DOWNSAMPLER.

The orange section is a plain sample-and-hold circuit (S&H) much like Sapèl's unquantized output, with three major differences:

1. it is bipolar;
2. it can sample up to 48,000 times per second;
3. It can sample every signal, not just noise.

5.1 SAMPLE AND HOLD BEHAVIOR

By default, the S&H works with the Modulation clock (see § 2.1) and its input is semi-normalled to the noise generator, so it will sample random values at the rate defined by the clock speed and output them through the S&H output (D.4). Its range is bipolar, and it is between -5 and 5 V.

It is possible to sample signals other than the internal thermal noise by patching them to the sample and hold input (D.1).

For example, sampling a triangle LFO with a moderately fast Modulation clock will produce a stepped series

of voltages going up and down, much like an unquantized scale. Experiment with different inputs, both bipolar and unipolar, to see what sampling does to them.

It is also possible to use an external clock to trigger the S&H circuit by patching it to the S&H clock input (D.2). This operation will override the semi-normalled connection from the internal clock, but it will affect the S&H only: the clock outputs (A.3, A.4, A.5) and the clock burst input (F.3) will continue receiving the internal modulation clock. (Qual è il range di ingress)

5.2 AUDIO SAMPLING AND DOWNSAMPLING

Distinctive features of Bagàì's S&H circuit are that the clock can go up to 48 kHz and that its input can accept audio signals. Combining those features results in analog sampling as described in the Core Concept section number 11.1.

To activate the Audio clock set the internal clock rate switch (D.3) to the upper position. Now its range will be from 25 Hz to 34 kHz. Remember that this behavior only affects the internal sample and hold circuit: the clock output will always output the Modulation clock.

Patching an audio signal to the S&H input with the clock at audio rate and its knob fully clockwise will result in an output signal almost identical to the input one. However, reducing the clock speed will translate into a change in the sampling rate, a technique often called downsampling.

At low audio clock settings, the output signal will start to change its harmonic content due to the progressively higher foldover that introduces spurious overtones.

The sound is very dissonant, but it is possible to tame this technique by using a tracking oscillator as a clock, just like we would do with carriers and modulators in FM patches. In this way, the foldover will track together with the incoming audio signal and its spurious tones will always be proportioned to the fundamental frequency.

Another peculiar effect would be modulating the clock with an inverted envelope to obtain only a brief dissonant transient at the beginning of every note.

6 8-BIT QUANTIZED SAMPLE AND HOLD

This section performs the same operation as the analog sample and hold but quantizes the output to a fixed series of 256 values defined by an 8-bit circuit. It is affected by the clock switch as well, so it is possible to use it with both modulation and audio sources.

6.1 QUANTIZED SAMPLE AND HOLD

The default behavior with the modulation clock is indeed like Sapèl's $n + 1$ and 2^n circuits. Both modules

limited the pool of values sampled by the sampling hold to a fixed number.

However, Bagàì has two more bits that increase the quantization mask's resolution up to 256 values.

Moreover, it can also change the number of active bits, so it is possible to dynamically change our quantizer's resolution. To do so, use the bit depth knob (E.1). When fully counterclockwise, eight bits are active, and the output will be quite like the analog sample and hold output.

Rotate it clockwise to reduce the number of active bits: the pool of values will become exponentially lower (128, 64, 32, 16, 8, 4, 2). When fully clockwise the circuit will output only two voltages and it will eventually become a gate output. It is worth noting that this kind of S&H quantization works oppositely to Sapèl's 2^n and $N+1$ outputs. While those circuits kept the bits always active and changed the amplitude of the sampled signal, Bagàì keeps the amplitude fixed and changes the number of active bits. In one case we have an output with fixed resolution and variable magnitude; in the other, a signal with fixed amplitude and variable resolution.

6.2 BITCRUSHING

When we perform audio sampling and downsampling on Bagàì we can use its quantized output to change the bit depth, thus obtaining a bitcrusher behavior like described in the Core Concept section 11.2.

Having the knob fully counterclockwise will result in an 8-bit audio conversion and rotating it to the right will cause it to progressively reduce its quality.

Try using an LFO or an envelope to modulate the bit depth!

Warning: since this circuit is also meant to process the CV, the output is DC coupled.

When using it with audio signals, we recommend using an AC-coupled module afterward, such as a filter or an audio-only mixer like our CGM: it will remove any DC offset from the audio signal and make it safer for your speaker's cones to reproduce.

7 CLOCK BURST

The Clock Burst output of the green section (F.1) provides a sum of two signals, which are by default the main clock and the bursts.

The bursts are unpredictable streams of fast gates that appear at random moments. Their frequency and density depend on the global rate of change setting, defined, as usual, by the fluctuating random voltage frequency (C.1).

Also in this context, the probability distribution can have a fundamental impact on the burst behavior, much like with the classic random clock outputs.

The default output is this a mix of burst and main clock, but it is possible to vary its mix in many ways.

To dynamically control the bursts, patch a gate signal to the burst on/off gate input (F.2). High gates will play the bursts, low gates will stop them. A dummy cable will remove the bursts completely. The burst LED flash is green whenever a clock impulse passes through the output.

To change the mixed clock signal, patch any trigger or gate signal to the burst clock input (F.3). The new signal will override the semi-normalled connection and be automatically summed to the bursts.

A dummy cable will remove any signal from this input, leaving just the bursts at the output.

7.1 BURSTS VERSUS RANDOM CLOCKS

While its concept may seem similar to the "+" random clock output, its design and concept are entirely different and so is its output.

- The "+" clock is always a variation of the main one; the burst is entirely independent.
- The "+" clock is always summed to the main clock, while the burst can be used also by itself, or summed to other sources.
- The additional random triggers over the "+" clock circuit have a more or less fixed speed, while the bursts are more unpredictable, and their frequency also depends on the fluctuating random voltage position.
- The global rate of change affects both circuits in a different way: on the "+" clock, it feeds a comparator whose output defines whether the clock should deviate or not from the main one; on the burst, it modulates its speed.

8 TECHNICAL DATA

8.1 SIGNAL FLOW

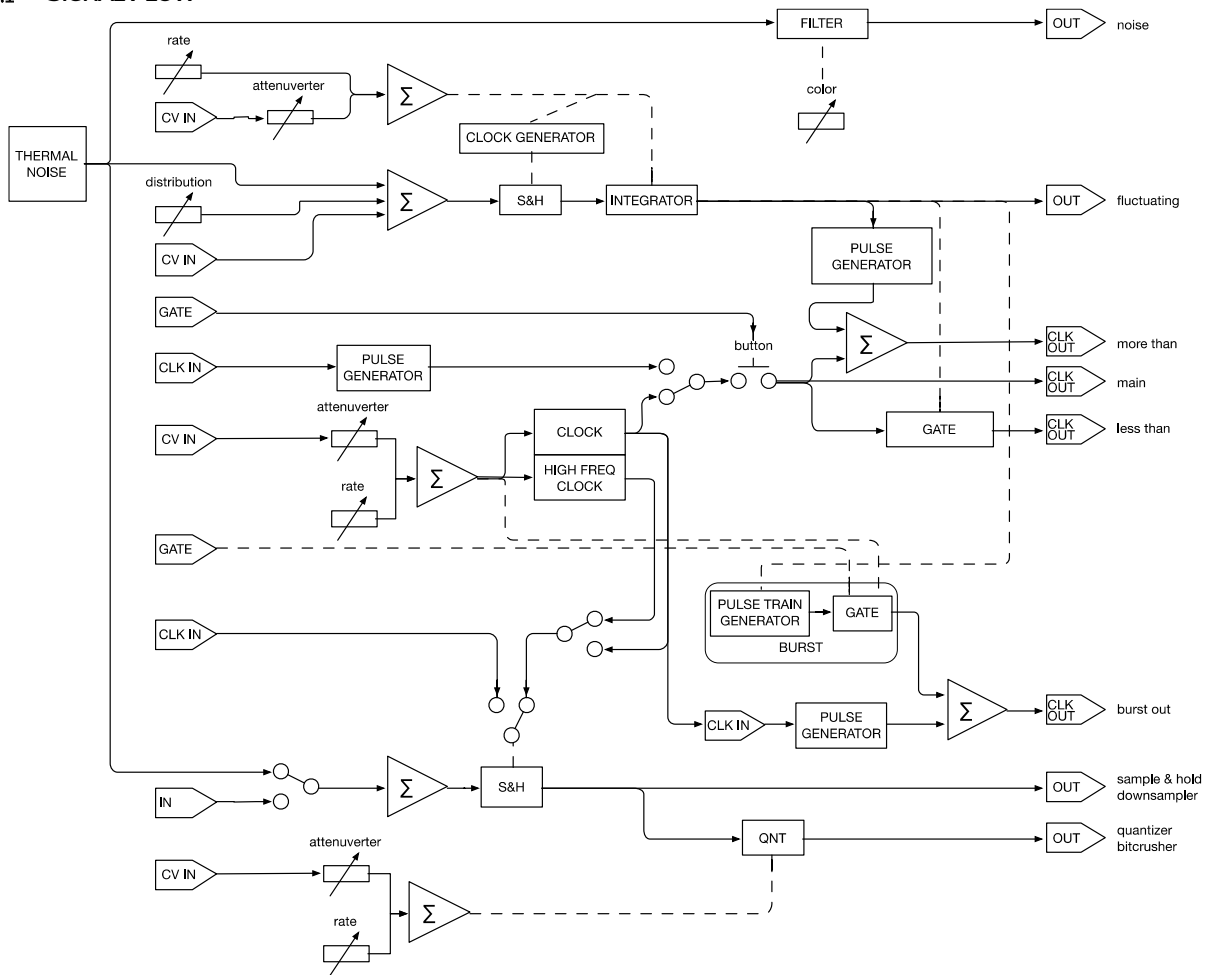

Figure 100: BAGÀ's signal flow.

8.2 SPECIFICATIONS

Parameter	Details	Min	Typ	Max	Unit
Size			12		HP
Depth			38		mm
Current Draw	+12 V			190	mA
	-12 V			90	
Recommended warmup time			30		min
CV input impedance			>90		K Ω
Clock input impedance	on positive pulses		>100		K Ω
	clamping negative pulses		~30		
Built-in clock frequency (10)	Audio clock		~0.05	75	Hz
	Modulation clock		~0.025	34	kHz
Clock output	period		~2		ms
	amplitude		~9		V
Sampling Glitch	Filtered				
Noise output	Level		10		dBU RMS
	global tolerance		-3	3	dB
CV input range	Clock frequency	Usable voltages	-10	10	V
		Absolute knob offset		12	
	All other inputs	Usable voltages	-10	10	
		Absolute knob offset		10	

(8) All buffered.

(9) Measured at 440 Hz over ± 2 octaves.

(10) Unloaded. Measured with Q and Character knob fully counterclockwise and a frequency in the middle of the bandwidth. No Combo mode.

(11) Measured with a 1 kHz sine wave with maximum VCA gain, Character knob fully clockwise, Q knob fully counterclockwise (no Q).

(12) Maximum cutoff frequency.

(13) Cutoff frequency centered at 1 kHz.

(14) Minimum cutoff frequency.

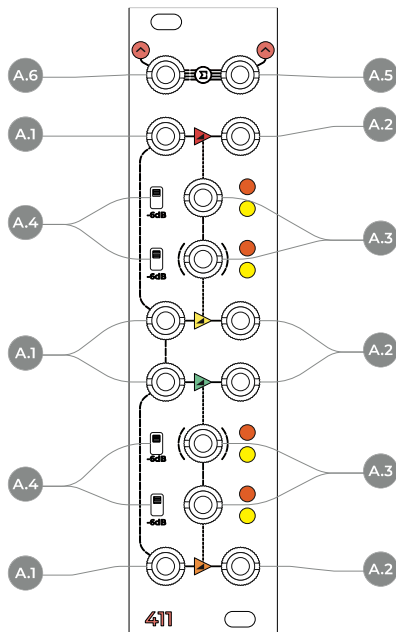

Figure 101: 411 interface.

A Connections

- A.1 Signal Inputs
- A.2 Signal Outputs
- A.3 Control Inputs
- A.4 -6dB Switches
- A.5 Sum Output
- A.6 Unpatched Sum Output

The 411 is a quadruple linear VCA, mixer, and multiple for audio and CV. It consists of four linear VCAs with semi-normalled inputs and CV inputs, -6 dB attenuation switches, a mixed output, and an unpatched output.

9 DESIGN

The four VCAs are identical and they are similar in design and behavior to Brenso's timber bus VCA.

Each consists of an input (A.1), an output (A.2), a unipolar CV input (A.3), and a -6 dB attenuation switch (A.4).

The inputs and the unipolar CV inputs are semi-normalled so that every signal patched to a VCA input also feeds the ones below it: write the feeds yellow, yellow feeds green, and green feeds orange.

The VCAs are designed so that the circuit stays open when nothing is patched in the CV input.

It is thus possible to use it as a rudimentary multiple: however, the VCAs will always introduce some slight amplitude alterations, so we wouldn't recommend it for high-precision voltages like V/oct signals. For that purpose, the 333 is better.

The -6 dB switches halve the signals' amplitude. However, since the semi-normalled connections are over the inputs, the switches will not affect the cascaded sections, contrarily to the 333 module.

The VCAs are DC coupled, so they suit both audio and CV. When used with audio they are particularly recommended for audio-rate amplitude modulation. They can be used for classic voltage-controlled amplification, but you may want to use exponential CV shapes for a more natural effect for the ear.

The 411 has two mixed outputs identical in concept to the 321's ones. The *Sum* output (A.5) provides the sum of all the signals passed to the 411. The *Unpatched* output (A.6) provides the sum of the sections whose output is not patched elsewhere. If all the section outputs are unpatched the two mix the outputs will sound the same.

The summing stage has a custom attenuation to preserve its headroom with more signals, but it is still possible to saturate it.

The 411's architecture allows to use it in many ways, for example:

- process four signals independently;
- Modulate one signal with four CVS and send it to four different destinations;
- mix two audio signals and modulate them with a modulated series;
- mix up to 4 signals and modulate them with the same CV...

10 TECHNICAL DATA

10.1 FLOW CHART

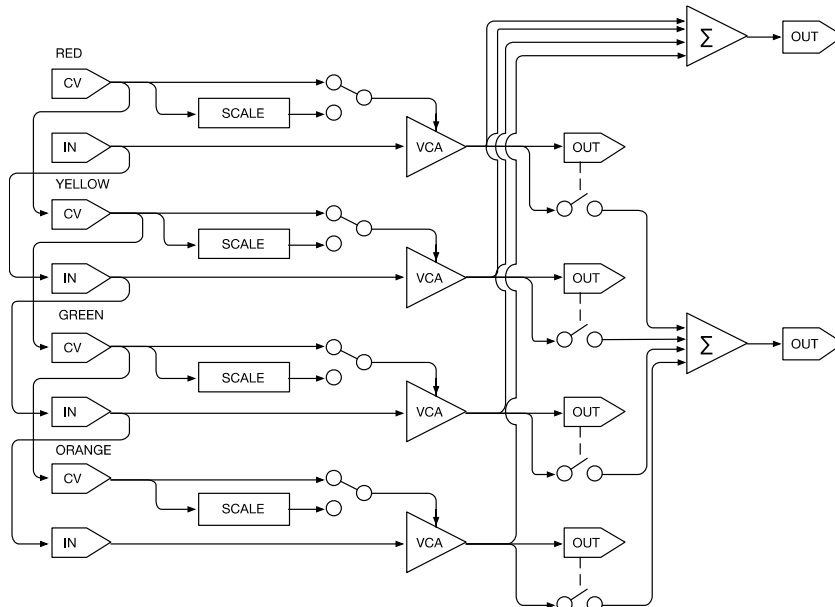

Figure 102: 333's flow chart.

10.2 SPECIFICATIONS

Parameter	Details	Min	Typ	Max	Unit
Size			6		HP
Depth			38		mm
Current Draw	+12 V			35	mA
	-12 V			35	
Recommended warmup time			30		min
Audio input impedance			>45		KΩ
CV input impedance			>40		
Audio output impedance			<50		Ω
Global CV offset per section		-20		20	mV
Frequency response (3)		DC		30	KHz
Harmonic Distortion (THD+N) (4)			<0.01		%

(1) Within 1dB, measured at +10dBu onto a 1KΩ load.

(2) Measured at 1 KHz with output signal of +10dBu onto 1KΩ load with a 10Hz to 80 KHz bandwidth measurement system.

333

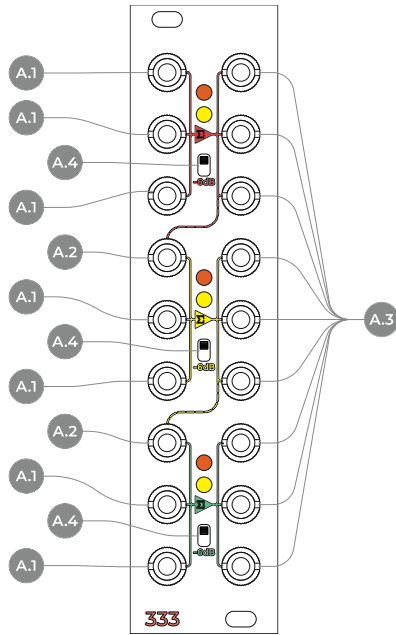

Figure 103: 333 interface.

- B** In/Out
- B.1** Inputs
- B.2** Semi-Normalled Inputs
- B.3** Outputs
- B.4** -6dB Switches

The 333 is an analog summing and distribution module for Eurorack modular systems. It is composed of three identical sections, each of those comprising a high-quality

summing amplifier with 3 inputs, and three independently buffered outputs.

The summing amplifier circuitry and the system optimization are derived directly from the CGM creative mixer series, with the additional ability to handle signals starting from DC.

1 DESIGN

Each of the three sections, red, yellow, and green, sums up to three signals, plugged into any of its three inputs, and distributes this sum to three independently buffered outputs.

Each section also features a -6 dB switch that attenuates the sum by half its magnitude, in case of particularly hot signals.

The first input of yellow and green sections (B.2) is semi-normalled to the after-switch sum result of the previous section (the yellow to the red, and the green to the yellow). Thanks to this semi-normalled connection, it is possible to use the 333 as a 1-to-9 multiple, or a 7-to-1 mixer.

All the inputs are DC coupled, so you can use each section to sum audio signals, control voltages as well as merging clocks.



Practice the 333 in many forms with these Techniques:

- [Voice Spread #1](#)
- [-6dB Switches](#)
- [Sidechain #1](#)
- [V/oct inversion #1](#)
- [V/oct inversion #2](#)

2 TECHNICAL DATA

2.1 FLOW CHART

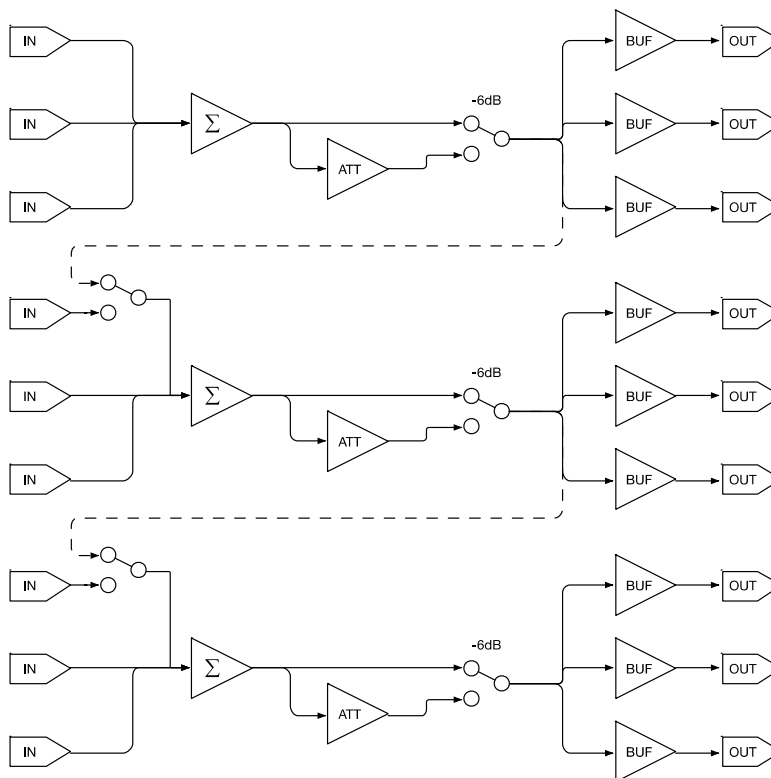

Figure 104: 333's flow chart.

2.2 SPECIFICATIONS

Parameter	Details	Min	Typ	Max	Unit
Size			6		HP
Depth			38		mm
Current Draw				48	mA
				48	
Recommended warmup time			30		min
Input impedance			>90		KΩ
Output impedance			<50		Ω
CV Tolerance				<0.5	%
		global offset per section	-20	20	mV
Frequency response (3)		DC		30	KHz
Harmonic Distortion (THD+N) (4)			<0.01		%

(3) Within 1dB, measured at +10dBu onto a 1KΩ load.

(4) Measured at 1 KHz with output signal of +10dBu onto 1KΩ load with a 10Hz to 80 KHz bandwidth measurement system.

321

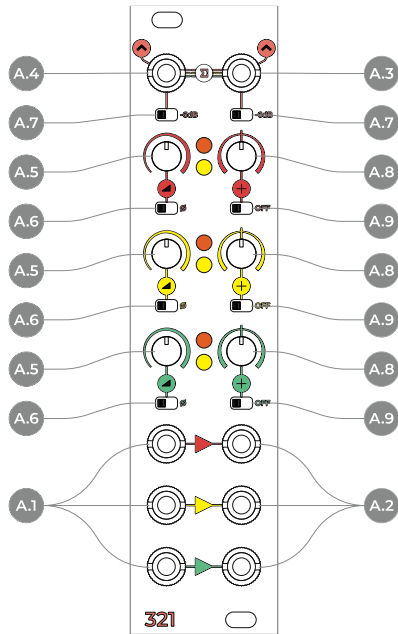

Figure 105: 321 interface.

- A 321
- A.1 Inputs
- A.2 Outputs
- A.3 Sum Output
- A.4 Unpatched Sum Output
- A.5 Scale
- A.6 Phase Switch
- A.7 -6dB Switches
- A.8 Offset
- A.9 Offset Switch

The 321 includes the most useful functions we always need in every patch, to edit and combine dynamically the signals in use.

It is capable of scaling any incoming signal, invert its phase, offset it, and combine with other signals. It is completely DC coupled, so may work well for both audio and CV. It can also be used as a CV source.

1 DESIGN

The 321 consists of three identical sections, red, yellow, and green: each can scale any signal from 0 up to 2 times (+6dB), flip its phase, and apply a DC offset, allowing you to shift your audio or CV up or down.

In case no signals are connected to the section input (A.1), the offset circuit creates a DC offset ranging from -7.5 to 7.5 V.

The three sections are then summed together into two independent summing stages: the top right jack (A.3) outputs the sum of all three sections, while the top left one (A.4) outputs the sum of the unconnected sections only (semi-normalled). The 321 is entirely DC coupled, allowing the process of control voltages as well as audio signals.

In case CVs or audio signals are particularly hot, the two 6dB attenuators (A.7), one per each summing section might be helpful to reduce exactly by 50% the incoming signals.

Practice the 321 in many forms with these Techniques:



- [Octave Blends](#)
- [Sidechain #1](#)
- [FUMANA Feedback #2](#)
- [FUMANA Feedback #3](#)
- [Offset](#)
- [V/oct inversion #1](#)
- [V/oct inversion #2](#)

2 TECHNICAL DATA

2.1.1 Flow Chart

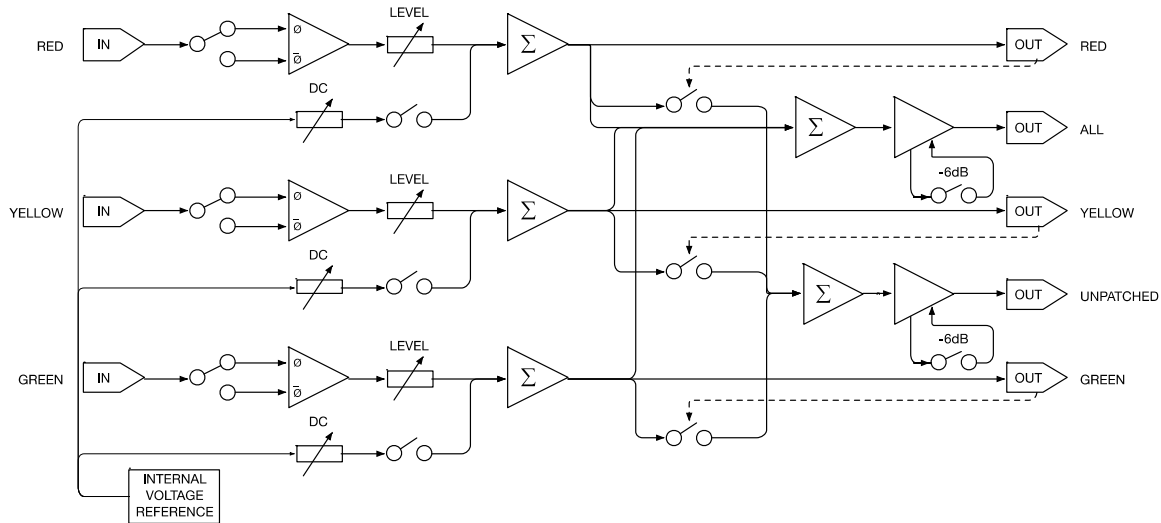

Figure 106: 321 flow chart.

2.1.2 Specifications

Parameter	Details	Min	Typ	Max	Unit
Size			6		HP
Depth			38		mm
Current Draw		+12 V		48	mA
		-12 V		48	
Recommended warmup time			30		min
Input impedance			>90		KΩ
Output impedance			<50		Ω
Frequency response (1)		DC		19	KHz

(1) Within 1dB, measured at +10dBu onto a 1KΩ load.

PLUS

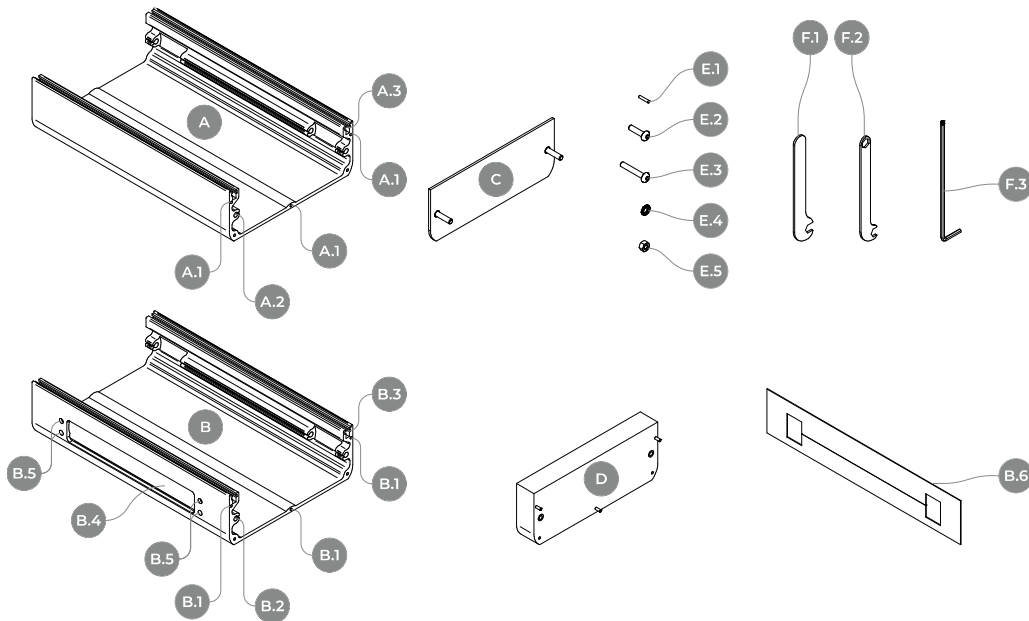

- A Single Unit**
- A.1 Dowel holes
- A.2 Mounting brackets
- A.3 Rails
- B Row Extension Unit**
- B.1 Dowel holes
- B.2 Mounting brackets
- B.3 Rails

- B.4 Window
- B.5 Row Extension holes
- B.6 Thin felt strip
- C Thin Side**
- D Wood Side**
- E Components**
- E.1 Dowels
- E.2 1.4mm M4 screws

- E.3 25mm M4 screws
- E.4 Teethed washers
- E.5 M4 Hex nut
- F Tools**
- F.1 Thick wrench
- F.2 Thin wrench
- F.3 Hex key

3 PHILOSOPHY AND DESIGN

PLUS is the first modular-modular case for Eurorack synthesizers. It is built of practical, 42-HP units that can be assembled in almost infinite configurations.

The modular synthesizer is a “liquid” instrument: it does not have a fixed shape, but it is molded by the musician’s needs and by the case it is mounted in—and it can change over time.

For this reason, one of the struggles of modular synthesists is that their case may become too small or too large for the instrument that they have in mind. PLUS was designed to solve this problem. With its flexible architecture, it can grow or shrink according to the shape of the modular synthesizer it hosts. PLUS is a case that grows in space, but also in time, following the creative direction of the artists.

However, problem-solving was not the only reason behind PLUS. It is also designed to be solid and elegant, through extruded aluminum pieces joined together with no visible screws.

As of today, four parts can compose a PLUS case: two kinds of units, which are the main body of the case, and two kinds of sides that can close it.

3.1 UNITS

The PLUS units are pieces of extruded aluminum, all of the same size (42HP). They can be combined through internal bolted joints to form longer rows or stacked upon each other to form “columns.” There are two kinds of units: *closed* and *windowed*.

3.1.1 Closed

This kind of unit can build the smallest PLUS configuration by just adding two sides. The result is a compact, 42HP Eurorack case.

If you feel like you need more room, you can join several closed units together to build longer rows.

3.1.2 Windowed

The *Windowed* units are identical in shape and size to the *Closed* ones, but they have a space (window) on one of the longer sides, as well as four tiny holes.

Place two windowed sides face to face, and you will be able to join two Eurorack rows. The four holes allow bolted joints to stack together the units, and the windows allow the power cables to pass through the rows.

Since they allow you to extend the number of rows, they are sold in pairs, called *row extension units*.

3.2 SIDES

Currently, there are two factory options to complete your PLUS case: thick wooden sides or thin aluminum sides. Both fit perfectly the shape of the rows, look gorgeous side by side, and are mounted without external screws, for a tidy and elegant look.

3.2.1 Thick Sides

These are for the fans of classic wooden sides. They are made of solid Black Limba wood and come in three textures: light, dark, or spotted. Needless to say, they look gorgeous side by side, for multi-row systems.

Two threaded metal fasteners allow the bolts to lock the sides from within the case.

3.2.2 Thin Sides

These thin, aluminum sides give the case a distinguishable look. They have a coarse finishing for a pleasant feel and come in three colors: green, yellow, and black.

They have built-in screws for joining the bolt inside the case.

4 PURCHASE OPTIONS

There are three purchase options for the PLUS units and six for the sides. They are:

- one closed unit;
- one row extension unit (a pair of windowed units);
- two row extension units (a pair of windowed units);
- a pair of Light Black Limba sides;
- a pair of Spotted Black Limba sides;
- a pair of Dark Black Limba sides;
- a pair of green aluminum sides;
- a pair of yellow aluminum sides;
- a pair of black aluminum sides.

All the sides configurations come with the screws, bolts, and tools for assembly.

According to which one(s) you chose, you may have different assembly instructions to follow.

5 ASSEMBLY INSTRUCTIONS

There are four basic assembly operations that you can do with your PLUS parts, and they may vary according to which configuration you chose. They are:

1. mounting the wooden sides to a unit;
2. mounting the aluminum sides to a unit;
3. mounting two units horizontally;
4. mounting the row extension unit (vertically).

The first three operations are the same with both closed and windowed units; the fourth one applies to windowed units only.

Any configuration of PLUS requires some or all of these four operations to be assembled.

5.1 SINGLE UNIT TO WOODEN SIDES

- (a) Connect the first wooden side to the PLUS unit by matching its three dowel pins (E.1) to the holes on the side of the case (A.1 or B.1) ensuring a proper axial alignment.

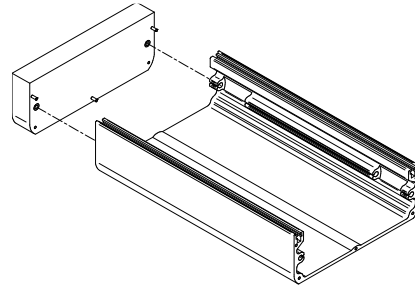

- (b) Fix the wooden side to the case with two M4x14 screws (E.2) placed through the mounting brackets (A.2 or B.2). Use the L-Shaped 2.5mm Hex Key (F.3).

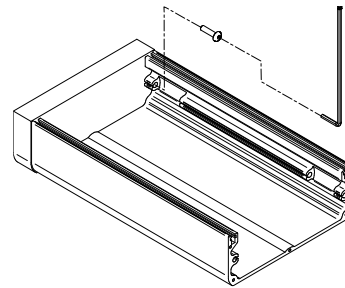

- (c) Once the side is tight, place the required M3 square nuts (E.3) in the PLUS' rails.

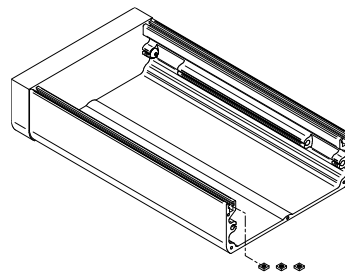

- (d) Repeat points (a) and (b) for the second wooden side.
- (e) Stick the four rubber feet under the case.

5.2 SINGLE UNIT TO ALUMINUM SIDES

- (a) Connect the first aluminum side (C) to the PLUS unit by inserting its two threaded fasteners to the case's mounting brackets.

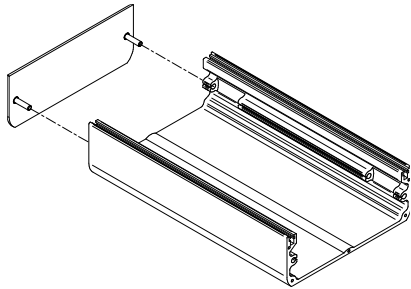

- (b) Insert the teathed washers on the sides' threaded fasteners and fix them to the case's mounting brackets with two teathed washers (E.4) and M4 Hex nuts (E.5) using the custom thin wrench (F.2).

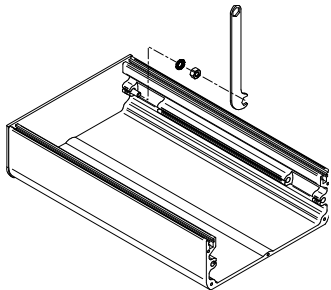

- (c) Once the side is tight, place the required M3 square nuts in the PLUS' rails.

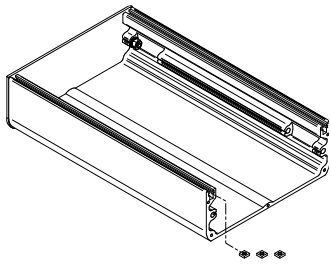

- (d) Repeat points (a) and (b) for the second aluminum side.
- (e) Stick the four rubber feet under the case.

5.3 SINGLE UNIT TO SINGLE UNIT

- (a) Insert three M2 dowel pins to the holes on the side of the first unit, as displayed by the figure.

- (b) Connect the first unit to the second unit by matching the dowels with the holes.
- (c) Insert two M4x25 screws trough the mounting brackets of both units.
- (d) Place a teathed washer at the end of each M4x25 screw.
- (e) Place a M4 Hex nut after each teathed washer.
- (f) Use the custom thin or thick wrench to hold the Hex nuts in place while fastening the M4 screws with the L-shaped Hex key.
- (g) Once the side is tight, place the 24 square nuts in the PLUS' rails: 12 at the top, 12 at the bottom.
- (h) Stick the four rubber feet under the case.
- (i) To mount the sides, refer to §§5.1–5.2.

5.4 SINGLE WINDOWED UNIT TO SINGLE WINDOWED UNIT (ROW EXTENSION)

- (a) Place the two windowed unit with the two windows facing each other and with the thin felt strip between them.
- (b) Connect the two units by inserting four M4x14 screws (E.2) through the holes beside the windows.
- (c) Place a teathed washer (E.4) at the end of each M4x14 screw.
- (d) Place a M4 Hex nut (E.5) after each teathed washer.

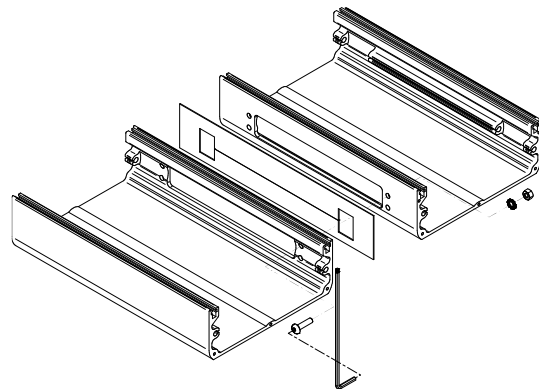

- (e) Use the thick wrench (F.1) to hold the Hex nuts in place while fastening the M4 screws with the L-shaped Hex key (F.3).
- (f) Stick the four rubber feet under the case.
- (g) To mount the sides, refer to §§5.1–5.2.

WHAT'S IN THE BOX

Code	Description	Q.ty	Detail
F-CAN0-MX	CGM Creative Mixer – Channel	1	Channel Module
		1	16 to 10 poles IDC Power Cable
		2	M3x6 black and zinc with plastic washer for mounting
F-CAN3-MX	CGM Creative Mixer – Stereo Channel	1	Stereo Channel Module
		1	16 to 10 poles IDC Power Cable
		2	M3x6 black and zinc with plastic washer for mounting
F-CAN1-MX	CGM Creative Mixer – Quad Stereo Channel	1	Quad Stereo Channel Module
		1	16 to 10 poles IDC Power Cable
		4	M3x6 black and zinc with plastic washer for mounting
		1	Group Module
F-GRU0-MX	CGM Creative Mixer – Group (2016)	2	M3x6 black and zinc with plastic washer for mounting
		2	10 poles IDC Link Cable – 1 Group to 4 Channels
		1	Group Module
F-GRU1-MX	CGM Creative Mixer – Group	2	M3x6 black and zinc with plastic washer for mounting
		1	10 poles IDC Link System – 1 Group to 2 Channel Modules (2-cable set)
		1	Master Module
F-MAS0-MX	CGM Creative Mixer – Master	1	16 to 10 poles IDC Power Cable
		2	M3x6 black and zinc with plastic washer for mounting
		1	10 poles IDC Link Cable – 1 Master to 1 Group
F-MAS1-MX	CGM Creative Mixer – Masterone	1	Masterone Module
		1	16 to 10 poles IDC Power Cable
		4	M3x6 black and zinc with plastic washer for mounting
		1	10 poles IDC Link Cable – 1 Master to 1 Group - Extendable
F-INS0-MX	CGM Creative Mixer – Insert	1	Insert Module
		1	16 to 10 poles IDC Power Cable
		2	M3x6 black and zinc with plastic washer for mounting
F-SAP0-RG	SAPÈL	2	10 poles IDC Link Cable – to Channel or Group
		1	SAPÈL Module
		1	16 to 10 poles IDC Power Cable
F-FUM0-SP	FUMANA	4	M3x6 black and zinc with plastic washer for mounting
		1	FUMANA Module
		1	16 to 10 poles IDC Power Cable
F-FAL0-DE	FALISTRÌ	4	M3x6 black and zinc with plastic washer for mounting
		1	FALISTRÌ Module
		1	16 to 10 poles IDC Power Cable
F-UST0-SQ	USTA	1	USTA Module
		1	16 to 10 poles IDC Power Cable
		1	microSD card
		1	microSD to SD adapter
F-BRE0-OS	BRENSO	4	M3x6 black and zinc with plastic washer for mounting
		1	BRENSO module
		1	16 to 10 poles IDC Power Cable
F-CUN0-FL	CUNSA	4	M3x6 black and zinc with plastic washer for mounting
		1	CUNSA module
		1	16 to 10 poles IDC Power Cable
F-CUN0-FL	BAGÀI	4	M3x6 black and zinc with plastic washer for mounting
		1	BAGÀI module
		1	16 to 10 poles IDC Power Cable

		4	M3x6 black and zinc with plastic washer for mounting
		1	333 Module
F-3330-SM	333	1	16 to 10 poles IDC Power Cable
		2	M3x6 black and zinc with plastic washer for mounting
		1	321 Module
F-3210-TA	321	1	16 to 10 poles IDC Power Cable
		2	M3x6 black and zinc with plastic washer for mounting
		1	411 Module
F-3210-TA	411	1	16 to 10 poles IDC Power Cable
		2	M3x6 black and zinc with plastic washer for mounting
F-C120-LK	CGM Link Cable - 1 Master to 2 Groups	1	10 poles IDC Link Cable - 1 Master to 2 Groups
F-C130-LK	CGM Link Cable - 1 Master to 3 Groups	1	10 poles IDC Link Cable - 1 Master to 3 Groups
F-C140-LK	CGM Link Cable - 1 Master to 4 Groups	1	10 poles IDC Link Cable - 1 Master to 4 Groups
F-C011-LK	CGM Link Cable - 1 Group to 1 Channel	2	10 poles IDC Link Cable - 1 Group to 1 Channel [NOW DISCONTINUED]
F-C012-LK	CGM Link Cable - 1 Group to 2 Channels	2	10 poles IDC Link Cable - 1 Group to 2 Channels [NOW DISCONTINUED]
F-C013-LK	CGM Link Cable - 1 Group to 3 Channels	2	10 poles IDC Link Cable - 1 Group to 3 Channels [NOW DISCONTINUED]
F-C015-LK	CGM Link Cable - 1 Group to 5 Channels	2	10 poles IDC Link Cable - 1 Group to 5 Channels [NOW DISCONTINUED]
F-C016-LK	CGM Link Cable - 1 Group to 6 Channels	2	10 poles IDC Link Cable - 1 Group to 6 Channels [NOW DISCONTINUED]
F-C017-LK	CGM Link Cable - 1 Group to 7 Channels	2	10 poles IDC Link Cable - 1 Group to 7 Channels [NOW DISCONTINUED]
F-C018-LK	CGM Link Cable - 1 Group to 8 Channels	2	10 poles IDC Link Cable - 1 Group to 8 Channels [NOW DISCONTINUED]
F-G1C2-LS	CGM Link System - 1 Group to 2 Channel Modules	2	10 poles IDC Link Cable - 1 Group to 2 Channel Modules (C/SC/QSC)
F-G1C4-LS	CGM Link System - 1 Group to 4 Channel Modules	2	10 poles IDC Link Cable - 1 Group to 4 Channel Modules (C/SC/QSC)
F-G1C8-LS	CGM Link System - 1 Group to 8 Channel Modules	2	10 poles IDC Link Cable - 1 Group to 8 Channel Modules (C or QSC)
F-G2GX-LS	CGM Link System - Group to Group Extension	1	10 Poles IDC Link Cable - Group to Group Extension
		1	PLUS closed unit
		4	Rubber Feet
		3	Dowel Pin M2x8 3
F-PL00-AB	PLUS Unit 1 pc	2	Teethed Washer M4
		2	Hex Nut M4
		2	Screw M4x25
		12	Square Nuts M3
		2	PLUS windowed unit
		1	Thin felt strip
		8	Rubber Feet
		6	Dowel Pin M2x8
F-PL05-AB	PLUS Row Extension 2 pcs	8	Teethed Washer M4
		8	Hex Nut M4
		4	Screw M4x14
		4	Screw M4x25
		24	Square Nuts M3
		4	PLUS windowed unit
		2	Thin felt strip
		16	Rubber Feet
		6	Dowel Pin M2x8
F-PL01-AB	PLUS Row Extension 4 pcs	12	Teethed Washer M4
		12	Hex Nut M4
		8	Screw M4x14
		4	Screw M4x25
		50	Square Nuts M3
		2	Wood Side
F-PL02-D2	PLUS Wood Sides Dark Combo Pack 2 pcs		
F-PL02-P2	PLUS Wood Sides Spotted Combo Pack 2 pcs	6	Dowel Pin M2x8
F-PL02-L2	PLUS Wood Sides Light Combo Pack 2 pcs	4	Screw M4x14 4

		1	Hex Key 2.5 mm L shaped with long arm
		1	Thick Wrench for M4 nuts
		2	Thin Side
F-PL02-Y2	PLUS Thin Sides Yellow Combo Pack 2 pcs	2	Hex Nut M4
F-PL02-G2	PLUS Thin Sides Green Combo Pack 2 pcs	2	Teethed Washer M4
F-PL02-B2	PLUS Thin Sides Black Combo Pack 2 pcs	1	Hex Key 2.5 mm L shaped with long arm
		1	Thin Wrench for M4 nuts

LIST OF REVISIONS

Revision	Date	Description
1	May 2019	USTA preliminary content Added Revision section SAPÈL, FALISTRÌ reorganized hierarchy Added Techniques section
2	Sep 2019	Updated Techniques section Improved FUMANA section Improved SAPÈL section SAPÈL, 321, 333 replaced flow chart Added Interfaces section USTA official content
3	Apr 2020	Updated Techniques section BRENSO preliminary content USTA updated to fw 152
4	Jun 2020	BRENSO official content Included in-text hyperlinks to Frap Tools' Techniques Updated layout and formatting Added indexed labelled interfaces at the beginning of every chapter to improve the readability Improved cross-references
5	Jun 2020	Fixed wrong labelling on BRENSO
6	Nov 2020	Quad Stereo Channel added to CGM section Added Revisions for Falistri and Brenso Added the section Modular Synthesis: Core Concepts Added the section Suggested Readings Improved SAPÈL's Philosophy and Design paragraph Revised the Specifications section and moved at the end of the individual module's chapters Corrected various typos Fixed wrong labelling on FALISTRÌ Improved cross-references
7	Jul 2021	Added Masterone to the CGM chapter Added the Plus chapter Added the paragraph about rms to the Core Concepts chapter Added the Audio Levels section to the Core Concepts chapter Restored the Analog Trimming procedure for the USTA sequencer Corrected various typos
8	Nov 2021	Added the Stereo Channel section to the CGM chapter Rearranged and formatted the CGM chapter Corrected some typos in the CGM Tech Specs Added sections on AM/RM and FM to the Modular Synthesis: Core Concept chapter Removed the AM/RM section from FALISTRÌ's chapter Removed the FM section from BRENSO's chapter Added new Techniques hyperlinks Fixed a broken TOC and made it clickable again Corrected various typos
9	May 2022	Added the sections about Fine BPM and Voltage-Controlled Pattern Recall to the USTA chapter Added the release notes for firmware 155 to the USTA chapter Added the suggested warmup time to each module's tech specs Rearranged the Technical Data section of each chapter Added a sentence to the Voltage Sampling section of SAPÈL's chapter Added a paragraph to the Quantized Random Voltages section of SAPÈL's chapter Corrected the box content of the new G module Added new Techniques hyperlinks
10	July 2023	Clarified the behavior of the Clone Track function in the USTA chapter Revised the FUMANA chapter

Revised the FALISTRI chapter
Corrected typos in the Modular Synthesis: Core Concept chapter
Added CUNSA chapter
General spelling revision
Added CV input ranges to the Tech Specs section of each module
Added sections to the Core Concept chapter (V/oct, Filters, Temperature)

11	April 2024	Added the Insert section to the CGM chapter Corrected various typos and formatting errors
12	May 2024	Added the Core Concept section 1.1 on sampling Added the Bagàì chapter Added the 4.1.1 chapter
